

ROOF TRUSS ELEVATION A-A  
1/4"=1'-0"

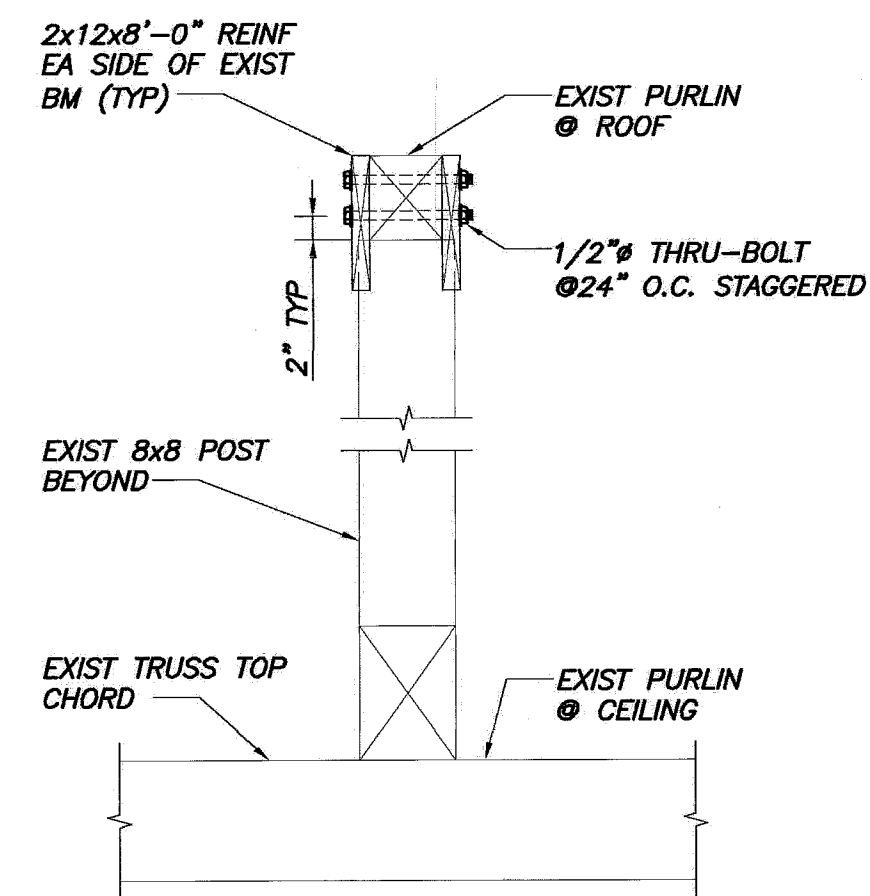

SECTION 1  
3/4"=1'-0" S2.3

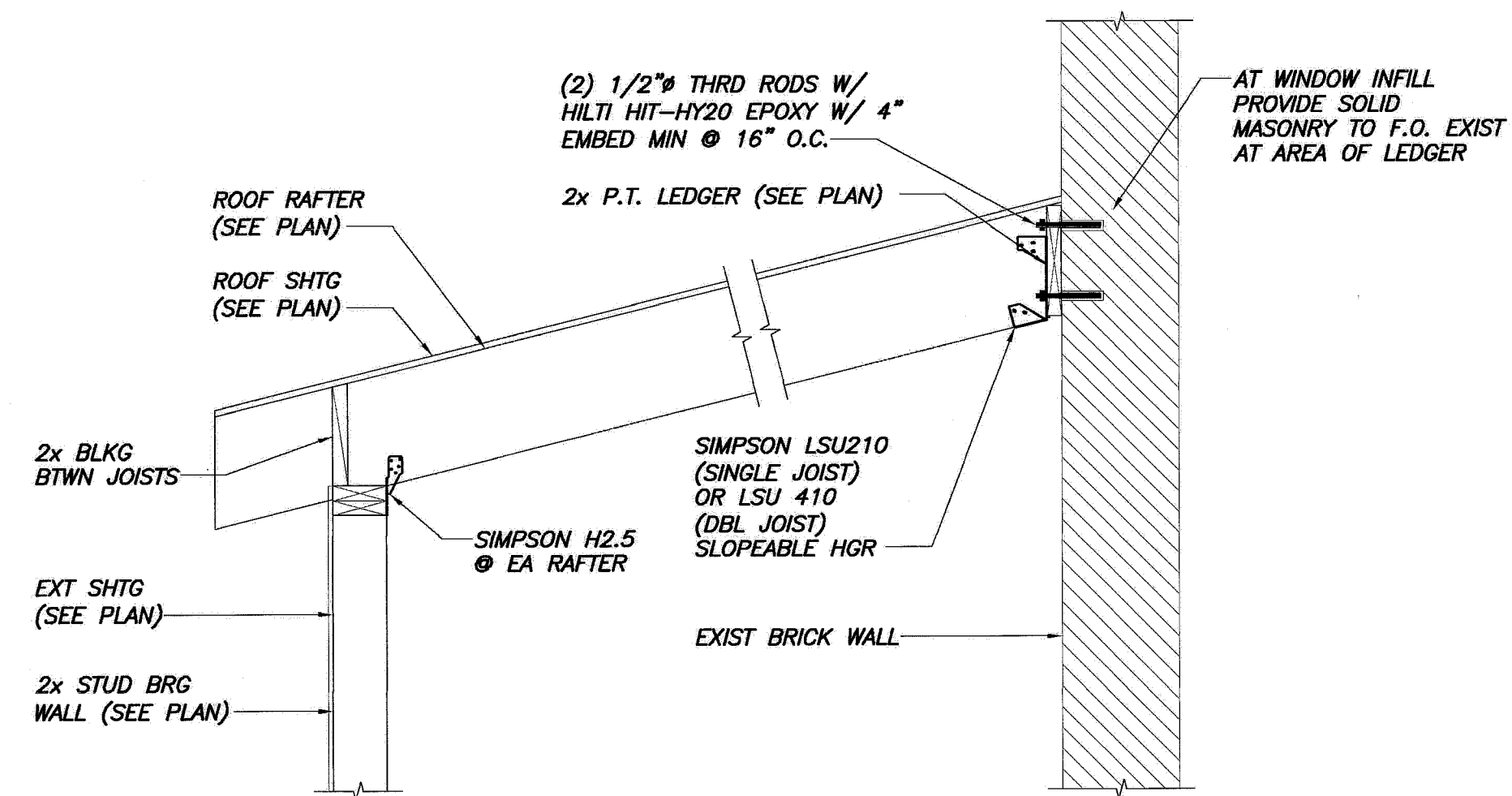

SECTION 2  
3/4"=1'-0" S1.3

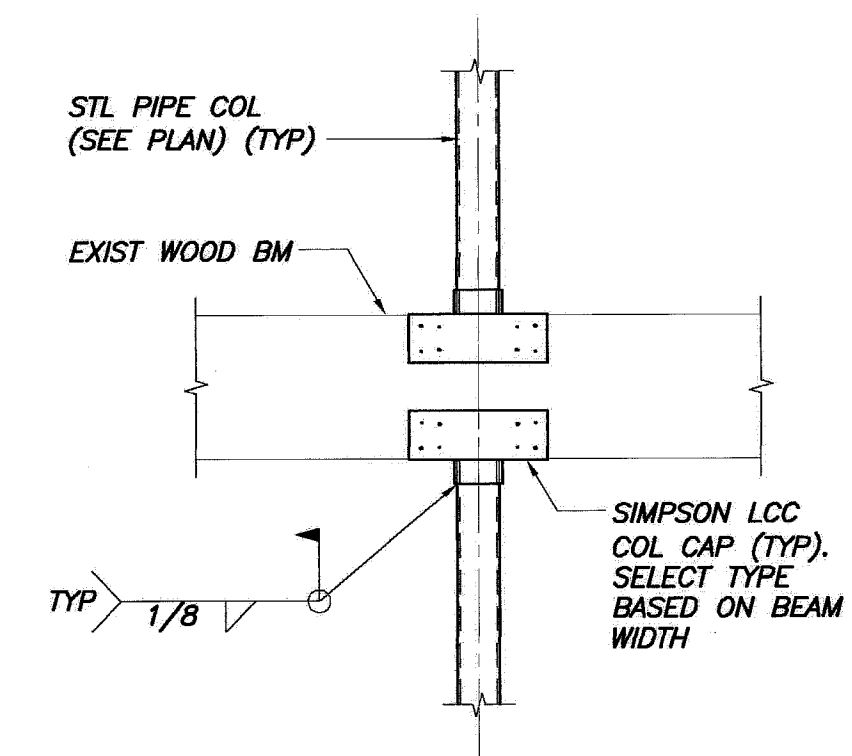

SECTION 3  
3/4"=1'-0" S1.3

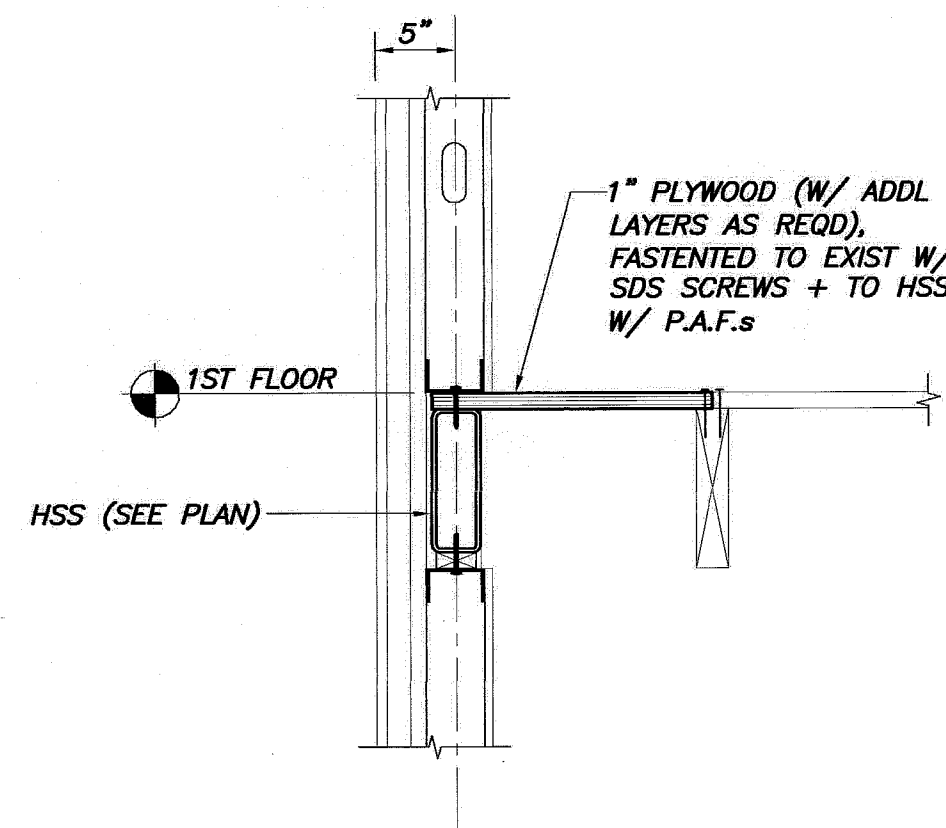

SECTION 4  
1"=1'-0" S1.2

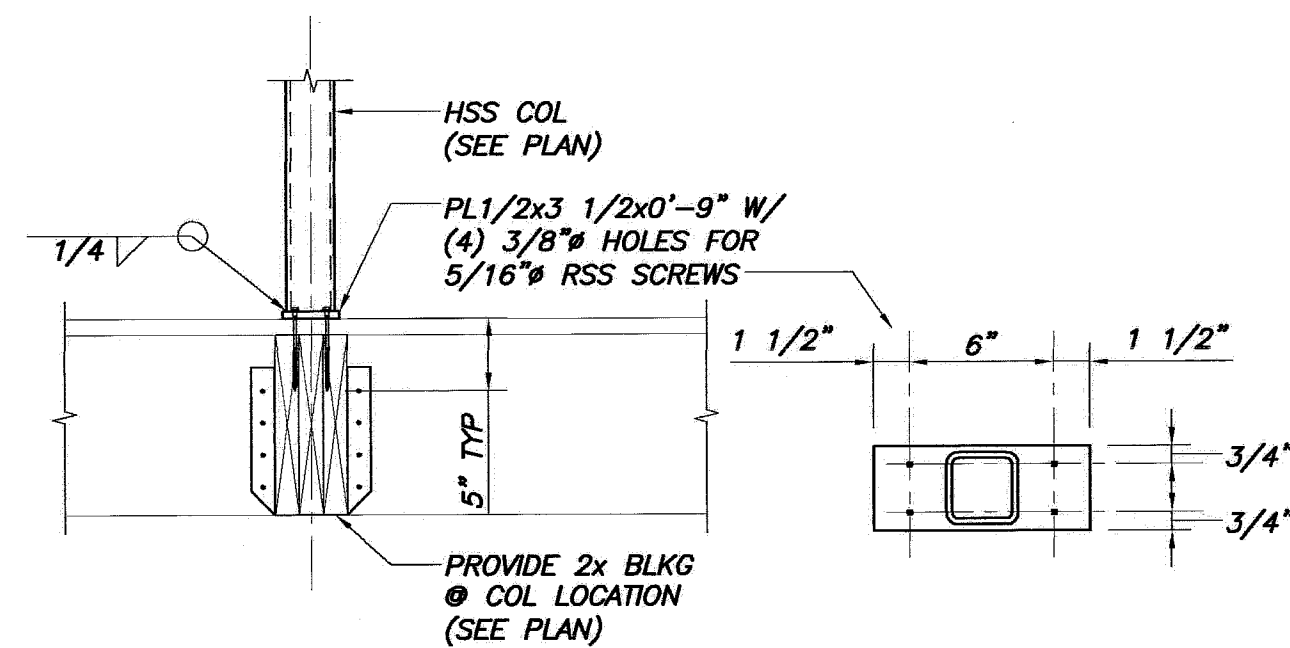

SECTION 5  
1"=1'-0" S1.2

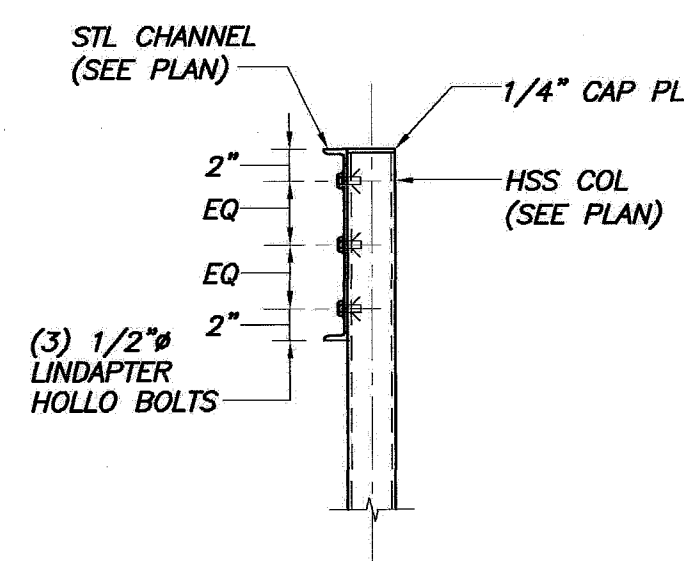

SECTION 6  
1"=1'-0" S1.2

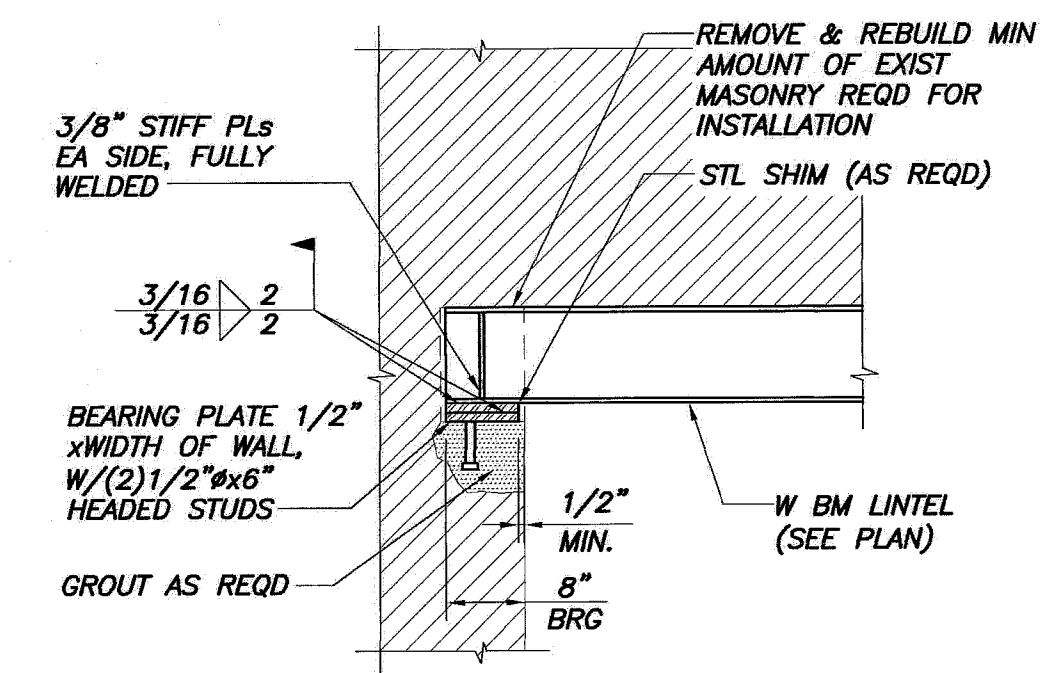

TYP BEAM POCKET DETAIL U.N.O.  
N.T.S.



CWS Architects

Architecture  
Space Planning  
Value Design

434 Cumberland Avenue  
Portland, ME 04101  
Phone: (207) 774-4441  
Fax: (207) 774-4016

www.CWSArch.com

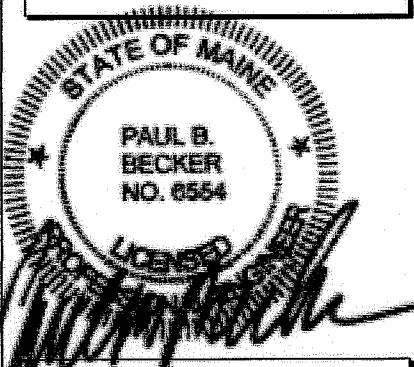

Owner:

**Avesta Munjoy Commons, LP.**

307 Cumberland Ave.  
Portland, Maine 04101  
TEL. 207-553-7180

Client:

**Munjoy Commons Apartments**

Portland, Maine

**BECKER**  
structural engineers, inc.

75 York Street  
Portland, ME 04101-4761  
Tel: 207-879-1888  
Fax: 207-879-1822  
www.beckerinc.com

Project No: 07429

Drawing Title:

**SHAILER SECTIONS & DETAILS**

Scale: AS NOTED

Date: AUGUST 28, 2009

Revisions:

- △
- △
- △
- △
- △
- △

Drawing Number:

**SHAILER S2.3**