

HIGH FORWARD REACH LIMIT
NTS

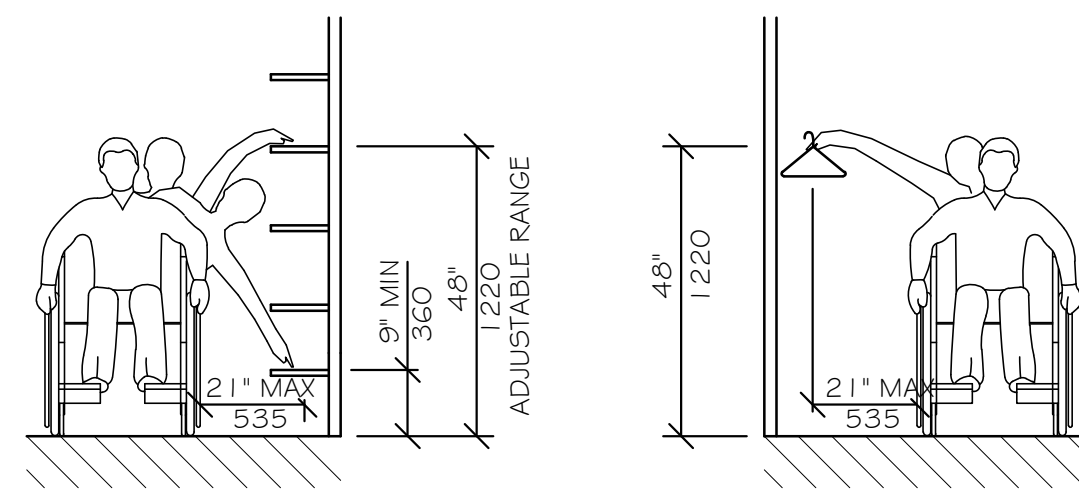

SHELVES
CLOSETS
STORAGE SHELVES AND CLOSETS
NTS

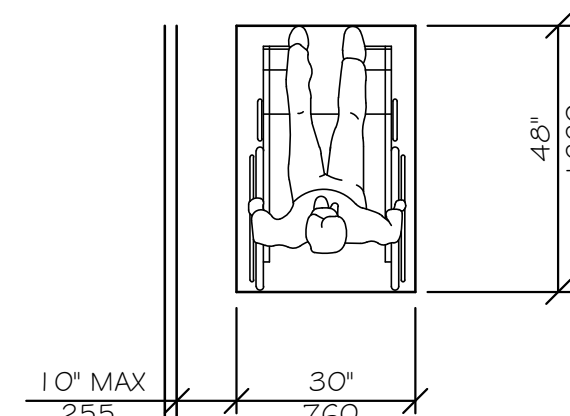

CLEAR FLOOR SPACE
PARALLEL APPROACH
NTS

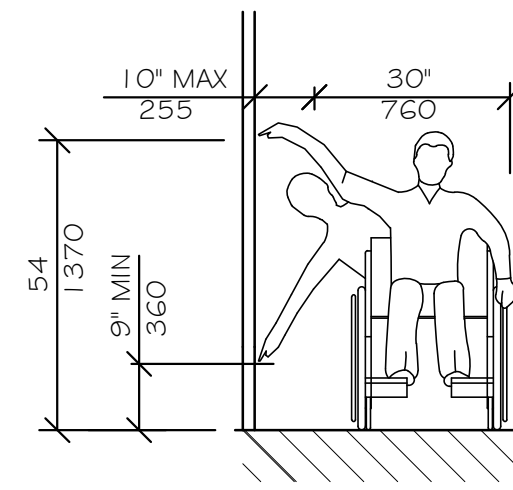

HIGH AND LOW
SIDE REACH LIMITS
NTS

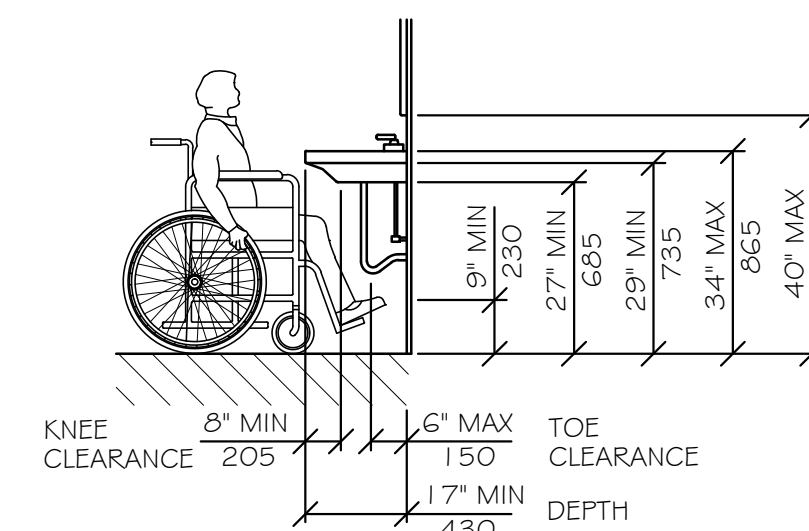

LAVATORY CLEARANCES
NTS

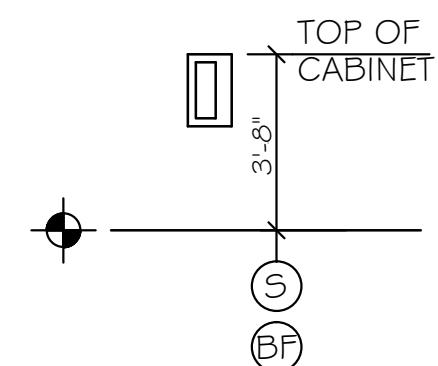

FIRE EXTINGUISHER
CABINET (FEC)
NTS

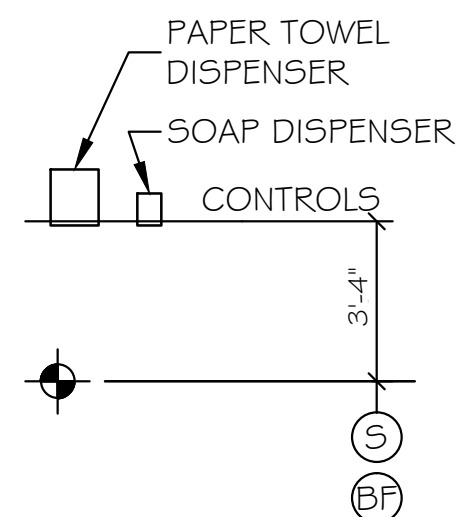

TOWEL & SOAP DISPENSERS
NTS

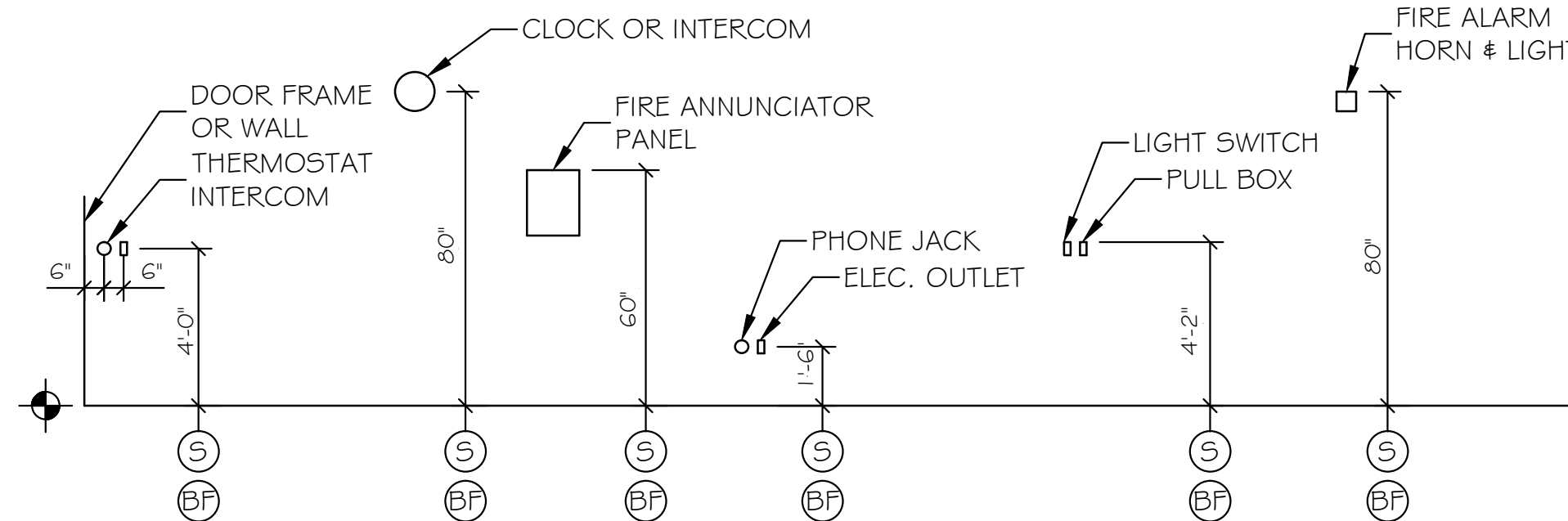

ELECTRICAL & FIRE PROTECTION DEVICES
TYPICAL UNLESS NOTED OTHERWISE
NTS

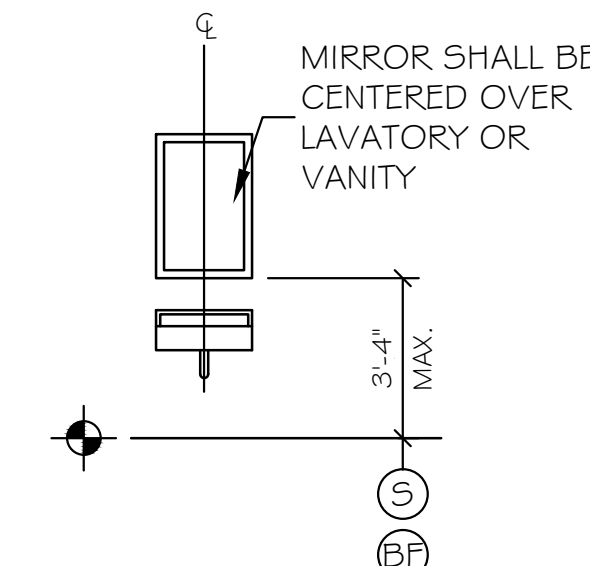

MIRROR OR MEDICINE CABINET
NTS

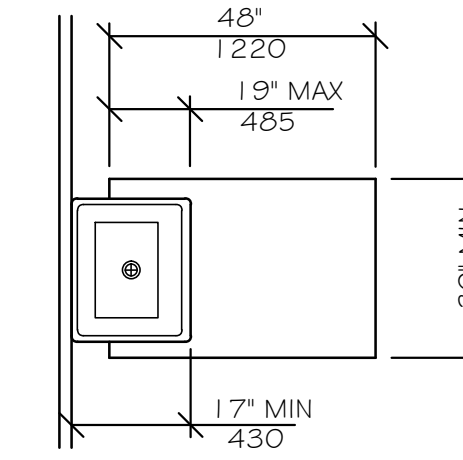

CLEAR FLOOR SPACE
AT LAVATORIES
NTS

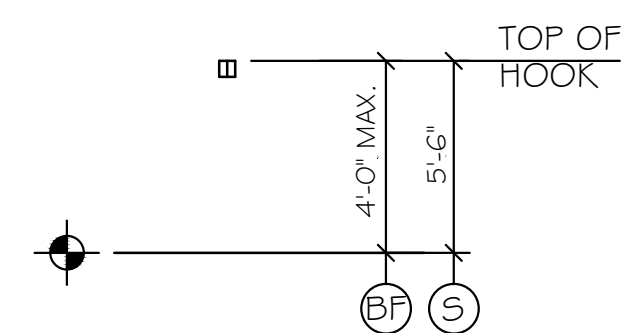

CLOTHES HOOK
NTS

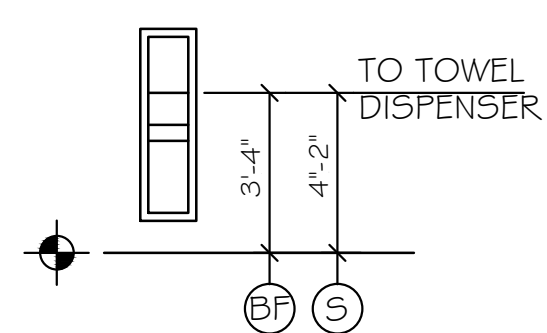

TOWEL DISPENSER
DISPOSAL UNIT
NTS

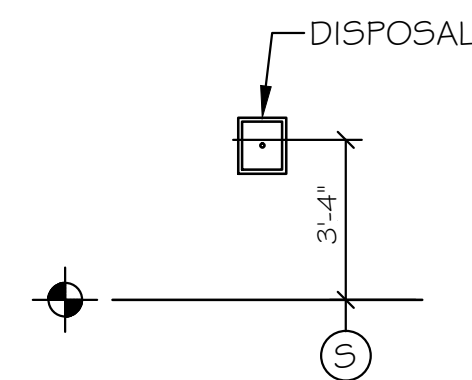

SANITARY
DISPOSAL UNIT
NTS

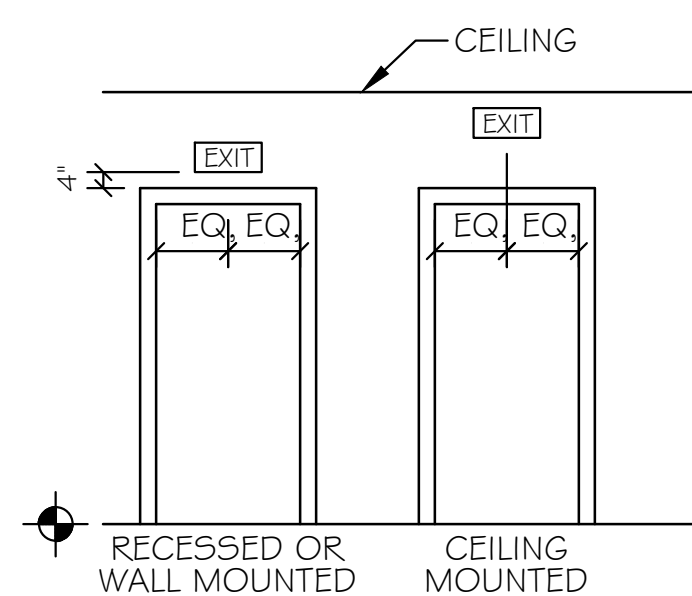

EXIT SIGNS
(TYPICAL UNLESS OTHERWISE NOTED)
NTS

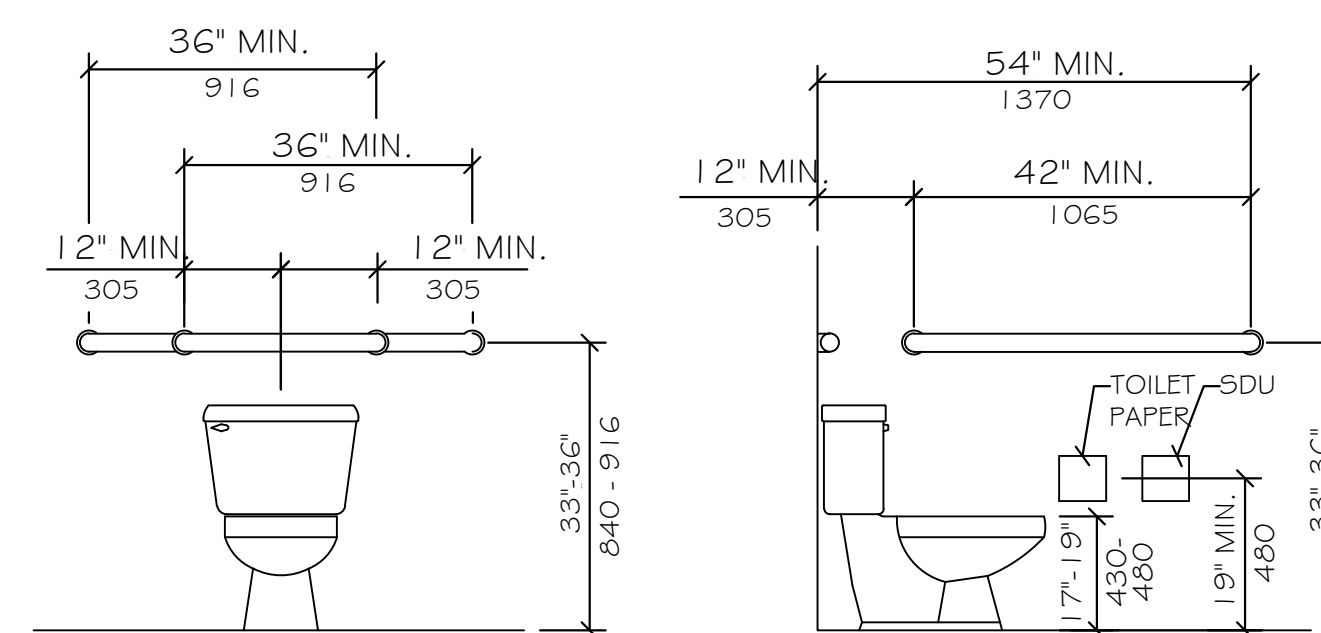

GRAB BARS AT WATER CLOSETS
NTS

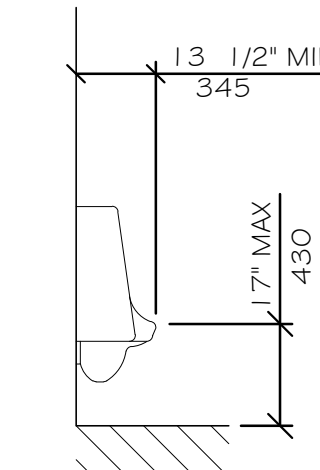

HEIGHT AND DEPTH OF URINAL
NTS

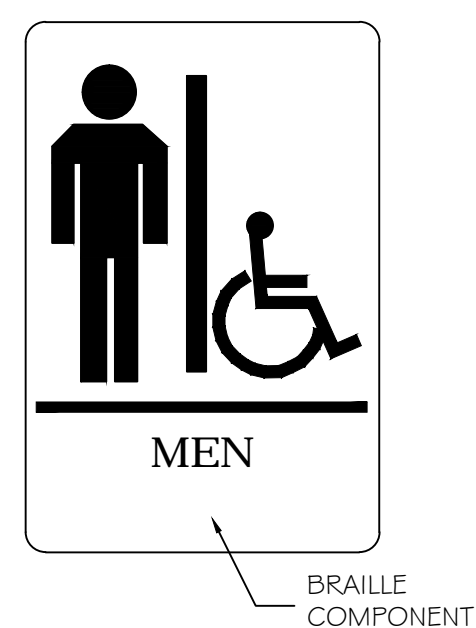

SIGN A



SIGN B



SIGN C

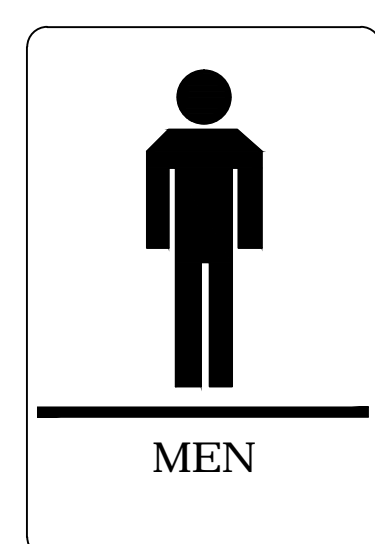

SIGN D

LEGEND

- Ⓢ STANDARD MOUNTING HEIGHT
- Ⓟ BARRIER FREE ADULT MOUNTING HEIGHT
- Ⓢ FINISH FLOOR LINE

NOTE

MOUNT ALL FIXTURES AT STANDARD MOUNTING HEIGHT UNLESS INDICATED ON PLAN BY A Ⓢ SYMBOL. A Ⓟ SYMBOL AT ANY ROOM SHALL INCLUDE ONE OF ANY FIXTURE AND ACCESSORY WITHIN THE ROOM.

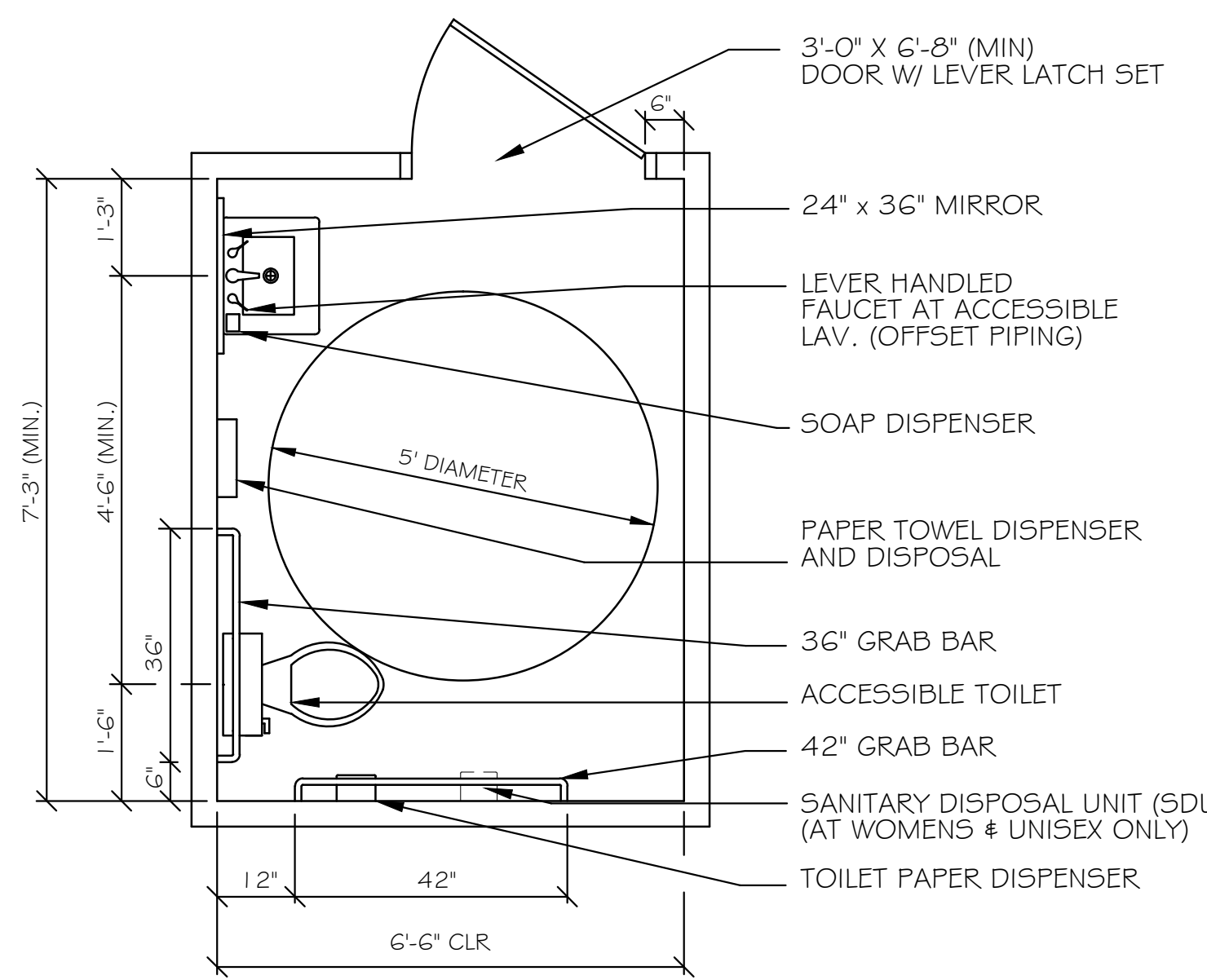

TYPICAL ACCESSORIES
NTS

ACCESSIBILITY ACCESSORY MOUNTING HEIGHTS

GRAB BARS	33"-36"
TOILET PAPER HOLDER	19" MIN
TOWEL BAR/PAPER TOWEL DISPENSER	48" MAX
BUILT-IN PAPER TOWEL DISPENSER	48" MAX
SOAP DISH/DISPENSER AT WALL	48" MAX
SANITARY DISPOSAL UNIT	19" MAX
MIRROR (BOTTOM)	40" MAX
SHELVES/STORAGE	48" MAX
ELECTRICAL SWITCHES/OUTLETS	48" MAX
COAT HOOKS/RODS	48" MAX
SIGNAGE (TO BRAILLE COMPONENT)	60" MAX

ACCESSIBILITY GENERAL NOTES

1. DOORWAYS SHALL HAVE A MINIMUM CLEAR WIDTH OF 32" WITH THE DOOR OPEN 90 DEGREES. MEASURED BETWEEN THE FACE OF THE DOOR AND THE OPPOSITE STOP.
2. ALL DOORS SHALL HAVE LEVER HANDLE HARDWARE, EXCEPT AT SECURED STORAGE ROOMS, MECHANICAL ROOMS, AND ELEVATOR MACHINE ROOMS.
3. ALL CLOSERS SHALL BE 5LB PULL MAXIMUM AT DOORS EQUIPPED WITH LEVER HANDLE HARDWARE.
4. ALL DOORS WITH CLOSERS SHALL HAVE 18" CLEAR DISTANCE FROM THE LATCHSIDE OF THE OPENING TO ANY ADJACENT WALL OR OBSTRUCTION ON THE PULL SIDE OF THE OPENING.
5. ALL DOORS WITH CLOSERS SHALL HAVE 12" CLEAR DISTANCE FROM THE LATCHSIDE OF THE OPENING TO ANY ADJACENT WALL OR OBSTRUCTION ON THE PUSH SIDE OF THE OPENING.
6. ALL SIGNAGE SHALL BE MOUNTED 60" AFF TO BRAILLE COMPONENT AT LATCH-SIDE WALL OF DOORS AND OPENINGS.
7. COMPLY WITH 2010 EDITION OF THE AMERICANS WITH DISABILITIES ACT.