

DISPLAY THIS CARD ON PRINCIPAL FRONTAGE OF WORK

# CITY OF PORTLAND

BUILDING DEPARTMENT

## PERMIT

Please Read Application And Notes, If Any, Attached

**PERMIT ISSUED**

Permit Number: 071111  
SEP 26 2007

**CITY OF PORTLAND**

This is to certify that A & M PARTNERS LLC / N..., Inc.

has permission to Install a Fire Alarm System

AT 59 WASHINGTON AVE 013 1043001

provided that the person or persons, firm or corporation accepting this permit shall comply with all of the provisions of the Statutes of Maine and of the Ordinances of the City of Portland regulating the construction, maintenance and use of buildings and structures, and of the application on file in this department.

Apply to Public Works for street line and grade if nature of work requires such information.

Notification of inspection must be given and when permission is procured before this building or part thereof is altered or closed-in. **24 HOUR NOTICE IS REQUIRED.**

A certificate of occupancy must be procured by owner before this building or part thereof is occupied.

**OTHER REQUIRED APPROVALS**

Fire Dept. \_\_\_\_\_

Health Dept. \_\_\_\_\_

Appeal Board \_\_\_\_\_

Other \_\_\_\_\_  
Department Name

*Jeanne Benke* 9/26/07  
Director - Building & Inspection Services

**PENALTY FOR REMOVING THIS CARD**

# City of Portland, Maine - Building or Use Permit Application

389 Congress Street, 04101 Tel: (207) 874-8703, Fax: (207) 874-8716

Permit No: 07-1111	Issue Date: 07/12/2007	CBL: 013 I043001
-----------------------	---------------------------	---------------------

Location of Construction: 59 WASHINGTON AVE	Owner Name: A & M PARTNERS LLC	Owner Address: 120 EXCHANGE ST	Phone:
Business Name:	Contractor Name: Norris, Inc.	Contractor Address: 2257 W Broadway South Portland	Phone 2078833473
Lessee/Buyer's Name	Phone:	Permit Type: Fire Alarm System	Zone: B-A

Past Use: Commercial	Proposed Use: Commercial Install a Fire Alarm System	Permit Fee: \$80.00	Cost of Work: \$5,820.00	CEO District: 1
		FIRE DEPT: <input checked="" type="checkbox"/> Approved <input type="checkbox"/> Denied 10 W FPA 72	INSPECTION: Use Group: B Type: Fire Alarm IBC-2003	

Proposed Project Description: Install a Fire Alarm System	Signature: <i>Greg Cruz</i>	Signature: <i>JMB 9/26/07</i>
PEDESTRIAN ACTIVITIES DISTRICT (P.A.D.)		
Action: <input type="checkbox"/> Approved <input type="checkbox"/> Approved w/Conditions <input type="checkbox"/> Denied		
Signature:		Date:

Permit Taken By: dmartin	Date Applied For: 09/07/2007	<b>Zoning Approval</b>
-----------------------------	---------------------------------	------------------------

- This permit application does not preclude the Applicant(s) from meeting applicable State and Federal Rules.
- Building permits do not include plumbing, septic or electrical work.
- Building permits are void if work is not started within six (6) months of the date of issuance. False information may invalidate a building permit and stop all work..

<b>Special Zone or Reviews</b> <input type="checkbox"/> Shoreland <input type="checkbox"/> Wetland <input type="checkbox"/> Flood Zone <input type="checkbox"/> Subdivision <input type="checkbox"/> Site Plan Maj <input type="checkbox"/> Minor <input type="checkbox"/> MM <input type="checkbox"/> Date: <i>OK 9/12/07</i>	<b>Zoning Appeal</b> <input type="checkbox"/> Variance <input type="checkbox"/> Miscellaneous <input type="checkbox"/> Conditional Use <input type="checkbox"/> Interpretation <input type="checkbox"/> Approved <input type="checkbox"/> Denied Date:	<b>Historic Preservation</b> <input checked="" type="checkbox"/> Not in District or Landmark <input type="checkbox"/> Does Not Require Review <input type="checkbox"/> Requires Review <input type="checkbox"/> Approved <input type="checkbox"/> Approved w/Conditions <input type="checkbox"/> Denied Date: <i>S</i>
---	---	---

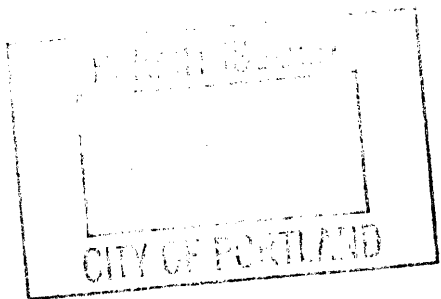

## CERTIFICATION

I hereby certify that I am the owner of record of the named property, or that the proposed work is authorized by the owner of record and that I have been authorized by the owner to make this application as his authorized agent and I agree to conform to all applicable laws of this jurisdiction. In addition, if a permit for work described in the application is issued, I certify that the code official's authorized representative shall have the authority to enter all areas covered by such permit at any reasonable hour to enforce the provision of the code(s) applicable to such permit.

SIGNATURE OF APPLICANT	ADDRESS	DATE	PHONE
RESPONSIBLE PERSON IN CHARGE OF WORK, TITLE		DATE	PHONE

**City of Portland, Maine - Building or Use Permit**

389 Congress Street, 04101 Tel: (207) 874-8703, Fax: (207) 874-8716

<b>Permit No:</b> 07-1111	<b>Date Applied For:</b> 09/07/2007	<b>CBL:</b> 013 I043001
------------------------------	--	----------------------------

<b>Location of Construction:</b> 59 WASHINGTON AVE	<b>Owner Name:</b> A & M PARTNERS LLC	<b>Owner Address:</b> 120 EXCHANGE ST	<b>Phone:</b>
<b>Business Name:</b>	<b>Contractor Name:</b> Norris, Inc.	<b>Contractor Address:</b> 2257 W Broadway South Portland	<b>Phone:</b> (207) 883-3473
<b>Lessee/Buyer's Name</b>	<b>Phone:</b>	<b>Permit Type:</b> Fire Alarm System	

<b>Proposed Use:</b> Commercial Install a Fire Alarm System	<b>Proposed Project Description:</b> Install a Fire Alarm System
--	---

<b>Dept:</b> Zoning	<b>Status:</b> Approved	<b>Reviewer:</b> Marge Schmuckal	<b>Approval Date:</b> 09/12/2007	<b>Ok to Issue:</b> <input checked="" type="checkbox"/>
<b>Note:</b>				
<b>Dept:</b> Building	<b>Status:</b> Approved with Conditions	<b>Reviewer:</b> Jeanine Bourke	<b>Approval Date:</b> 09/26/2007	<b>Ok to Issue:</b> <input checked="" type="checkbox"/>
<b>Note:</b>				
1) Fire Alarm systems shall be installed per Sec. 907 of the IBC 2003				
<b>Dept:</b> Fire	<b>Status:</b> Approved with Conditions	<b>Reviewer:</b> Capt Greg Cass	<b>Approval Date:</b> 09/18/2007	<b>Ok to Issue:</b> <input checked="" type="checkbox"/>
<b>Note:</b>				
1) The fire alarm system shall comply with NFPA 72				
2) Installation of a Fire Alarm system requires a Knox Box to be installed per city ordinance				

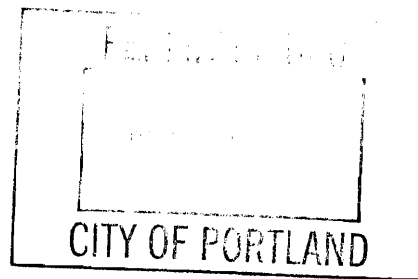



# General Building Permit Application

If you or the property owner owes real estate or personal property taxes or user charges on any property within the City, payment arrangements must be made before permits of any kind are accepted.

Location/Address of Construction: <u>75 Washington Ave</u>		
Total Square Footage of Proposed Structure/Area		Square Footage of Lot
Tax Assessor's Chart, Block & Lot Chart#      Block#      Lot#	Applicant * <u>must be owner, Lessee or Buyer</u> * Name <u>A&amp;M Partners</u> Address <u>120 Exchange St.</u> City, State & Zip <u>Portland Me 04101</u>	Telephone: <u>879-1358</u>
* <u>13</u> <u>I</u> <u>043</u>		
Lessee/DBA (If Applicable)	Owner (if different from Applicant) Name <u>A&amp;M Partners</u> Address <u>120 Exchange St.</u> City, State & Zip <u>Portland Me 04101</u>	Cost Of Work: \$ <u>5820.00</u> C of O Fee: \$ <u>N/A</u> Total Fee: \$ <u>80</u>
Current legal use (i.e. single family) <u>Commercial property</u> If vacant, what was the previous use? _____ Proposed Specific use: _____ Is property part of a subdivision? _____ If yes, please name _____ Project description: <u>Fire Alarm System</u>		
Contractor's name: <u>Norris Inc</u>		
Address: <u>2257 W. Broadway</u>		
City, State & Zip <u>South Portland Me 04106</u>		Telephone: <u>883-3473</u>
Who should we contact when the permit is ready: <u>Dana Champagne</u>		Telephone: <u>883-3473</u>
Mailing address: <u>2257 W. Broadway South Portland Me 04106</u>		

**Please submit all of the information outlined on the applicable Checklist. Failure to do so will result in the automatic denial of your permit.**

In order to be sure the City fully understands the full scope of the project, the Planning and Development Department may request additional information prior to the issuance of a permit. For further information or to download copies of this form and other applications visit the Inspections Division on-line at [www.portlandmaine.gov](http://www.portlandmaine.gov), or stop by the Inspections Division office, room 315 City Hall or call 874-8703.

I hereby certify that I am the Owner of record of the named property, or that the owner of record authorizes the proposed work and that I have been authorized by the owner to make this application as his/her authorized agent. I agree to conform to all applicable laws of this jurisdiction. In addition, if a permit for work described in this application is issued, I certify that the Code Official's authorized representative shall have the authority to enter all areas covered by this permit at any reasonable hour to enforce the provisions of the codes applicable to this permit.

Signature: <u>[Signature]</u>	Date: <u>9-7-07</u>
-------------------------------	---------------------

**This is not a permit; you may not commence ANY work until the permit is issue**

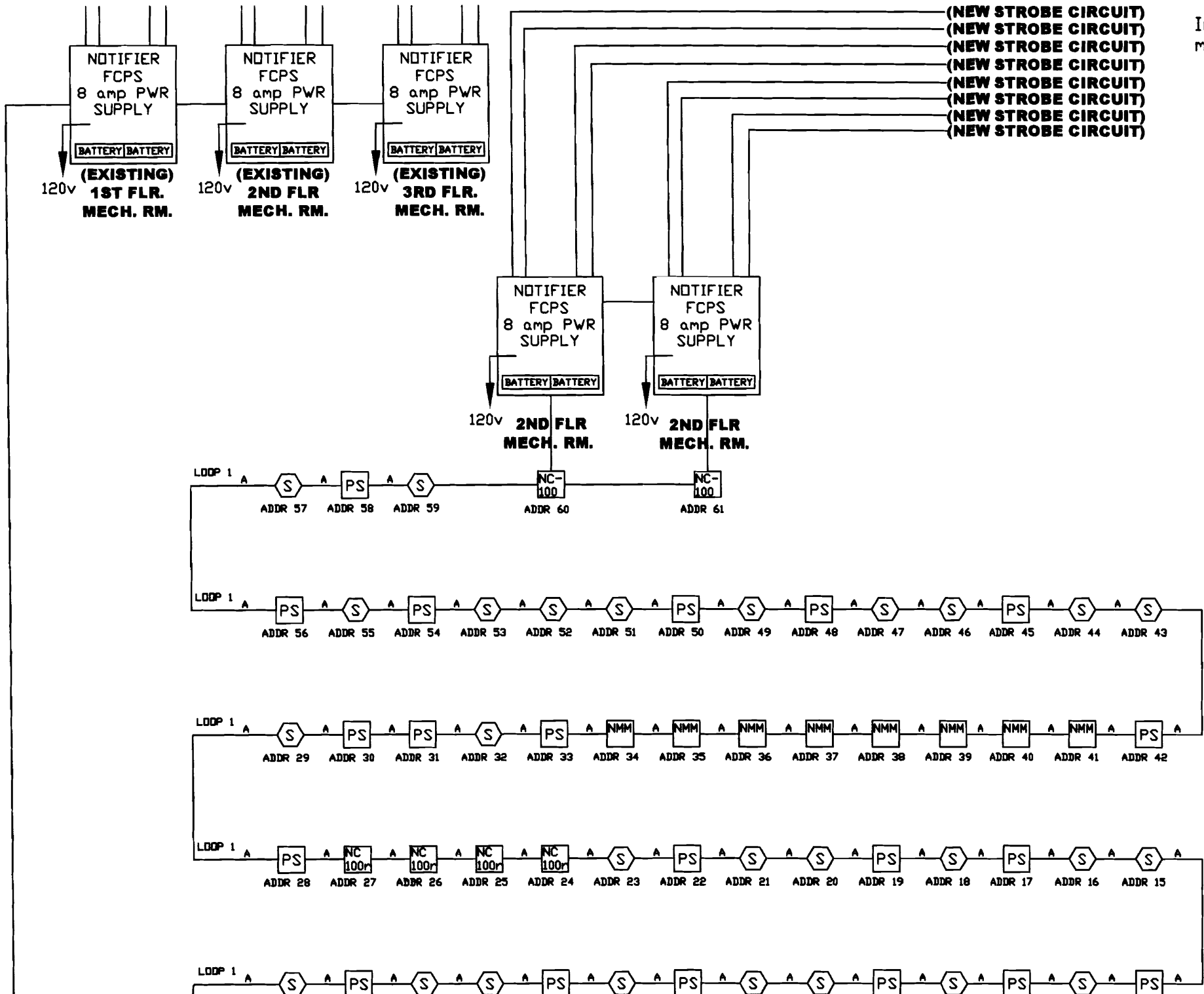

Important  
must have