



Introduction + Project Team



Introduction

The proposed new multi-family building at 97 Cumberland Ave. requires planning board approval given the subdivision of more than two units. The property owner is electing to proceed with a Preliminary Level III Site plan review as suggested by the Planning Department. In addition to the standard requirements of a Level III Site Plan the owner requests that the proposed design be assessed under the Alternate Design Review provision of the R-6 zoning district Design Manual. GO Logic LLC, an Architecture and Construction firm (ME Licensed Architect, Lic #3810), has been hired by the property owner to provide design services to develop the planning for the house and the garage, and has prepared this application on their behalf.

A schematic design and siting of the building have been determined. The bulk and height of the proposed building are in compliance with the R-6 zoning district limitations. In addition, all setbacks have been met along with total lot coverage limitations

Project Description

The property is a 5050 square foot parcel (.12 acre) located at 97 Cumberland Ave. The nearest major intersection is with Washington Ave. The existing use of the property is single-family residential; a vacant single-family house has been demolished by the property owner.

The property shares an access easement with the neighboring properties of 93 Cumberland Ave. and 93 Rear Cumberland Ave. The easement is disclosed in the deed to the property and survey included with this submittal. The property owner intends to maintain and improve this access.

No accessory structures are currently planned on the property.

Project Team

Property Owner – Peter & Annie Dugas

Architect – GOL Logic, LLC; Timothy Lock, Project Architect

Surveyor – Owen Haskell

Civil Engineer – Sebago Technics

Structural Engineer – Albert Putnam, PE

Mechanical Engineer – Andrew McPartland, PE



Code + Zoning Assesment



Lot Information

Address: 97 Cumberland St.

Block: 013

Summary Of Zoning and Code Regulations

Zoning Restrictions – Based On Portland Zoning Ordinance

Zoning District – R6

Minimum Setback Requirements

Principal Structure

Front: 10 feet (or even with neighboring buildings)
Side: 3 stories – 10 feet
Rear: 20 feet

Lot Restrictions

Gross Area 4500 SF
Minimum Street Frontage: 40 feet
Lot Coverage: 50% maximum up to 20 dwelling units – 2945 SF
Open Space Requirement: 20% of lot area – 1180 SF

Lot Compliance

Gross Area: 5050 SF
Street Frontage: 43 feet
Lot Coverage (Building): 1790 SF
Total Impervious Surface: 2914 SF

Building Bulk

Principle Structure

Floor Area Ratio (FAR): N/A
Building Height Limit: 45 ft. (above average finished grade at fronting street)
Number of Stories: 3 plus Basement
Overall Building Size: 6990 SF
Total Number of Dwelling Units: 5

Use Restrictions and Requirements

Principle Structure

Proposed use: Multi-family housing

Permitted uses:

- Multi-family housing
- Single-family house
- Temporary lodging (hotel, etc.)

- Conditional uses:

- Professional offices and similar business use types

Parking

Required Off-street Parking: 1 space per dwelling unit – 5 spaces provided



G·OLOGIC

architecture • construction

Project Description

97 Cumberland Ave.

Occupying a thin, infill property on the edge of the R-6 district in Munjoy Hill near the intersection of Cumberland Ave. and Washington Avenue, 97 Cumberland Avenue is a proposed small, five-unit multi-family development setting. The property owner is a Portland resident looking to construct a high-performance multi-family building. GO Logic is a Belfast based architecture and construction firm specializing in thermally efficient buildings based on the German Passive House standard. With all of our projects we believe there is an inherent synergy between designing for human comfort and long-term sustainability. If the building's design is based on specific and local climactic conditions well integrated with the building's function, the comfort of occupant and interaction with the site and surrounding buildings will be optimized. When the building envelope is designed and executed well the building will require almost no supplemental heating energy and will provide a stable and comfortable interior environment. The relationship between thermal performance and human comfort results in an inherently compelling architectural response, as climate, form and function work in unison.

Technically, we set a goal for all of our projects to have the energy demand for space heating and cooling reduced to almost zero, allowing for the installation of renewable energy systems to create more energy than is consumed. Our design approach starts with a highly-insulated building shell that makes use of passive solar gain to lower space heating demands, allowing the cost and complexity of the mechanical systems to be minimized. Our target level of energy performance for the building as a whole is the German Passive House standard for space heating and air infiltration, which represents a 90% improvement on the buildings' space heating loads from typical code-complaint construction. These improvements over conventional construction, in conjunction with heat recovery ventilation, result in a building with an extremely small energy demand. Furthermore, due to the minimized heat load, a solar electric system can cover the building's space and domestic water heating demands in most climate regions, resulting in a cost-effective, grid-tied, Energy-Plus building as measured on an annual basis. While all of our projects are designed and built to these standards, we have had officially certified three single-family residences in Maine, Connecticut, and Michigan and one dormitory for Unity College in Unity, Maine. In addition, we have certification pending on the first certified Passive House laboratory in North America for the University of Chicago and a fourth single family residence in Western Massachusetts. We are bringing this design approach to a multi-family building, for the first time, at 97 Cumberland Avenue. It is on track to be the first certified multi-family Passive House in the state of Maine.

The constrained site and solar orientation of 97 Cumberland poses thermal performance challenges. While we would typically take advantage of the sunny Maine winter to provide additional passive solar heating, we have taken different approach here, resulting a more compact building, in keeping with the mass of the surrounding buildings and scale of typical fenestration in the neighborhood. In order to increase the thermal performance for the larger building, the building is divided into two parts by an enclosed common stair allowing each structure to minimize the ratio of exterior wall to enclosed volume. Four one-bedroom apartments and one two-story three-bedroom are spread between the two structures effectively reducing the perceived scale of building as a whole. The site slopes down to the rear of the property allowing covered parking under the back building and reducing the building height along the street front. The roof of the front building is pitched on an angle towards solar south to accommodate a photovoltaic array while the rear building offers a common roof deck surrounded by a screen wall supporting climbing vines continuing down the common stair. We are proposing an exterior finish in keeping with the neighboring industrial buildings along Washington Avenue. We are applying for an Alternative Design Review on this project.



Design Principals + Standards

Overall Context

The neighborhood surrounding 97 Cumberland Avenue is unique in that it is a hinge-point between the large-scale, masonry industrial aesthetic of the buildings lining the north side of Washington Avenue and the two and three story clap-board-sided residential buildings of Cumberland Avenue.

While the property is accessed only from Cumberland Avenue, the surrounding topography and grade of Cumberland Avenue allows the West side façade to be fully visible from Washington Street above a gas station and convenient store at 21 Washington Ave.



The proposed design attempts to negotiate this divide by establishing an industrial-scale west façade facing Washington Avenue. The South façade, facing Cumberland Avenue, takes advantage of the rise in grade toward Cumberland Ave. effectively reducing the height of the building along this more residential street to three stories keeping it consistent with other multi-family buildings to the east.

Additionally, the proposed fenestration coordinates the scale of masonry openings along Washington Avenue with smaller, residential scale openings while maintaining a proportion of un-fenestrated wall consistent with surrounding buildings. We have included several examples of buildings with similar features to those describing our proposal below in the surrounding neighborhood.



Site viewed from Washington Ave - Existing



Site viewed from Washington Ave - Proposed



63 Washington Ave



5 Washington Ave



129 Washington Ave



97 Cumberland Ave: Rendering



96 Sheridan St



59 Cumberland Ave



97 Cumberland Ave

Massing

The intent of the proposed massing of the new building at 97 Cumberland Ave. is, as noted above, to maintain the size and scale of the residential buildings along Cumberland Ave. when viewed from the Northeast while responding to the form and of industrial masonry buildings when viewed from the West along Washington Avenue.

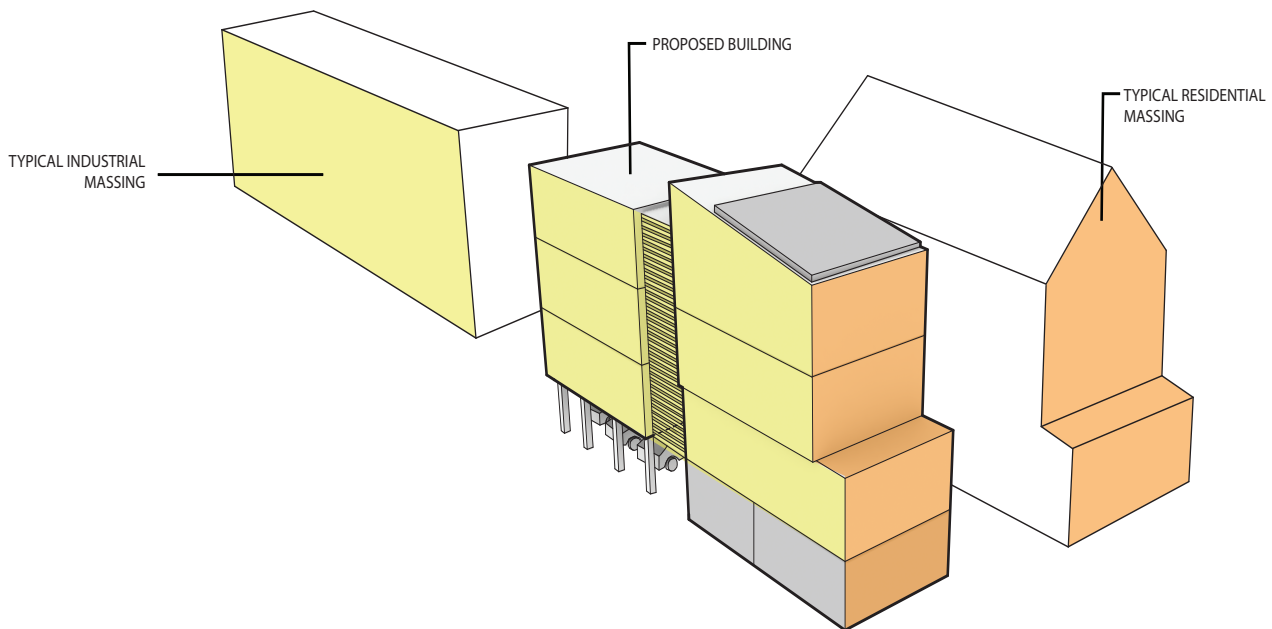

By dividing the building into two structures with a common stair the impression of the overall mass is reduced. The separation between the structures is mitigated by a planted wall of climbing vines, providing shade to the enclosed common stair and a further break in the overall building mass. Further breaking down the mass of the building as viewed along Cumberland Ave., the ground floor dwelling unit extends to the front yard set back providing a recessed and covered ground floor entry and a balcony for the 2nd floor dwelling unit. This serves to further breakdown the mass at the street and reduce the impact of the three-story height by reflecting the mass of traditional porch structures and extended bay windows in the surrounding neighborhood.

(front rendering with everything but entry porch desaturated)

While the north structure utilizes a flat roof similar to the surrounding masonry buildings, the south building at Cumberland Avenue has a single pitched shed roof oriented specifically to solar south generating a roof form designed to maximize electricity production. The resulting roof area is sufficient to power the heating and cooling systems for both structures. Several instances of single pitched shed roofs are present in the surrounding neighborhood.



97 Cumberland Ave. - Proposed



96 Sheridan St.



3 Greenleaf St.

Again, utilizing the natural grade of the site, we have situated an accessory garage under the north structure providing discrete parking concealed from view from the street.

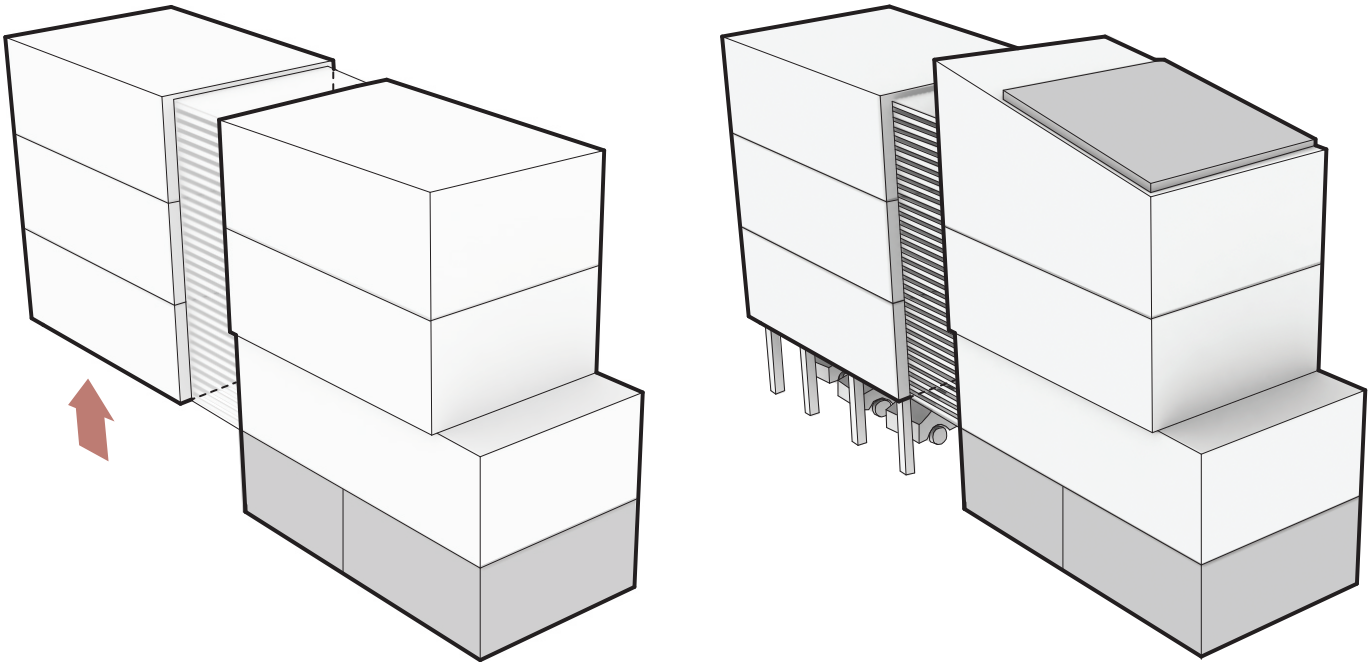

Parking Diagram

Orientation To Street

We have situated the building to provide clear entry from the street frontage along Cumberland Avenue. The first floor dwelling has direct access to the front yard through a covered and recessed entry deck providing privacy from the street. The finished floor elevation of the street level unit is two feet above the highest portion of public sidewalk, further shielding it from the street. The main access to the common enclosed stair follows an elevated walkway deck effectively separating the common entry from the street level dwelling unit at the street. The walkway is clearly delineated from the site access point along the east edge of the property.



97 Cumberland Ave. - Proposed Front Entry



G·OLOGIC

architecture • construction

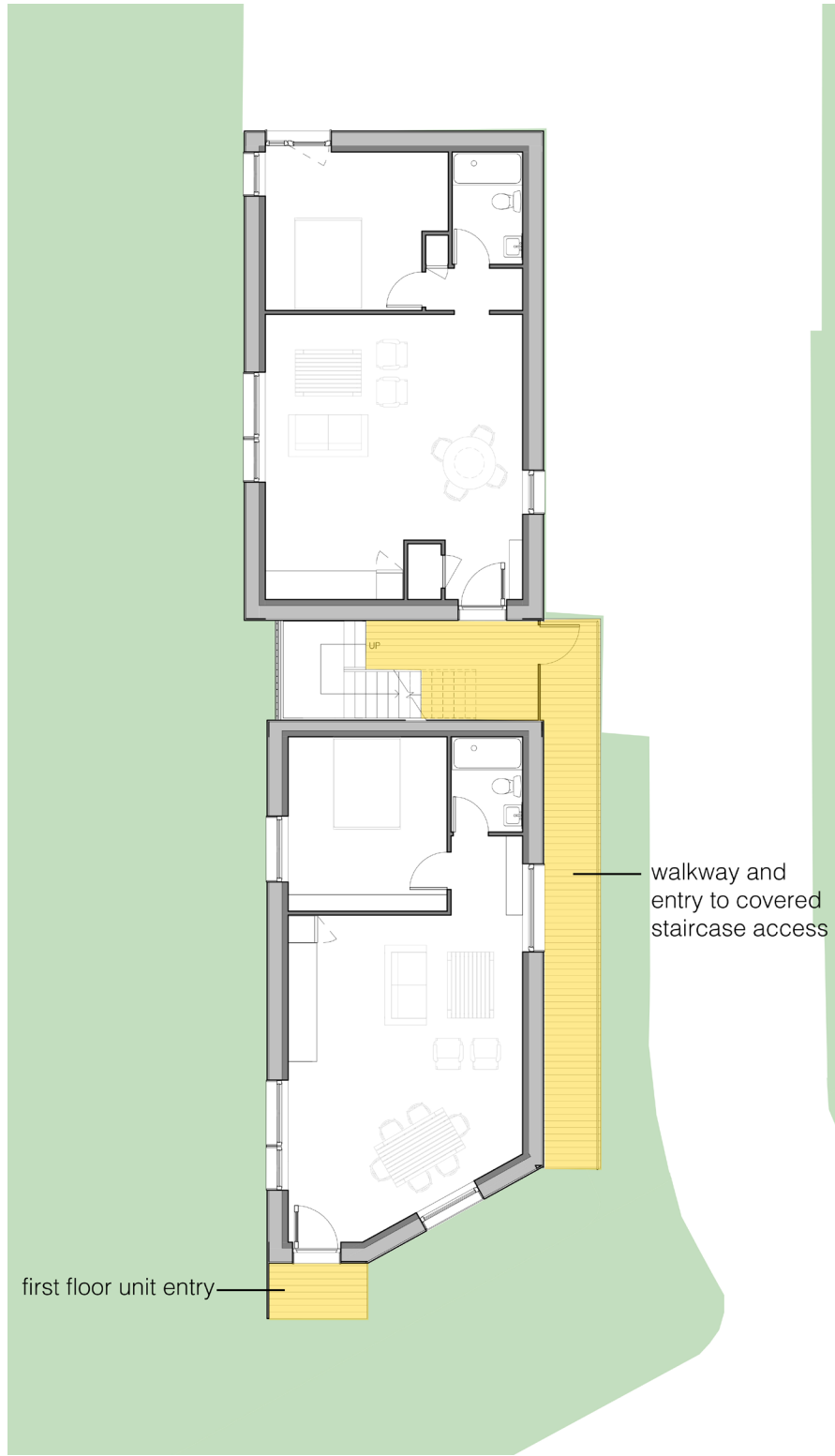

97 Cumberland Ave. - Plan Diagram at Entry

Proportions and Scale

The proposed building attempts to replicate the proportions and scale of the surrounding residential buildings in height and width. We have paired this compact building scale with fenestration along the façade reflecting the proportions and scale of the glazed openings of the industrial buildings along Washington Avenue.

The surrounding residential buildings lining Cumberland Avenue are, in general, three stories in height and approximately twenty to twenty five feet wide. We have maintained these proportions on the façade facing Cumberland Avenue.

Balance and Articulation

The proposed design strives to maintain a consistency of fenestration throughout within a contemporary architectural language. The openings consist of a repetition of two window sizes. The window heights are consistent on each façade. Further, all window openings are aligned along horizontal datum lines delineating floors.

One tall, vertical window outlines an interior stair of a two-story dwelling unit on the Cumberland Avenue façade. To reduce total building heat loss, the windows on the North and East facades are smaller, but consistent in size.



63 Washington Ave. - Fenestration

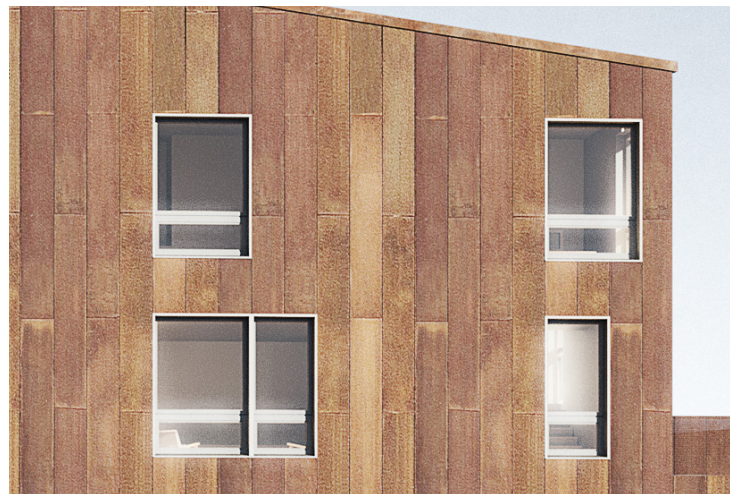

97 Cumberland Ave. - Proposed Fenestration



59 Cumberland Ave. - Fenestration



97 Cumberland Ave. - Proposed Fenestration

While the building is contemporary in architectural language, we have included modern versions of classic building articulations. All windows are trimmed to the exterior finish in a contrasting finish to the building cladding. The roof fascia provides delineation to the roof line, yet is matched in material to the façade. We have been careful to limit the material palette to the cladding and contrasting trim throughout. Porches (both the entry porch to the first floor dwelling unit along Cumberland Avenue and the main entry porch to the common stair are carefully fit within the overall building volume. Materials



Given the position of the property within the existing local urban context, we feel it is important to establish a visual and material relationship with the industrial buildings along Washington Avenue. We have chosen a metal panel exterior cladding in a rust-red finish to reflect the color and texture of the surrounding masonry buildings.



63 Washington Ave. - Red Brick Material Finish



97 Cumberland Ave. - Proposed Rust-Red Metal Panel Finish



G.OLOGIC

architecture • construction







G·OLOGIC

architecture • construction



