

DIMENSIONS

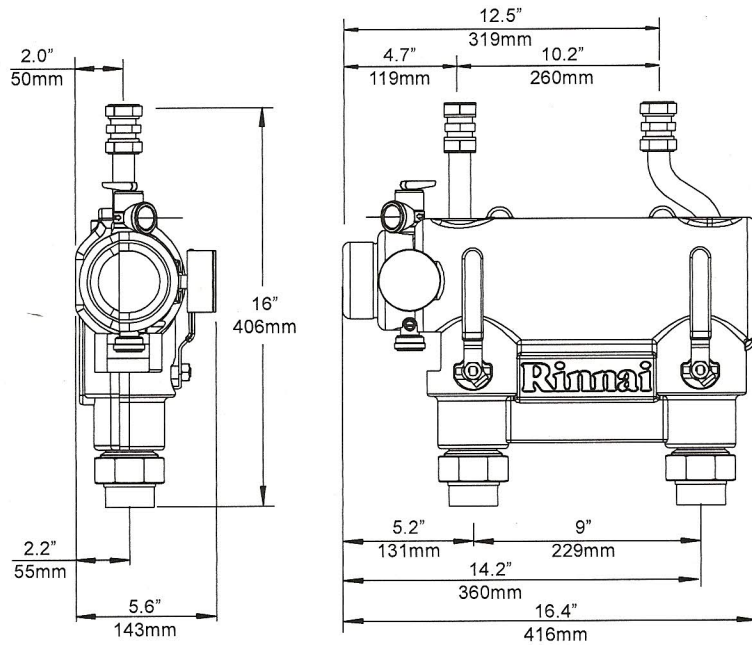
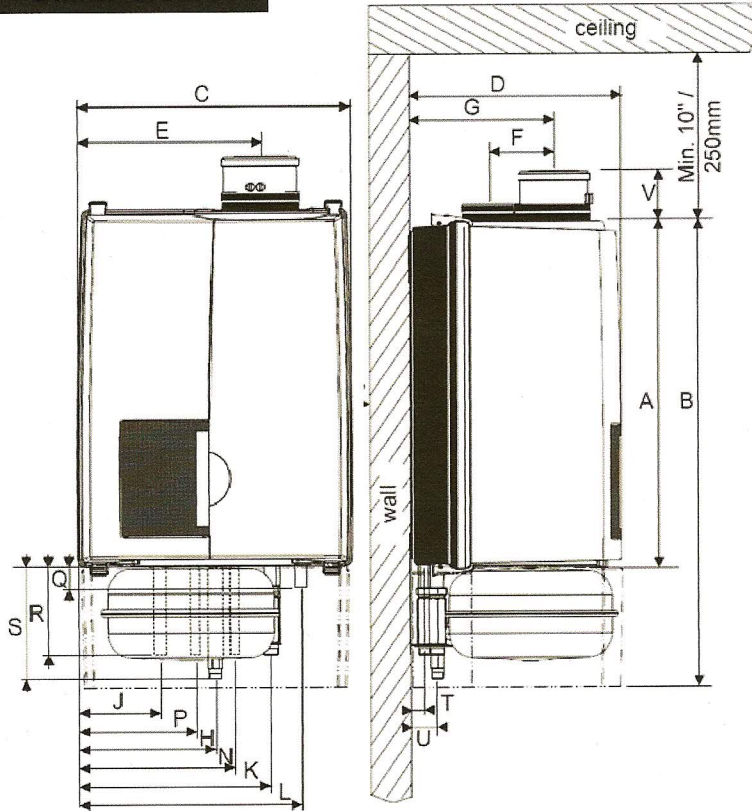

		E75C	E110C
		inch / mm	
A	Height	25.6 / 650	
B	Height with expansion tank	NA	34.3 / 870
C	Width	19.7 / 500	
D	Depth	15.6 / 395	
E	Left side / vent	13.2 / 335	
F	Center to center / vent and air supply	4.7 / 120	
G	Back / vent	10.6 / 270	
H	Left side / gas pipe	9.8 / 250	
J	Left side / supply pipe	5.9 / 150	
K	Left side / return pipe	13.8 / 350	
L	Left side / condensate pipe	15.9 / 405	
N	Left side / cold water pipe	11.2 / 285	
P	Left side / hot water pipe	8.5 / 215	
Q	Pipe length of g	0.7 / 19	8.5 / 215
R	Pipe length of c	1.6 / 40	
S	Pipe length of f, k, r, and w	2 / 50	6.3 / 160
T	Back / center of pipe c, k, and w	1 / 26	
U	Back / Center of pipe f, g, and r	2 / 50	
V	Pipe length vent co-axial Pipe length vent parallel	3.7 / 95 7 / 177	

Clearances

	Minimum required clearance to combustibles and non-combustibles	Recommended service clearances
	inch / mm	inch / mm
Top	2 / 50	10 / 250
Back	0	0
Front	6 / 150	24 / 600
Left side	2 / 50	2 / 50
Right side	2 / 50	2 / 50
Floor / Ground	12 / 300	30 / 762
Vent	0	0