

1 UNIT 2A KITCHEN - TYP. UNIT
SCALE: 1/2" = 1'-0"

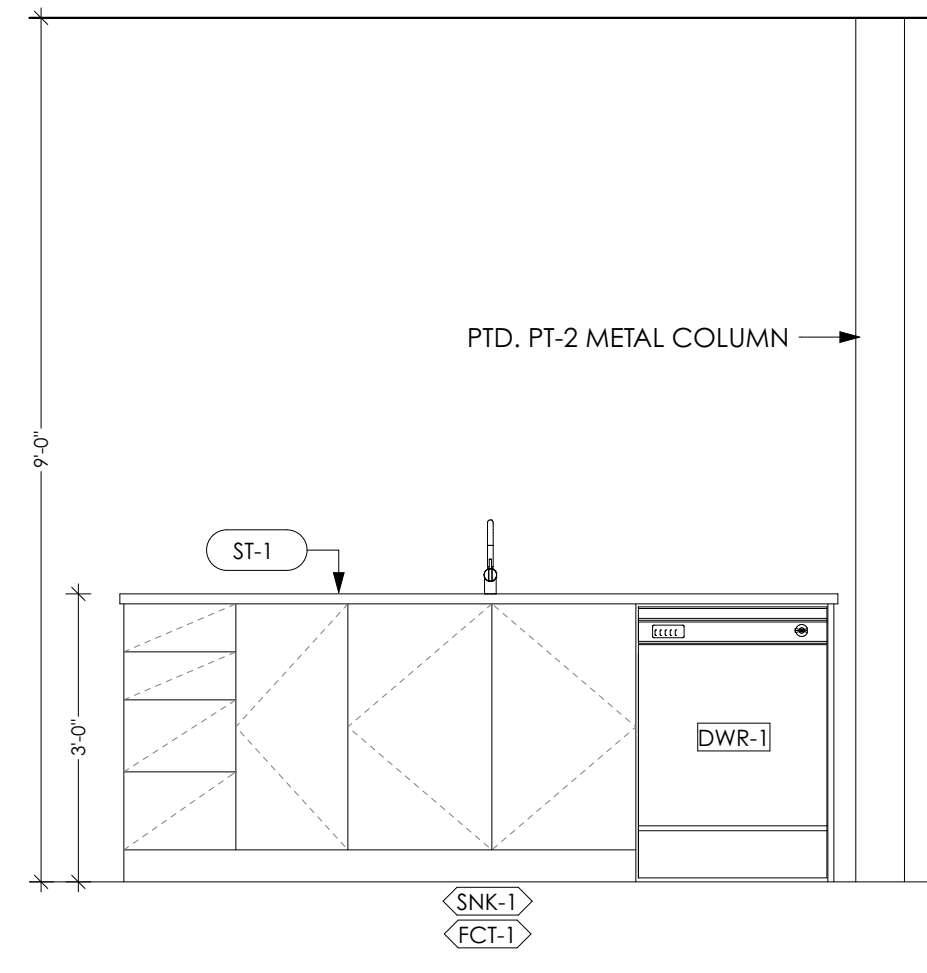

2 UNIT 2A KITCHEN - TYP. UNIT
SCALE: 1/2" = 1'-0"

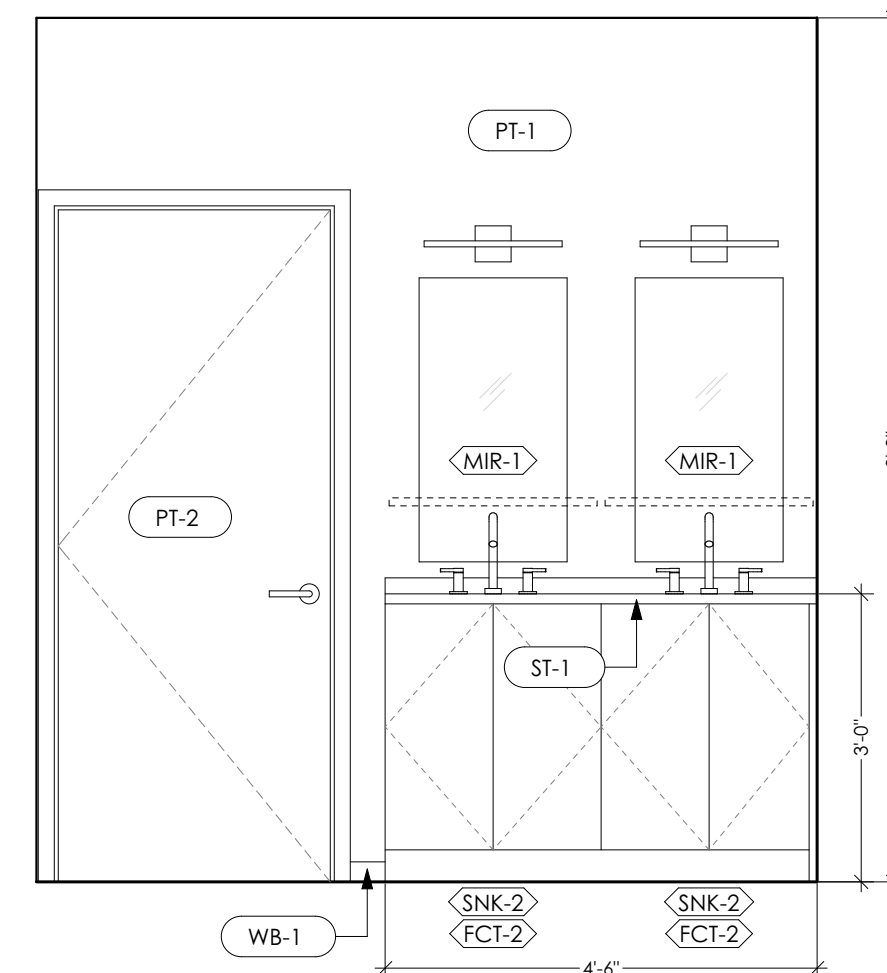

3 UNIT 2A MASTER BATH - TYP. UNIT
SCALE: 1/2" = 1'-0"

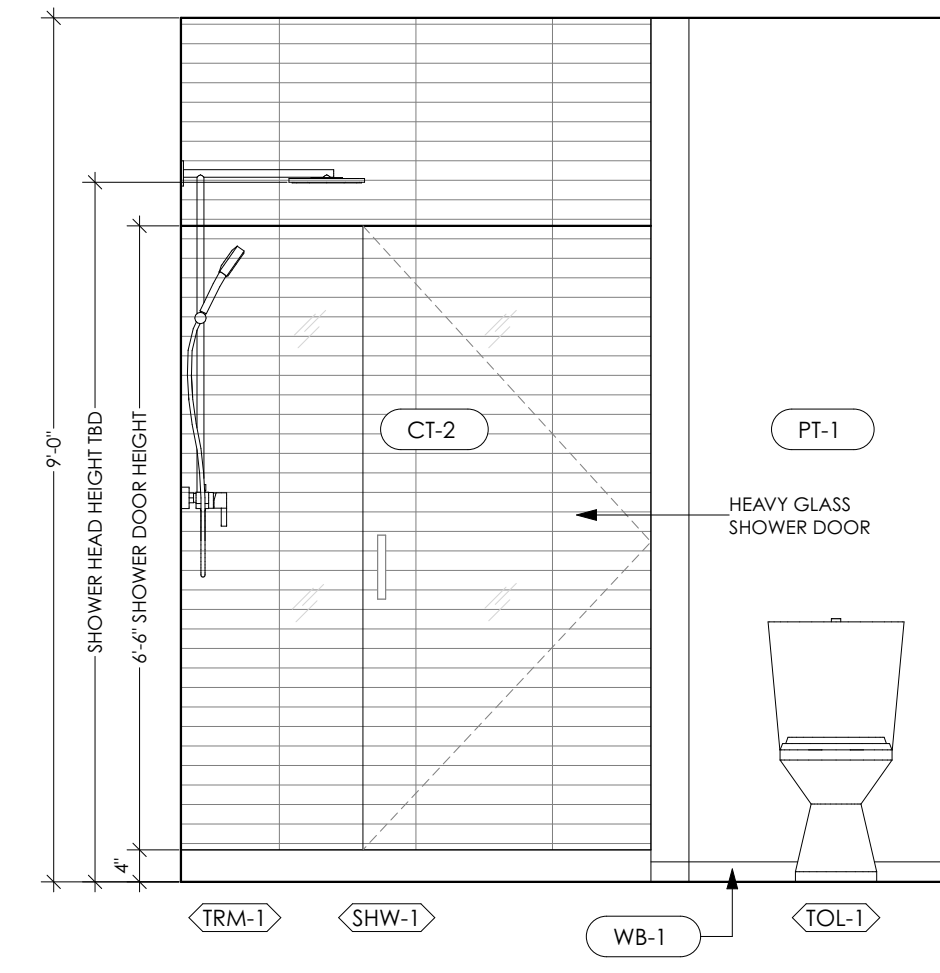

4 UNIT 2A MASTER BATH - TYP. UNIT
SCALE: 1/2" = 1'-0"

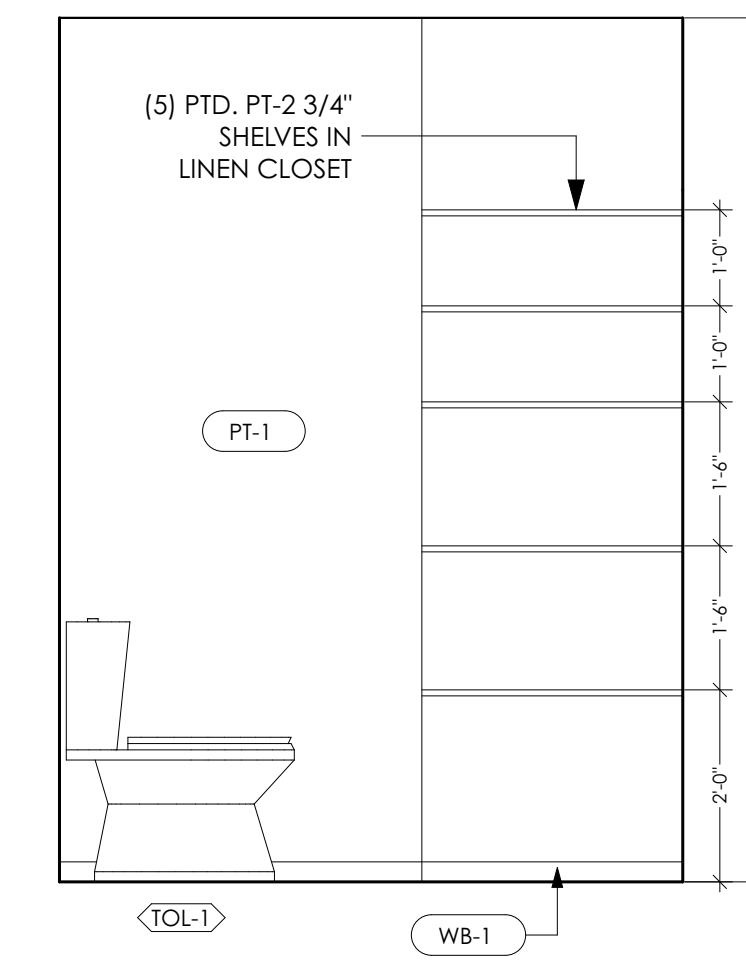

5 UNIT 2A MASTER BATH - TYP. UNIT
SCALE: 1/2" = 1'-0"

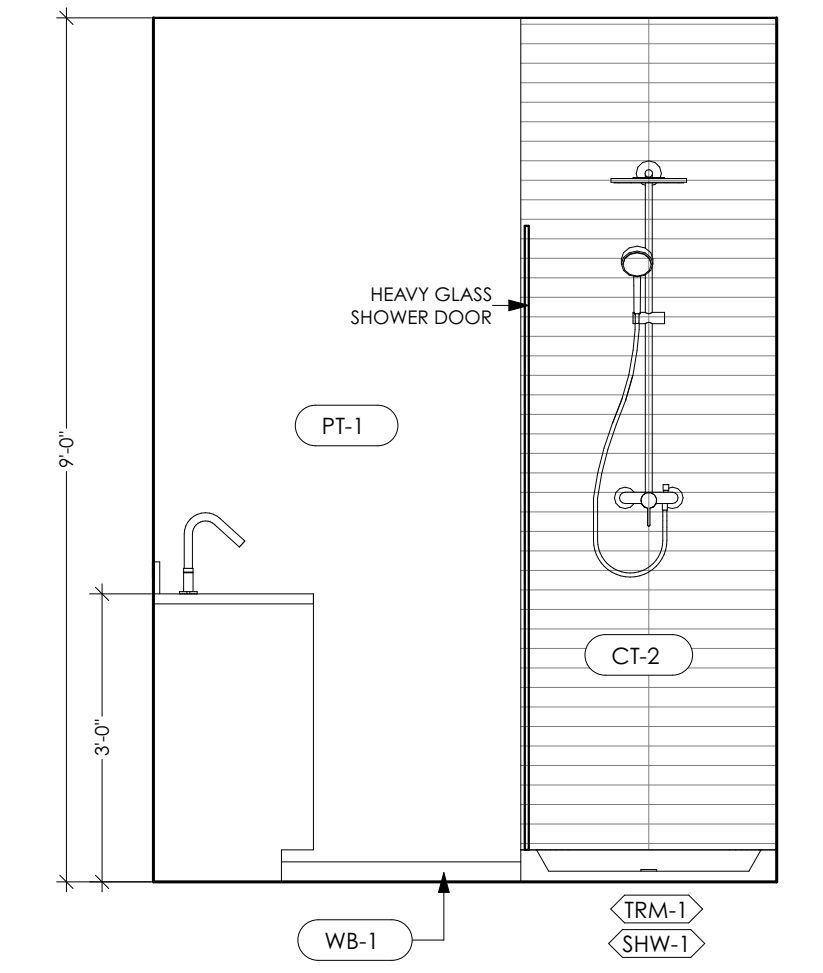

6 UNIT 2A MASTER BATH - TYP. UNIT
SCALE: 1/2" = 1'-0"



CALEB JOHNSON
ARCHITECTS + BUILDERS
110 EXCHANGE ST. FLOOR 2 PORTLAND, ME 04101
T: 207.283.8777 F: 207.283.8778 C: JAB.ME

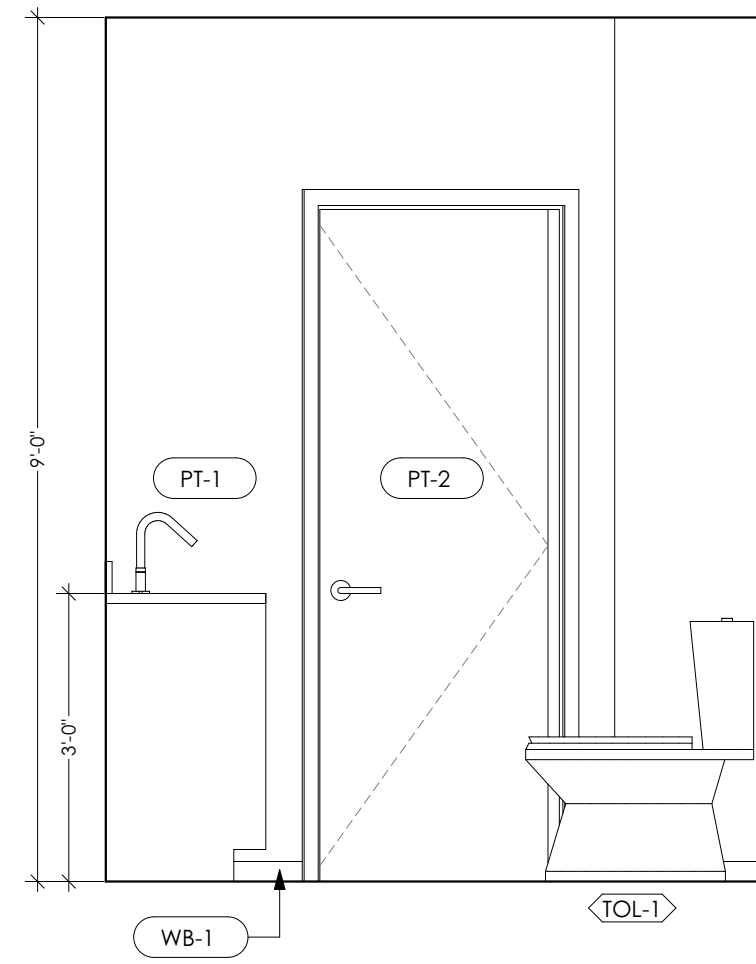

7 UNIT 2A GUEST BATH - TYP. UNIT
SCALE: 1/2" = 1'-0"

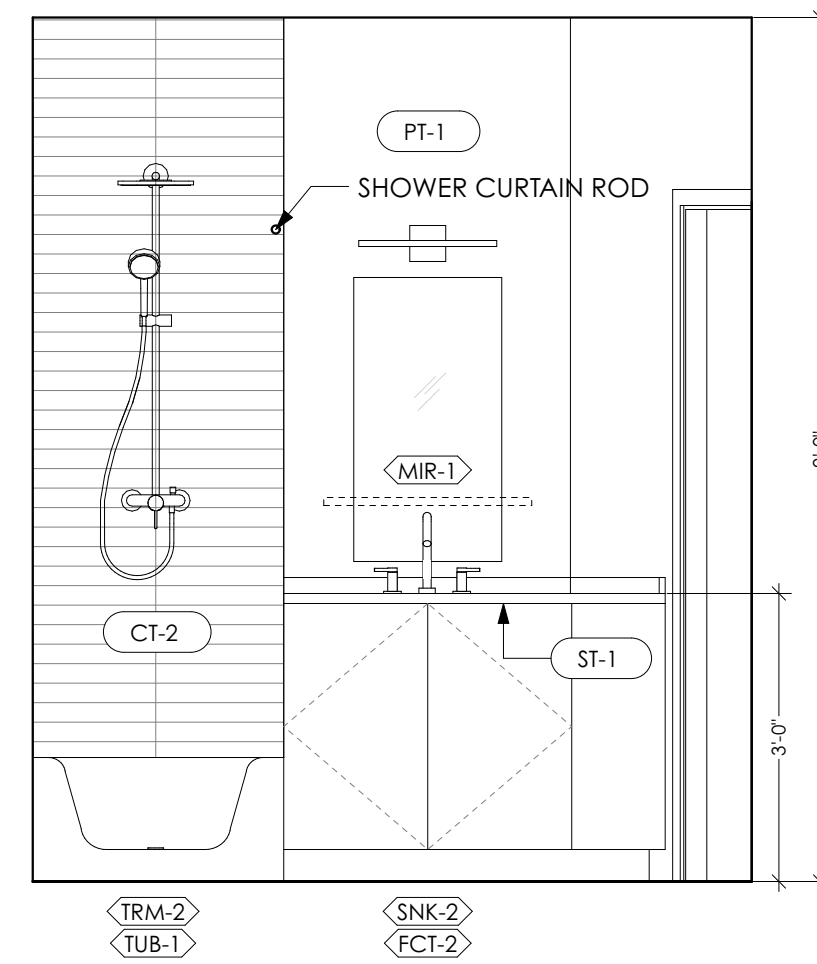

8 UNIT 2A GUEST BATH - TYP. UNIT
SCALE: 1/2" = 1'-0"

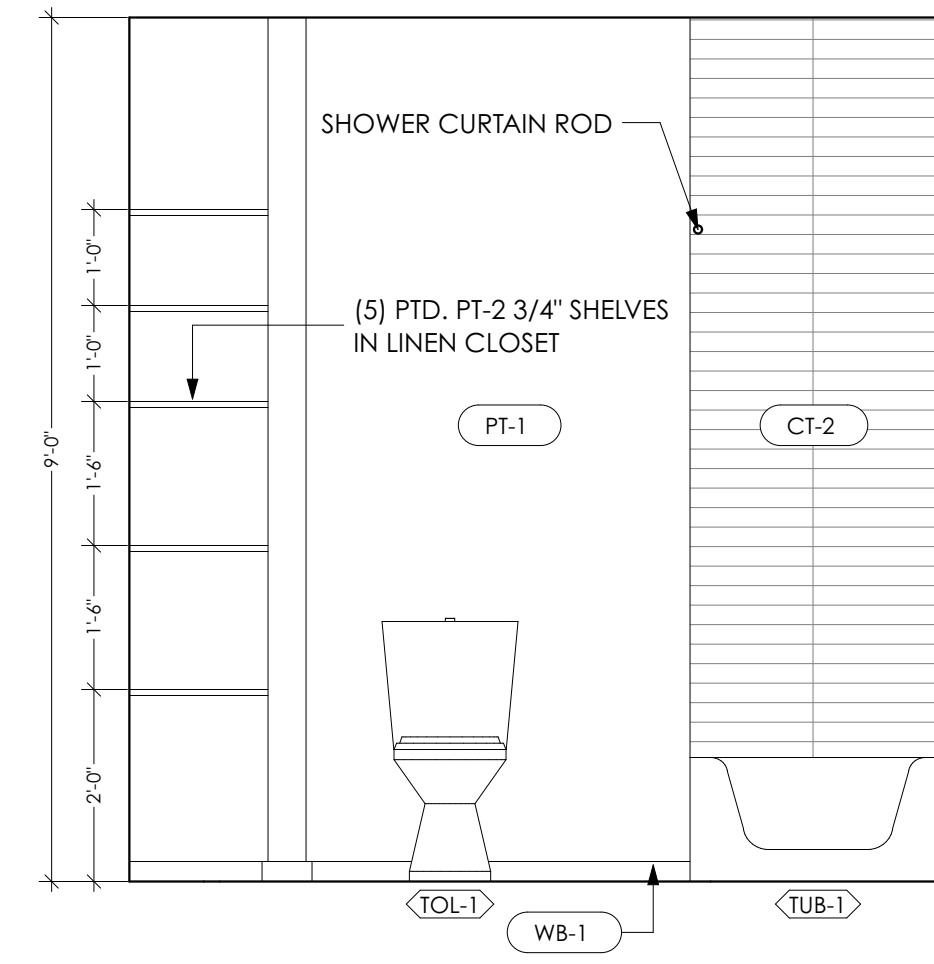

9 UNIT 2A GUEST BATH - TYP. UNIT
SCALE: 1/2" = 1'-0"

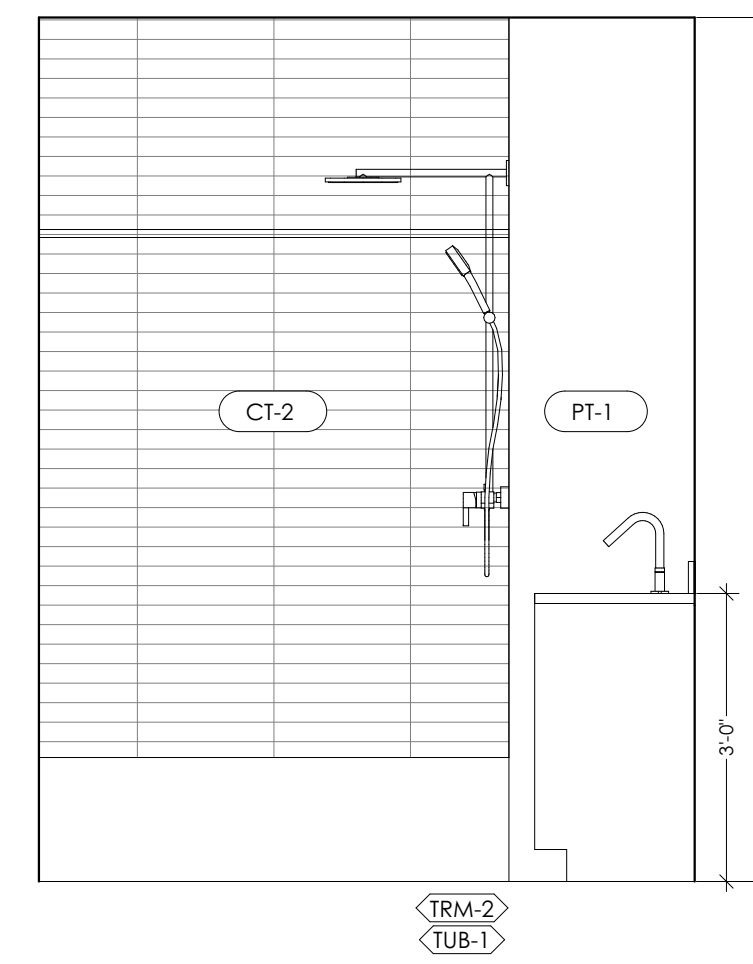

10 UNIT 2A GUEST BATH - TYP. UNIT
SCALE: 1/2" = 1'-0"

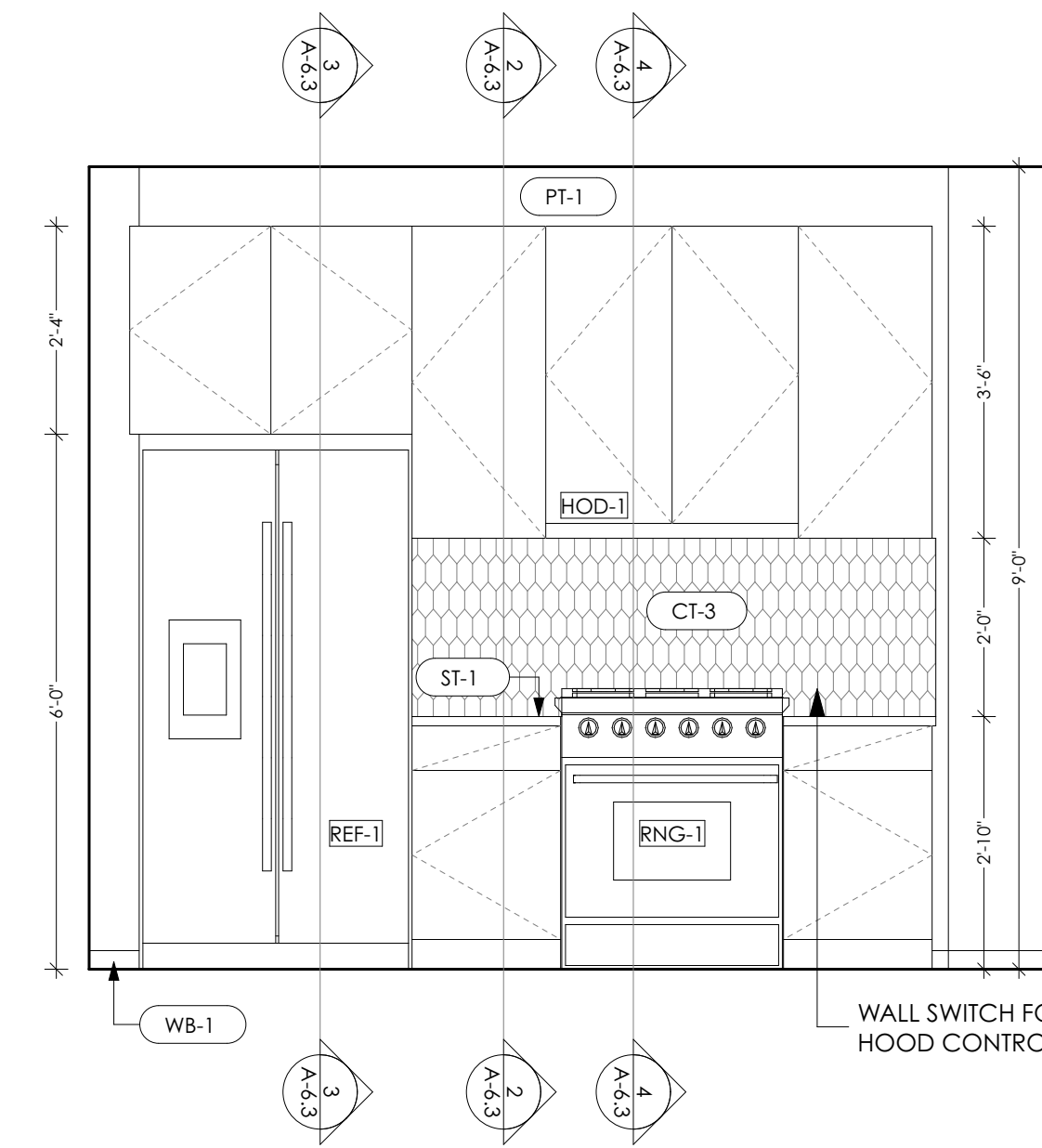

11 UNIT 2E KITCHEN - TYPE "A"
SCALE: 1/2" = 1'-0"

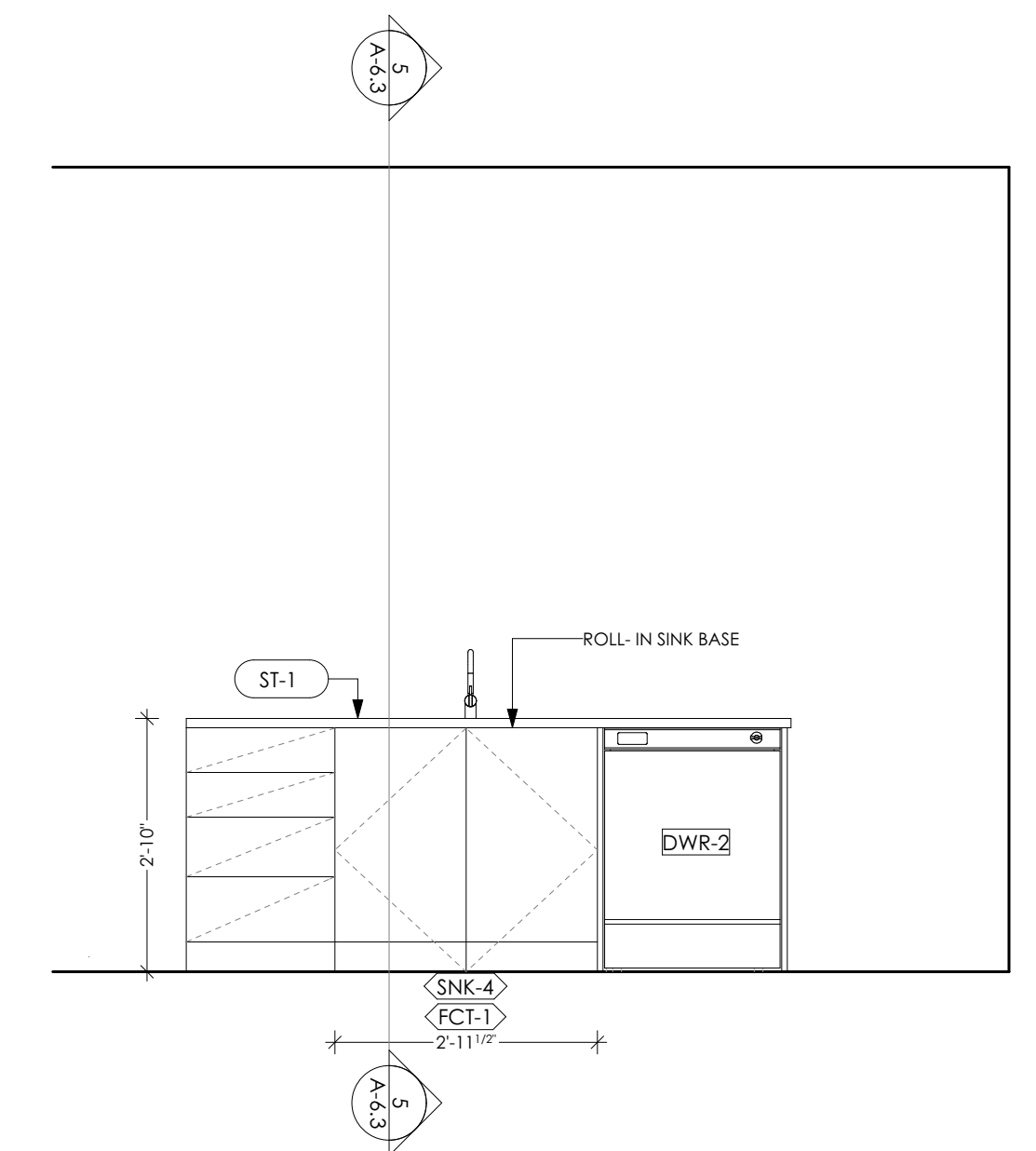

12 UNIT 2E KITCHEN - TYPE "A"
SCALE: 1/2" = 1'-0"

INTERIOR ELEVATION GENERAL NOTES

- All fixture heights and clearances to follow all respective requirements described in the 2010 ADA Standards for Accessible Design for Type "A" and Type "B" Residential Dwelling Units. Refer to mounting height diagrams in these drawings.
- Refer to Finish Schedule for Room Finishes
- Refer to Plumbing Schedule for all Plumbing Fixtures
- Refer to Lighting Schedule for Vanity Lights
- Schluter Jolly Edging at all tile edges. Finish: Brushed Stainless Steel
- Provide Shower and Tub Curtain Rods at all Guest Bath Locations U.N.O.

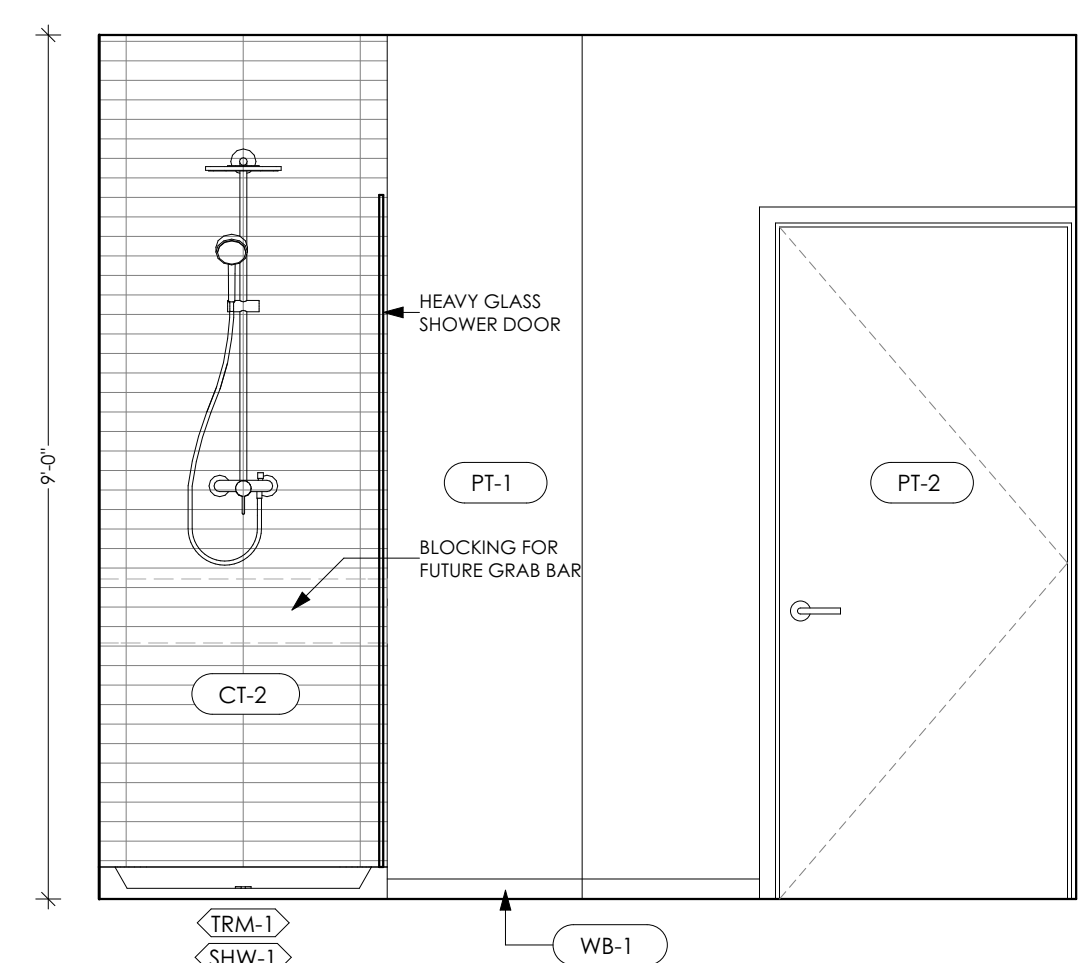

13 UNIT 2E MASTER BATH - TYPE "A"
SCALE: 1/2" = 1'-0"

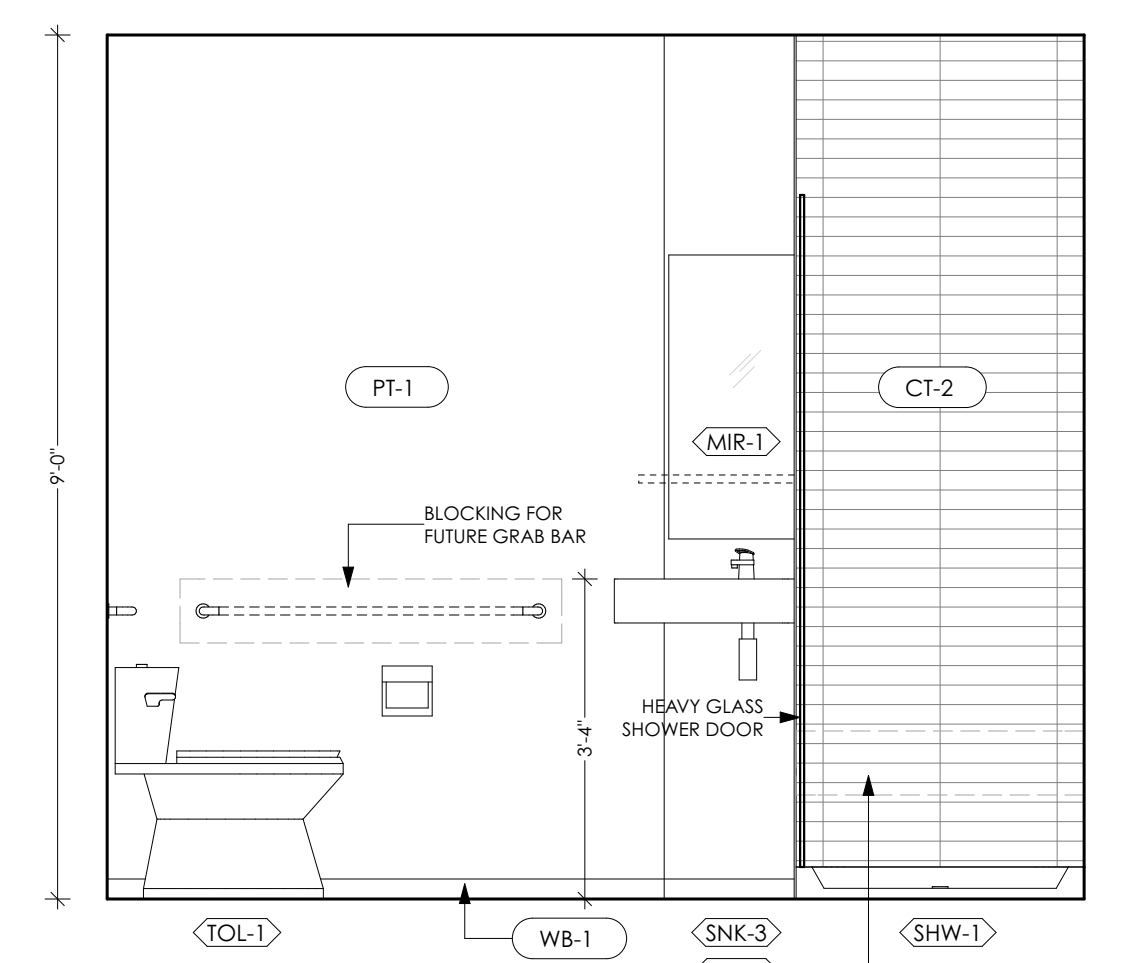

14 UNIT 2E MASTER BATH - TYPE "A"
SCALE: 1/2" = 1'-0"

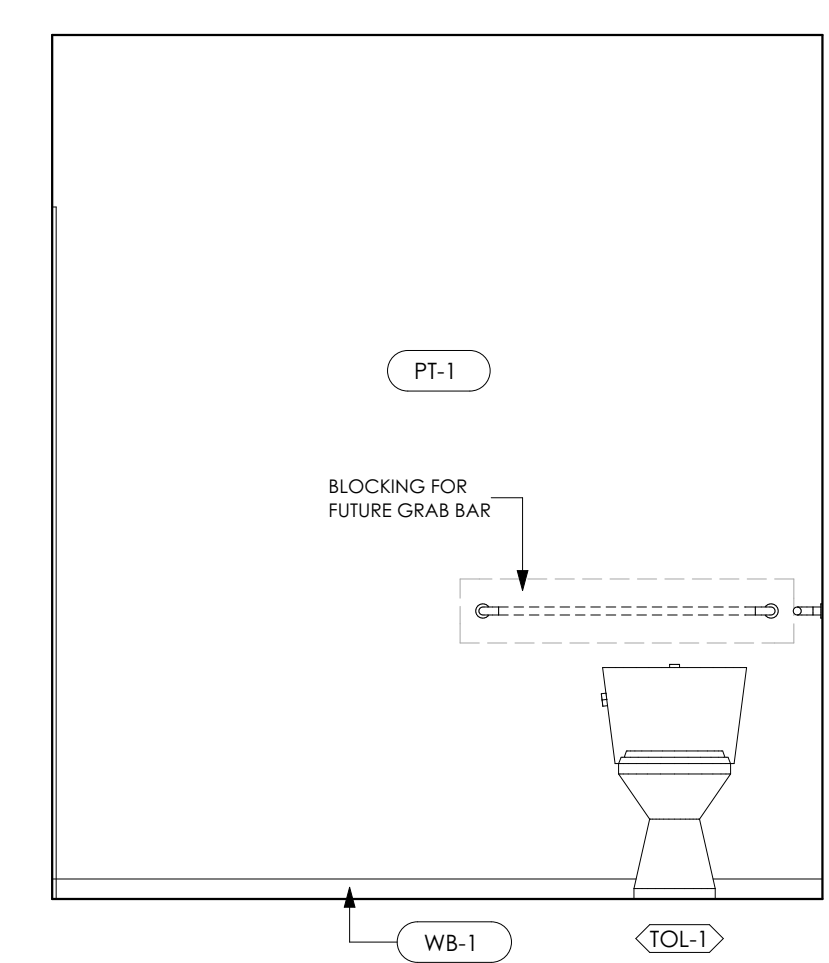

15 UNIT 2E MASTER BATH - TYPE "A"
SCALE: 1/2" = 1'-0"

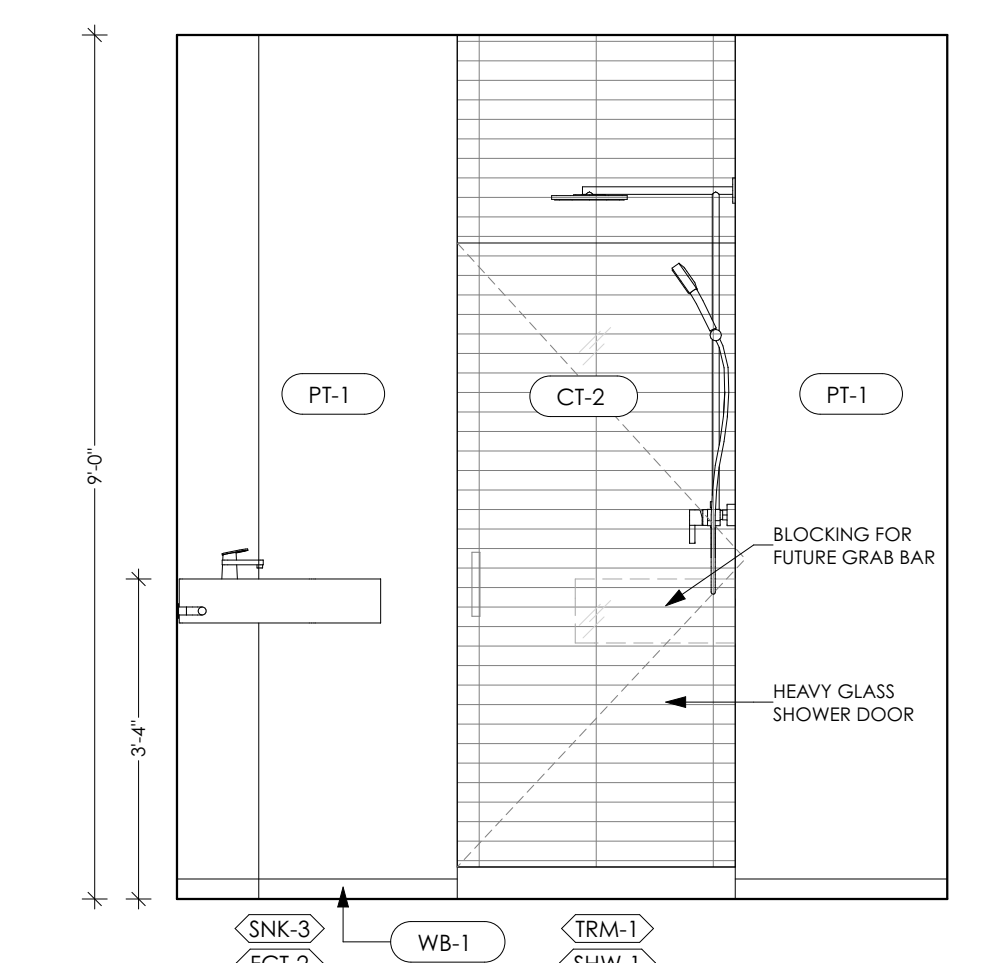

16 UNIT 2E MASTER BATH - TYPE "A"
SCALE: 1/2" = 1'-0"

PERMIT SET

DATE: 7/21/17
PROJECT STATUS: Permit Set

221 Congress Street
Hay Runner Block
221 BLOCK, LLC
221 Congress Street Portland ME 04101

UNIT INTERIOR ELEVATIONS
A-6.2