

City of Portland, Maine - Building or Use Permit Application

389 Congress Street, 04101 Tel: (207) 874-8703, Fax: (207) 874-8716

Permit No: 06-1604	Issue Date:	CBL: 013 G010001
-----------------------	-------------	---------------------

Location of Construction: 223 CONGRESS ST	Owner Name: MAJE IN MAINE LLC	Owner Address: APT H 605 8617 PINE ST	Phone:
Business Name:	Contractor Name: Avery Services, Inc.	Contractor Address: 7 Thomas Drive Westbrook	Phone 2077728687
Lessee/Buyer's Name	Phone:	Permit Type: HVAC	Zone: B2b

Past Use: Multi Use	Proposed Use: Multi Use install a Carrier heating system	Permit Fee: \$250.00	Cost of Work: \$23,000.00	CEO District: 1
Proposed Project Description: Install a carrier heating system <i>legal use: 1st floor taken w/ th office & 3 residential D.U. in rest of Bldg</i>		FIRE DEPT: <input checked="" type="checkbox"/> Approved <input type="checkbox"/> Denied <i>NO unvented GAS units</i>	INSPECTION: Use Group: <i>R2/A2</i> Type: <i>HVAC</i> <i>IMC 2003</i>	
		Signature: <i>Greg Case</i>	Signature: <i>[Signature] 14/03/06</i>	
PEDESTRIAN ACTIVITIES DISTRICT (P.A.D.) Action: <input type="checkbox"/> Approved <input type="checkbox"/> Approved w/Conditions <input type="checkbox"/> Denied Signature: _____ Date: _____				

Permit Taken By: dmartin	Date Applied For: 11/01/2006	Zoning Approval	
-----------------------------	---------------------------------	------------------------	--

1. This permit application does not preclude the Applicant(s) from meeting applicable State and Federal Rules. 2. Building permits do not include plumbing, septic or electrical work. 3. Building permits are void if work is not started within six (6) months of the date of issuance. False information may invalidate a building permit and stop all work..	Special Zone or Reviews <input type="checkbox"/> Shoreland <input type="checkbox"/> Wetland <input type="checkbox"/> Flood Zone <input type="checkbox"/> Subdivision <input type="checkbox"/> Site Plan Maj <input type="checkbox"/> Minor <input type="checkbox"/> MM <input type="checkbox"/> <i>OK w/ conditions</i> Date: <i>3/14/06</i>	Zoning Appeal <input type="checkbox"/> Variance <input type="checkbox"/> Miscellaneous <input type="checkbox"/> Conditional Use <input type="checkbox"/> Interpretation <input type="checkbox"/> Approved <input type="checkbox"/> Denied Date: _____	Historic Preservation <input checked="" type="checkbox"/> Not in District or Landmark <input type="checkbox"/> Does Not Require Review <input type="checkbox"/> Requires Review <input type="checkbox"/> Approved <input type="checkbox"/> Approved w/Conditions <input type="checkbox"/> Denied Date: _____
--	--	--	---

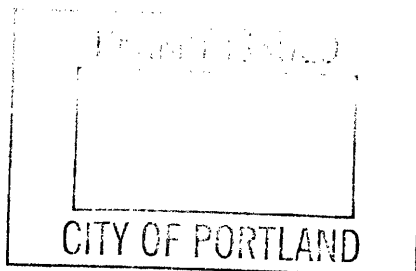

CERTIFICATION

I hereby certify that I am the owner of record of the named property, or that the proposed work is authorized by the owner of record and that I have been authorized by the owner to make this application as his authorized agent and I agree to conform to all applicable laws of this jurisdiction. In addition, if a permit for work described in the application is issued, I certify that the code official's authorized representative shall have the authority to enter all areas covered by such permit at any reasonable hour to enforce the provision of the code(s) applicable to such permit.

SIGNATURE OF APPLICANT	ADDRESS	DATE	PHONE
RESPONSIBLE PERSON IN CHARGE OF WORK, TITLE		DATE	PHONE



FILL IN AND SIGN WITH INK

13 G 10

APPLICATION FOR PERMIT HEATING OR POWER EQUIPMENT

To the INSPECTOR OF BUILDINGS, PORTLAND, ME.

The undersigned hereby applies for a permit to install the following heating, cooking or power equipment in accordance with the Laws of Maine, the Building Code of the City of Portland, and the following specifications:

Location / CBL _____ Use of Building Bar/Furniture Store Date 10/30/06
 Name and address of owner of appliance MAJE IN MAINE 223 CONGRESS STREET
Portland, ME 04101
 Installer's name and address Avery Services Inc. 7 Thomas Drive
Westbrook, ME 04092 Telephone 772-8687 F#874-0933

Location of appliance:

- Basement Floor
 Attic Roof

Type of Fuel:

- Gas Oil Solid

Appliance Name:

CARRIER

U.L. Approved Yes No

Will appliance be installed in accordance with the manufacture's installation instructions? Yes No

IF NO Explain: _____

Type of Chimney:

Masonry Lined
Factory built _____

Metal
Factory Built U.L. Listing # _____

Direct Vent
Type PVC UL# _____

Type of Fuel Tank

N/A

- Oil
 Gas

Size of Tank N/A

Number of Tanks NA

Distance from Tank to Center of Flame NA feet.

Cost of Work: \$ 23,000.00

Permit Fee: \$ 250.00

The Type of License of Installer:

- Master Plumber # _____
 Solid Fuel # _____
 Oil # _____
 Gas # PNT1431
 Other _____

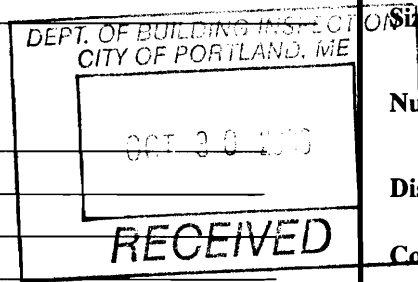

Approved

Fire: _____
 Ele.: _____
 Bldg.: _____

Approved with Conditions

- See attached letter or requirement

[Signature]
Inspector's Signature

11/03/06
Date Approved

Signature of Installer [Signature]

White - Inspection Yellow - File Pink - Applicant's Gold - Assessor's Copy

032194

City of Portland, Maine - Building or Use Permit

389 Congress Street, 04101 Tel: (207) 874-8703, Fax: (207) 874-8716

Permit No: 06-1604	Date Applied For: 11/01/2006	CBL: 013 G010001
------------------------------	--	----------------------------

Location of Construction: 223 CONGRESS ST	Owner Name: MAJE IN MAINE LLC	Owner Address: APT H 605 8617 PINE ST	Phone:
Business Name:	Contractor Name: Avery Services, Inc.	Contractor Address: 7 Thomas Drive Westbrook	Phone: (207) 772-8687
Lessee/Buyer's Name	Phone:	Permit Type: HVAC	

Proposed Use: Multi Use install a Carrier heating system	Proposed Project Description: Install a carrier heating system
--	--

Dept: Zoning **Status:** Approved with Conditions **Reviewer:** Marge Schmuckal **Approval Date:** 11/01/2006

Note: **Ok to Issue:**

- 1) This permit is being approved on the basis of plans submitted. Any deviations shall require a separate approval before starting that work.
- 2) This property shall remain a a tavern on the first floor with office and 3 residential dwelling units in the rest of the building. Any change of use shall require a separate permit application for review and approval.
- 3) This is NOT an approval for an additional dwelling unit. You SHALL NOT add any additional kitchen equipment including, but not limited to items such as stoves, microwaves, refrigerators, or kitchen sinks, etc. Without special approvals.

Dept: Building **Status:** Approved with Conditions **Reviewer:** Michael A. Collins **Approval Date:** 11/03/2006

Note: **Ok to Issue:**

- 1) Maintain proper setback(s) from property lines/buildings and proper clearances from verticle openings when direct venting.
- 2) Equipment must be installed in compliance with the manufacturer's specifications
- 3) The installation must comply with the State of Maine Gas Regulations.

Dept: Fire **Status:** Approved with Conditions **Reviewer:** Cptn Greg Cass **Approval Date:** 11/02/2006

Note: **Ok to Issue:**

- 1) No unvented gas heating units
- 2) Install shall comply with NFPA 54.

PROPOSAL

1396

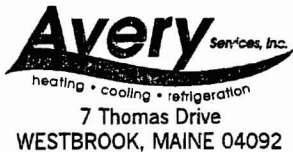

(207) 772-8687 DEPT. OF BUILDING INSPECTION
FAX (207) 874-0935 CITY OF PORTLAND, ME

TO: MAJE in Maine
223 Congress Street
Portland ME 04101



PHONE 609-517-4924	DATE 10/24/06
JOB NAME / LOCATION Central Heating & air conditioning. Bar system	
JOB NUMBER MSD	JOB PHONE

We hereby submit specifications and estimates for:

Avery Services, Inc. is pleased to submit a quote to perform the following work:

- Provide and install a Carrier 58MVB gas fired furnace with variable speed blower motor that uses 80% less electricity than a standard unit.
- Provide and install a Carrier 24APA3 Puron condensing unit.
- Provide and install a Carrier mechanical air cleaner.
- Provide and install a Carrier Thermidistat control.
- Provide and install refrigerant lines between the two components.
- Provide and install a galvanized ductwork system and ducted return, a spiral trunk with eight (8) supply diffusers, and one (1) wall mounted return grille.
- Provide and install a Rinnai Continuum 2532 commercial grade unit that water will reach ~~180 degrees~~.

OPTIONS:

- A) Substitute a Carrier 58MXB080-F16 with standard thermostat for the 58MVB furnace with Thermidistat. DEDUCT \$763.00 MS initials.
- B) Substitute a 24ABA342A003 condensing unit for the 24APA3 condensing unit. DEDUCT \$480.00 MS initials.

MSD deduct 1400 initial MS

EXCLUSIONS: Power wiring, structural, soffiting, carpentry, domestic plumbing

*Deduct \$1800 Total contract amount 23,000 MSD for Both systems
Nov 30 Job will be complete*

We Propose hereby to furnish material and labor complete in accordance with the above specifications, for the sum of:
Fifteen Thousand One Hundred Eighty Eight and 00/100 Dollars dollars (\$) 15,188.00

Payment to be made as follows:
\$3,797.00 upon acceptance - Progress billing/net 10 days - All balances due upon substantial completion.
If payment is not made as outlined above, a service charge of 2% per month on the overdue balance plus all reasonable costs of collection, including attorney's fees will be paid.

All material is guaranteed to be as specified. All work to be completed in a professional manner according to standard practices. Any alteration or deviation from above specifications involving extra costs will be executed only upon written orders, and will become an extra charge over and above the estimate. All agreements contingent upon strikes, accidents or delays beyond our control. Owner to carry fire, tornado, and other necessary insurance. Our workers are fully covered by Worker's Compensation insurance.

Authorized Signature *[Signature]* President

Note: This proposal may be withdrawn by us if not accepted within 30 days.

No promises, agreements or representations of any solicitor or employee of the seller shall be binding upon the seller unless made a part of this order in writing.

Acceptance of Proposal - The above prices, specifications and conditions are satisfactory and are hereby accepted. You are authorized to do the work as specified. Payment will be made as outlined above.

Signature *[Signature]*
Signature _____

Date of Acceptance: _____

PROPOSAL

1397

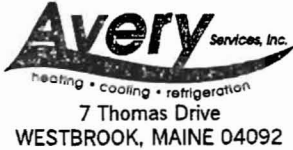

(207) 772-8687
FAX (207) 874-0933

TO: MAJE in Maine
223 Congress Street
Portland ME 04101

PHONE 609-517-4924	DATE 10/24/06
JOB NAME / LOCATION Central Heating & air conditioning. Furniture Store	
JOB NUMBER MSD	JOB PHONE

We hereby submit specifications and estimates for:

Avery Services, Inc. is pleased to submit a quote to perform the following work:

- Provide and install a Carrier 58MVB gas fired furnace with variable speed blower motor that uses 80% less electricity than a standard unit.
- Provide and install a Carrier 24APA3 Puron condensing unit.
- Provide and install a Carrier mechanical air cleaner.
- Provide and install a Carrier Thermidistat control.
- Provide and install refrigerant lines between the two components.
- Provide and install a galvanized ductwork system and ducted return, a spiral trunk with eight (8) supply diffusers, and one (1) wall mounted return grille.

OPTIONS:

- A) Substitute a Carrier 58MXB080-F120 furnace with standard thermostat for the 58MVB furnace with Thermidistat. DEDUCT \$856.00 MS initials.
- B) Substitute a 24ABA360A003 condensing unit for the 24APA3 condensing unit. DEDUCT \$585.00 MS initials.

EXCLUSIONS: Power wiring, structural, soffiting, carpentry, domestic plumbing.

We Propose hereby to furnish material and labor — complete in accordance with the above specifications, for the sum of:
Thirteen Thousand Five Hundred Forty Five and 00/100 Dollars dollars (\$) **13,545.00**).

Payment to be made as follows:

\$3,386.25 upon acceptance - Progress billing/net 10 days - All balances due upon substantial completion.

If payment is not made as outlined above, a service charge of 2% per month on the overdue balance plus all reasonable costs of collection including attorney's fees will be paid.

All material is guaranteed to be as specified. All work to be completed in a professional manner according to standard practices. Any alteration or deviation from above specifications involving extra costs will be executed only upon written orders, and will become an extra charge over and above the estimate. All agreements contingent upon strikes, accidents or delays beyond our control. Owner to carry fire, tornado, and other necessary insurance. Our workers are fully covered by Worker's Compensation insurance.

Authorized Signature

[Handwritten Signature]
Note: This proposal may be withdrawn by us if not accepted within 30 days.

No promises, agreements or representations of any solicitor or employee of the seller shall be binding upon the seller unless made a part of this order in writing.

Acceptance of Proposal — The above prices, specifications and conditions are satisfactory and are hereby accepted. You are authorized to do the work as specified. Payment will be made as outlined above.

Signature

[Handwritten Signature]

Signature

Date of Acceptance: _____

**CAPVP
Performance™ Series
Puron® Cased A-Coil**



Carrier Corporation • Syracuse, NY 13221
SUBJECT TO CHANGE WITHOUT NOTICE

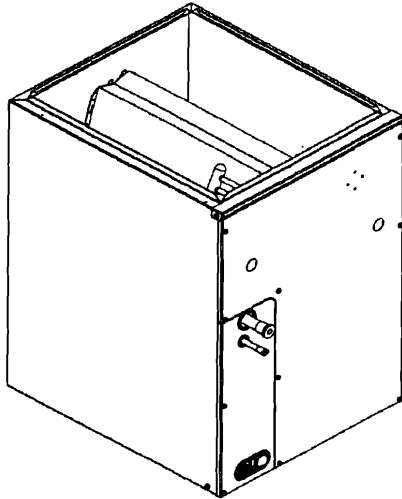

STANDARD FEATURES

- Purred-refrigerant compatible
- Factory-installed Purred TXV
- Both upflow and downflow applications with one SKU
- Completely new A-coil design
- Painted cabinets to match taupe metallic furnace color
- Sturdy 22-gauge cabinets
- High-tech fin technology
- New technology FRTP - sloped - drain pan
- Split-delta plates
- Grooved copper tubing
- Foil-faced insulation
- UV light knockouts in cabinets - from the factory
- Industry exclusive tin-plated copper coils available
- Cabinets meet 2% air leakage
- Non-sweat cabinets at extreme conditions
- One size screw, same as on furnaces
- Easy slide out coils for inspection/replacement
- Easy inspection and coil cleaning from front of unit

**Performance
SERIES**

LIMITED WARRANTY

- 5-year warranty on all parts



CERTIFICATION APPLIES ONLY WHEN
THE COMPLETE SYSTEM IS LISTED
WITH ARI

OPTIONAL EXTENDED WARRANTIES	NET PRICE
Labor Only – 2nd through 5th year	<i>See Optional</i>
Parts and Labor – 6th through 10th year (requires 2nd through 5th year labor)	<i>Warranty</i>
Parts Only – 6th year through 10th year*	<i>Price Section</i>

*Purchase within 5 years from date of installation.

ODS CATALOG ORDERING NO.	TONS	DIMENSIONS (IN.)			APPROX SHIP WT (LB)
		HEIGHT	WIDTH	DEPTH	
CAPVP1814ACA	1.5	18-5/16	14-3/16	20-5/8	34.5
CAPVP2414ACA	2	19-9/16	14-3/16	20-5/8	38
CAPVP2417ACA	2	19-9/16	17-1/2	20-5/8	40.5
CAPVP3014ACA	2.5	23-11/16	14-3/16	20-5/8	48
CAPVP3017ACA	2.5	23-11/16	17-1/2	20-5/8	51.5
CAPVP3614ACA	3	25-7/8	14-3/16	20-5/8	51
CAPVP3617ACA	3	25-7/8	17-1/2	20-5/8	55
CAPVP3621ACA	3	25-7/8	21	20-5/8	59
CAPVP4221ACA	3.5	27-9/16	21	20-5/8	64.5
CAPVP4224ACA	3.5	27-9/16	24-1/2	20-5/8	69
CAPVP4817ACA	4	33-7/8	17-1/2	20-5/8	79
CAPVP4821ACA	4	27-9/16	21	20-5/8	72
CAPVP4824ACA	4	27-9/16	24-1/2	20-5/8	76.5
CAPVP6021ACA	5	33-7/8	21	20-5/8	83
CAPVP6024ACA	5	33-7/8	24-1/2	20-5/8	87.5
CAPVP1814ATA	1.5	18-5/16	14-3/16	20-5/8	37.5
CAPVP2414ATA	2	19-9/16	14-3/16	20-5/8	41
CAPVP2417ATA	2	19-9/16	17-1/2	20-5/8	44
CAPVP3014ATA	2.5	23-11/16	14-3/16	20-5/8	50.5
CAPVP3017ATA	2.5	23-11/16	17-1/2	20-5/8	53.5
CAPVP3614ATA	3	25-7/8	14-3/16	20-5/8	54
CAPVP3617ATA	3	25-7/8	17-1/2	20-5/8	57.5
CAPVP3621ATA	3	25-7/8	21	20-5/8	61
CAPVP4221ATA	3.5	27-9/16	21	20-5/8	67.5
CAPVP4224ATA	3.5	27-9/16	24-1/2	20-5/8	72
CAPVP4817ATA	4	33-7/8	17-1/2	20-5/8	81.5
CAPVP4821ATA	4	27-9/16	21	20-5/8	74.5
CAPVP4824ATA	4	27-9/16	24-1/2	20-5/8	79
CAPVP6021ATA	5	33-7/8	21	20-5/8	86
CAPVP6024ATA	5	33-7/8	24-1/2	20-5/8	90.5

www.Key.com/KeyProcure

BAP

www.Key.com/KeyProcure

Furniture Store

See current Product Data Digest for SEER and system capacity.
The 11th position C=copper, T=tin-plated.



58MXB

Carrier Corporation • Syracuse, NY 13221

ODS CATALOG ORDERING NO.*	RATED HEATING OUTPUT (BTUH)†	HEATING		COOLING CFM @ 0.5 ESP‡	MOTOR HP-SPEED (VARIABLE SPEED)	MEDIA CABINET SUPPLIED (IN.)	APPROX SHIP. WT (LB)	NET PRICE
		CFM	ESP					
58MXB040-F-1--08	38,000	850	0.10	895	1/5-3	16	174	www.KeyProcure.com BMS System Furniture Store
58MXB040-F-1--12	38,000	1125	0.10	1215	1/3-4	16	175	
58MXB060-F-1--08	56,000	885	0.12	900	1/5-3	16	180	
58MXB060-F-1--12	56,000	1065	0.12	1200	1/3-4	16	182	
58MXB060-F-1--16	56,000	1320	0.12	1545	1/2-4	16	183	
58MXB080-F-1--12	74,000	1190	0.15	1245	1/3-4	16	198	
58MXB080-F-1--16	75,000	1285	0.15	1525	1/2-4	16	205	
58MXB080-F-1--20	75,000	1785	0.15	1925**/2035)††	3/4-4	20	214	
58MXB100-F-1--16	93,000	1315	0.20	1570	1/2-4	20	229	
58MXB100-F-1--20	93,000	1690	0.20	1930**/2130)††	3/4-4	20	232	
58MXB120-F-1--20	112,000	1720	0.20	2000**/2130)††	3/4-4	24	261	
58MXB140-F-1--20	128,000	1970	0.20	1990**/2045)††	3/4-4	24	261	

* 08 designates 800 air model. 12 designates 1200 CFM air model. 20 designates 2000 CFM air model.

† Capacity in accordance with DOE test procedures. Ratings are position dependent. See rating plate.

‡ Airflow shown is for bottom only return-air supply. For air delivery above 1800 CFM, see Air Delivery table – in Product Data Digest – for other options.

** Data shown is for bottom only return-air supply.

†† Data shown is for both sides or 1 side and bottom return-air supply.

ESP - External Static Pressure

	NET PRICE
OPTIONAL EXTENDED WARRANTIES	
Labor Only - 2nd through 5th yr	
Parts and Labor - 6th through 10th year (requires 2nd through 5th year labor)	See Optional Warranties
Parts Only (Excludes heat exchanger) - 6th through 10th year	
covered under the above warranties at NO ADDITIONAL CHARGE when included with registration.	Price Section
Heat Exchanger Parts Only - through 20th year	
Purchase within 5 yrs from date of installation	

**24ABA4
Base 14
Air Conditioner with Puron®**



SUBJECT TO CHANGE WITHOUT NOTICE

Not stocked locally - factory orders only

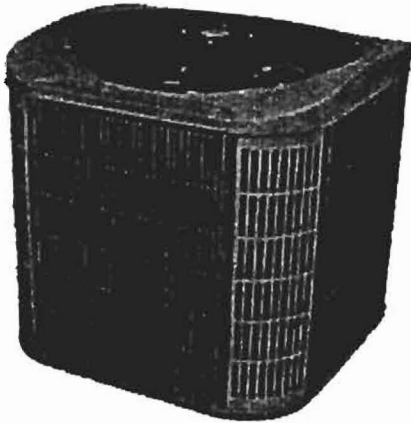

Carrier Base 14 Air Conditioner with Puron Refrigerant, Model 24ABA4, is available in 1.5-5 ton nominal-sized units.

STANDARD FEATURES

Energy Efficiency

- 14 SEER / 11-12 EER

Sound

- Sound as low as 76 dBA

Reliability, Quality and Durability

- Scroll Compressor
- Field-installed Filter Drier
- Front-seating Service Valves
- Internal Pressure-Relief Valve
- Internal thermal overload
- Baked-on powder paint
- Dense wire Coil Guard standard

LIMITED WARRANTY

- Standard limited warranty: 5 year on parts and 5 year warranty on compressor



ODS CATALOG ORDERING NO.	NOMINAL COOLING SIZE (Btu x 1,000)	VOLTS-PHASE (60 HZ)	OPERATING VOLTAGE RANGE	PACKAGED DIMENSIONS (IN.) D X W X H†	APPROX SHIP WT (LB)†
24ABA418A003	18	208-230-1	197-253	32 X 32 X 39	197
24ABA424A003	24			32 X 32 X 46	214
24ABA430A003	30			32 X 32 X 46	217
24ABA436A003	36			36 X 36 X 39	225
24ABA442A003	42			36 X 36 X 50	272
24ABA448A003	48			36 X 36 X 36	272
24ABA460A003	60			36 X 36 X 50	330

* All units are individually skidded for shipment.

† Weight and height may vary by series. See PD for actual weights and dimensions by series. Height shown is maximum.

www.Key.com/KeyProcure

DAE Furniture Store

Appx wieght on spiral
325lbs EH system

Notes
Both level
ground

- Bar System
- 58MXB080-F-1-16
- Coil CARP422HACA
- Coil 24ABA342A003

- Furniture Store
- 58MXB080-F-1-20
- Coil CARP6024ACA
- Coil 24ABA360A003

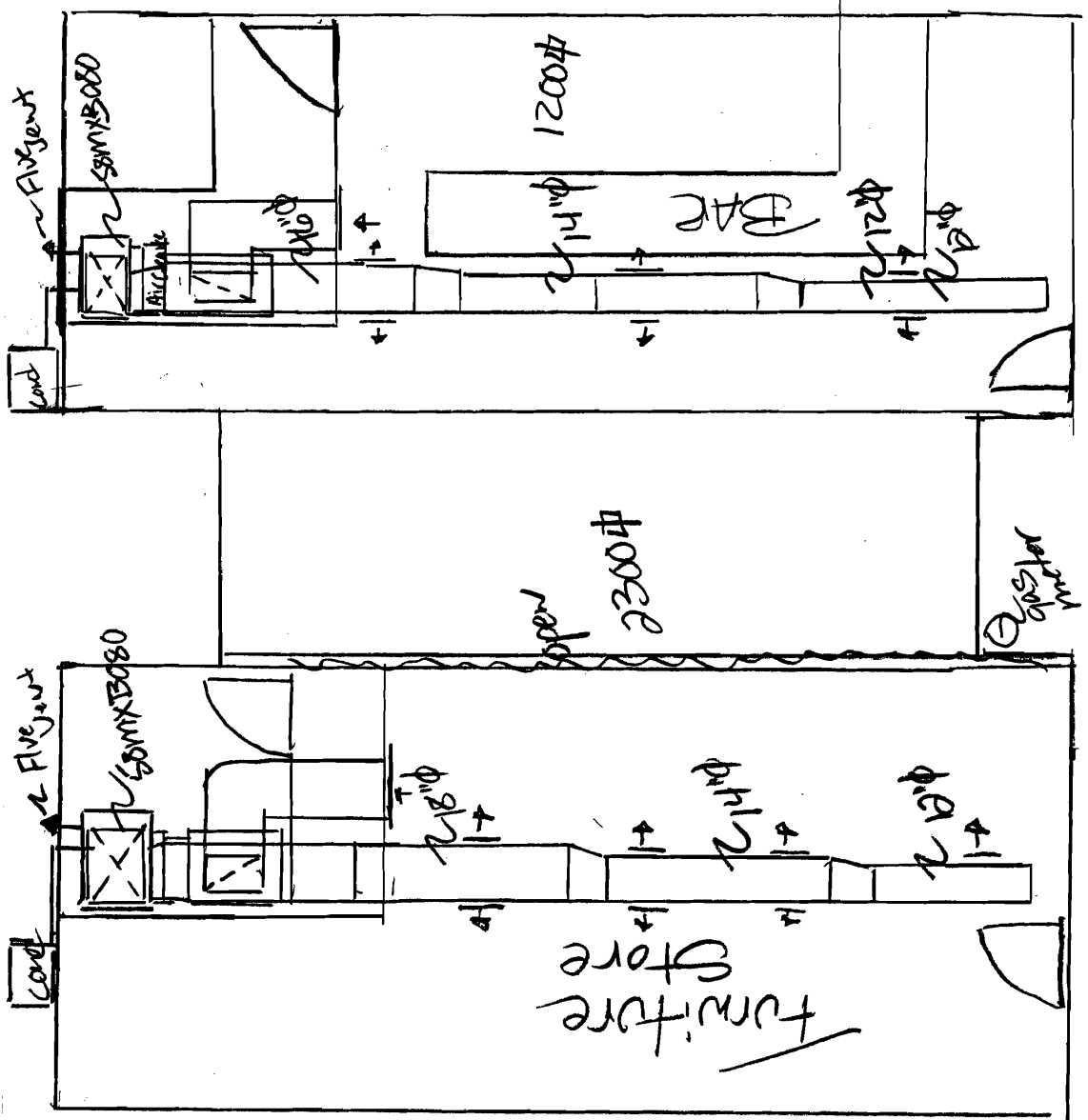

WASH AVE

Congress