

(1) GENERAL NOTES:

- A. FIRE ALARM SYSTEM WIRING SHALL COMPLY WITH THE NATIONAL ELECTRICAL CODE, APPLICABLE STATE AND LOCAL CODES, AND SHALL BE COORDINATED WITH THE LOCAL AUTHORITY HAVING JURISDICTION.
- B. CAUTION: DO NOT CONNECT ANY POWER TO THE CONTROL PANEL (BATTERIES OR 120V AC) UNTIL ALL OTHER FIELD WIRING IS TESTED AND CONNECTED.
- C. DO NOT INSTALL FIRE ALARM CONTROL PANEL, NAC POWER SUPPLY PANEL, SMOKE DETECTORS OR ANY ADDRESSABLE DEVICES IN UNHEATED SPACES.
- D. DO NOT INSTALL ANY AC CURRENT-CARRYING CONDUCTORS CLOSE TO OR IN THE SAME RACEWAY WITH FIRE ALARM SYSTEM CONDUCTORS.
- E. SOLID LINES REPRESENT CONNECTIONS TO BE MADE BY THE SYSTEM INSTALLER.
- F. ALL RELAYS ARE SHOWN IN NORMAL SUPERVISORY CONDITION. ALL RELAYS ARE FORM "C" TYPE.

(2) INSTALLATION NOTES

- A. SMOKE DETECTORS SHALL NOT BE MOUNTED ANY CLOSER THAN 3' FROM ANY AIR DUCT OPENINGS
- B. ELEVATOR LOBBY SMOKE DETECTORS SHALL BE MOUNTED WITHIN 10' OF THE ELEVATOR DOOR
- C. MANUAL PULL STATIONS SHALL BE MOUNTED PER ADA REQUIREMENTS: 48" AFF OR 42" AFF TO COMPLY WITH SIDE/FRONT REACH REQUIREMENTS
- D. WALL MOUNTED HORN/STROBES & STROBES SHALL BE MOUNTED 6" FROM CEILING, OR 96" TO 80" AFF TO THE CENTER OF STROBE
- E. HORN/STROBES & STROBES SHALL BE MOUNTED 15' FROM THE CORNER OF THE WALL. IF THIS IS NOT POSSIBLE, DEVICE SHALL BE CENTERED ON THAT WALL.
- F. CEILING MOUNTED HALLWAY DEVICES SHALL BE LOCATED IN A SYMMETRICAL MANNER DOWN CENTER OF HALLWAY WHEN POSSIBLE.
- G. MONITORING REQUIRES TWO FAIRPOINT PHONE LINES UNLESS OTHER ARRANGEMENTS HAVE BEEN MADE.

- (3) SEE INITIATION CIRCUITS AND NAC CIRCUITS FOR INTEGRATION OF BOTH SLC AND NAC CIRCUITS
- (4) ALL CABLING IS 14/2 FOR THE NAC CIRCUITS UNLESS OTHERWISE SHOWN
- (5) ALL CABLING IS 16/2 FOR THE SLC CIRCUITS UNLESS OTHERWISE SHOWN
- (6)

- AC = ALARM CONTROL MODULE
- R = ARM = ADDRESSABLE RELAY MODULE
- AV = AUDIO VISUAL DEVICE
(SET TO 15cd UNLESS NOTED OTHERWISE)
- B = EXTERIOR BEACON
- CO = CO DETECTOR
- D = DUAL MODULE
- DUCT=DUCT DETECTOR
- F = FLOW
- FACP = MAIN FIRE PANEL
- H = HEAT DETECTOR
- I = ISOLATION MODULES
- T.S. = TWISTED SHIELDED
- S/CO = SMOKE/CO DETECTOR
- RL = REMOTE LIGHT
- K = KNOX BOX
- LA = LOW AIR
- MM = MINI MODULE
- P = PULL STATION
- PS = PRESSURE SWITCH
- RI = REMOTE INDICATOR
- S = SMOKE
- SA = SMOKE WITH AUDIBLE BASE
- T = TAMPER
- TS = TEST SWITCH
- V = VISUAL DEVICE ONLY
(SET TO 15cd UNLESS NOTED OTHERWISE)
- MH = MINI HORN
- RTS = REMOTE TEST MODULE
- PS = PULL STATION
- CL = CORRIDOR LIGHT
- CO = CO DETECTOR (MAY REQUIRES 24 VDC POWER)
- SCM = INPUT MODULE

= FIRE EXTINGUISHER MONITORING



Reviewed for Code Compliance
Permitting and Inspections Department
Approved with Conditions
02/12/2020

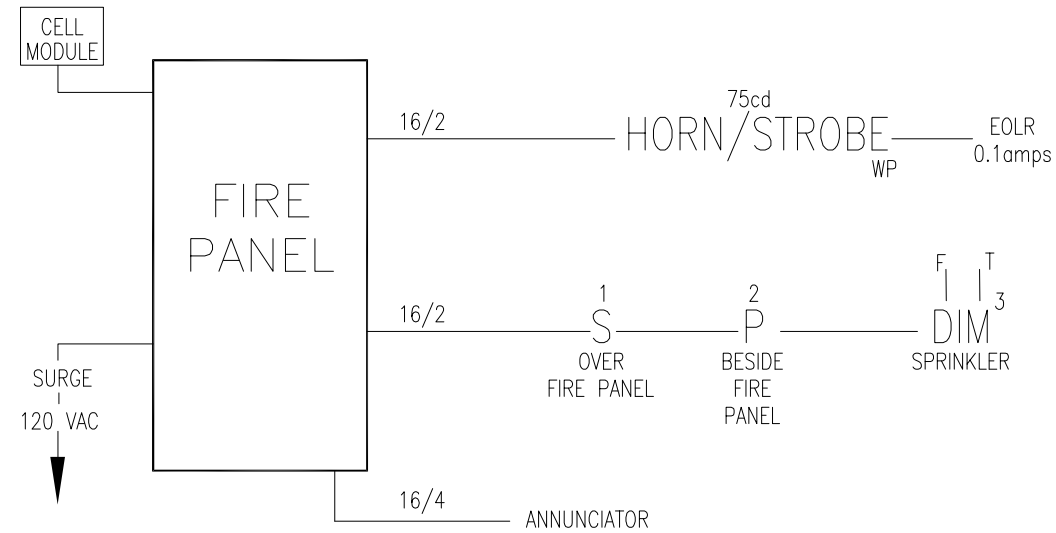

CONSULTANT: Rich Brobst JR.

 320 PRESUMPSCOT ST. UNIT#2
 PORTLAND, MAINE 04103
 Phone: (207) 536-4800
 Cell: (207) 699-6800

PROJECT:
35 OXFORD STREET
 Portland, MAINE

DRAWING:
RISER

REVISIONS

DATE: 02/03/2020

SCALE: NTS

DRAWN BY: SSA

APPROVED BY: -

SHEET:
1



Guardian Systems of Maine
 320 Presumpscot St., Unit #2
 Portland, ME 04103
 207-536-4800 office

35 Oxford Street Device List

| Quantity | Item | Description |
|----------|--------------|---|
| 1 | IPA-60 | Fire panel, 60 points, 2 NACs, 5 amps, 2 I/O circuits |
| 2 | Bat 12-7 | Battery 12 volts, 7 amp/hours |
| 1 | UD-2000 | Dact for Potter panels |
| 1 | E120V-GT | Space Age 120 VAC surge protector and breaker label |
| 1 | RA-6500R | Annunciator |
| 1 | PAD-100-PHD | Addressable smoke/heat detector |
| 1 | PAD-100-6B | Detector base |
| 1 | PAD-100-DIM | Dual input |
| 1 | SSU00673 | Space Age Fire Document cabinet |
| 1 | PAD-100-PSDA | Addressable dual action pull station |
| 1 | HS-24WR-WP | Horn/strobe, red, weatherproof |
| 1 | | Key box 3261 |



Reviewed for Code Compliance
 Permitting and Inspections Department
 Approved with Conditions

02/12/2020

Features

- Single module with dual contact monitoring inputs
- Two (2) Class B or one (1) Class A monitoring inputs
- SLC Class A, Class X & Class B
- Mounts in a standard 4" or double gang box
- Wiring terminals accessible when mounted in box
- All wiring terminals accept 22 to 12 AWG
- Product includes a 5 year warranty

NOTE: This addressable module does not support 2-wire smoke detectors.



Description

The PAD100-DIM uses one (1) SLC loop address when monitoring two (2) Class B circuits or one (1) Class A circuit. The module mounts on either a 4" square or double gang box. The module is capable of monitoring two (2) separate class B circuits making it ideal for monitoring sprinkler waterflow and valve tamper switches when they are located in the same proximity. The PAD100-DIM includes one red LED to indicate the module's status. In normal condition, the LED flashes when the device is being polled by the control panel. When an input is activated, the LED will flash at a fast rate.

Application

The PAD100-DIM is compatible with Potter's IPA series addressable fire alarm control panels. The PAD100-DIM is an interface module used to monitor dry contact devices such as sprinkler waterflow, valve tamper switches, or conventional pull stations. The module is capable of monitoring two separate Class B or one Class A circuits.

Setting the Address

Each addressable SLC device must be assigned an address. The address is set using the DIP switch located on the PAD100-DIM. When the PAD100-DIM is used to monitor two individual Class B circuits a single device address is assigned, each input is then identified as a sub-point of the module address. For example, if the address number is assigned as "8", the first input will be "8.1" and the second input will be "8.2".

Before connecting a device to the SLC loop, take the following precautions to prevent potential damage to the panel or device:

1. Power to the device is removed.
2. Field wiring is correctly installed.
3. Field wiring has no open or short circuits.

Technical Specifications

| | |
|-------------------------------|---|
| Operating Voltage | 24.0V |
| Max SLC Standby Current | 240 μ A |
| Max SLC Alarm Current | 240 μ A |
| Max Wiring Resistance of IDC | 100 Ω |
| Max Wiring Capacitance of IDC | 1 μ F |
| EOL Resistor | 5.1K Ω |
| Operating Temperature Range | 32 to 120°F (0 to 49°C) |
| Operating Humidity Range | 0 to 93% (non-condensing) |
| Max no. of Module Per Loop | 127 units |
| Dimensions | 4.17" (106mm)L \times 4.17" (106mm)W \times 1.14" (29mm)D |
| Mounting Options | Standard 4" Square or Double Gang Box |
| Shipping Weight | 0.6 lbs |



Reviewed for Code Compliance
Permitting and Inspections Department
Approved with Conditions

02/12/2020

Installation Using Compatible Electrical Box

Fig 1

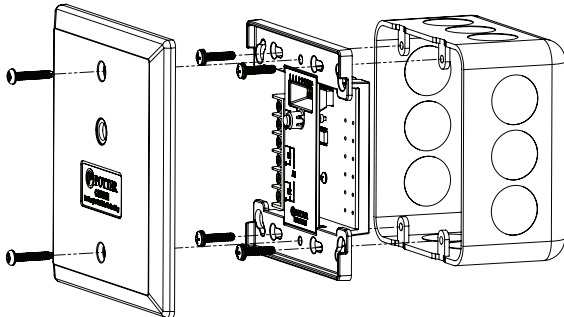

Wiring Diagrams

PAD100-DIM With One Class A Circuit

Fig 2

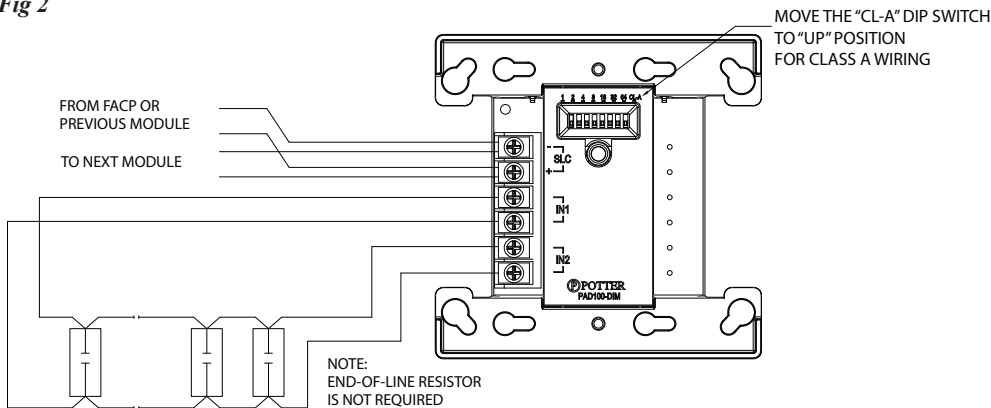

PAD100-DIM With Two Class B Circuits

Fig 3

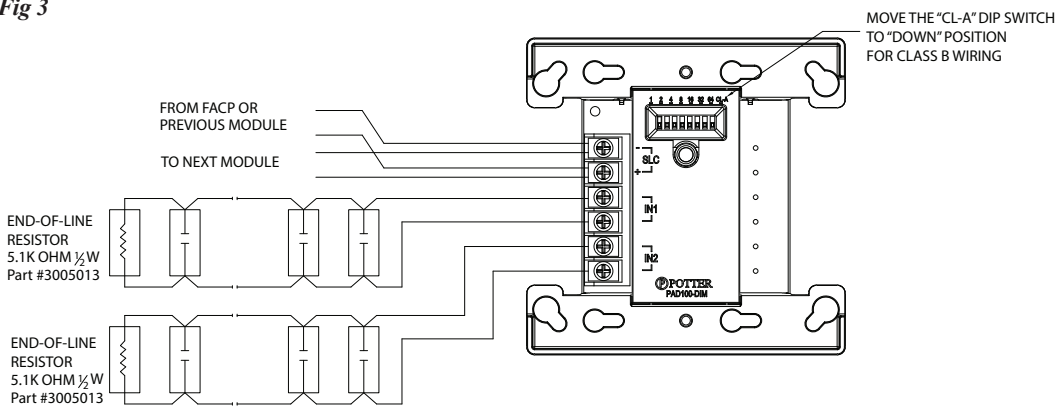

Ordering Information

| Model | Description | Stock No. |
|------------|-------------------|-----------|
| PAD100-DIM | Dual Input Module | 3992703 |



Reviewed for Code Compliance
Permitting and Inspections Department
Approved with Conditions

02/12/2020

Features

- Single or Dual Action versions
- Durable die-cast construction
- Reset key matches the fire alarm control panels
- Compatible with IPA Series panels
- SLC Class A, Class X & Class B
- Product includes a 5 year warranty



Description

The PAD100-PSSA (Single Action) is activated by simply pulling the white “T” bar handle down. The PAD100-PSDA (Dual Action) is activated by lifting the front cover and then pulling the white “T” bar handle down. Once activated, the “T” bar cannot be reset without opening the front cover. Opening the front cover will also activate the pull station. To reset the PAD100-PS Series, use the Potter WS-93 key to unlock and open the front cover. Once the cover is open, push the “T” bar back into the normal position and re-secure the front cover.

Application

The PAD100-PSSA/PSDA is compatible with Potter’s IPA series addressable fire alarm control panels. It is a non-coded addressable pull station available in either a single or dual action model and installs on a single gang box or surface mounts using the P32-BB or P32-DBB (deep) back box.

Technical Specifications

| | |
|---------------------------|--|
| Operating Voltage | 24.0 VDC |
| Max SLC Standby Current | 200uA |
| Max SLC Alarm Current | 200uA |
| Environmental Limitations | 32°F - 120°F (0° - 49°C) Indoor Only |
| Dimensions | 4.75” H x 3.25” W x 1.75” D |
| Relative Humidity Range | 0 - 93% (non-condensing) |
| Mounting Options | Single gang box or Potter P32-BB/DBB |
| Shipping Weight | APS-SA - 1.22 lbs. APS-DA - 1.46 lbs. |



Reviewed for Code Compliance
Permitting and Inspections Department
Approved with Conditions

02/12/2020

Setting the Address

The PAD100-PS Series uses one SLC address assigned to the device. The address is set using the DIP switch located on the back of the PAD100-PS device.

Pull Station Front View
Fig 1

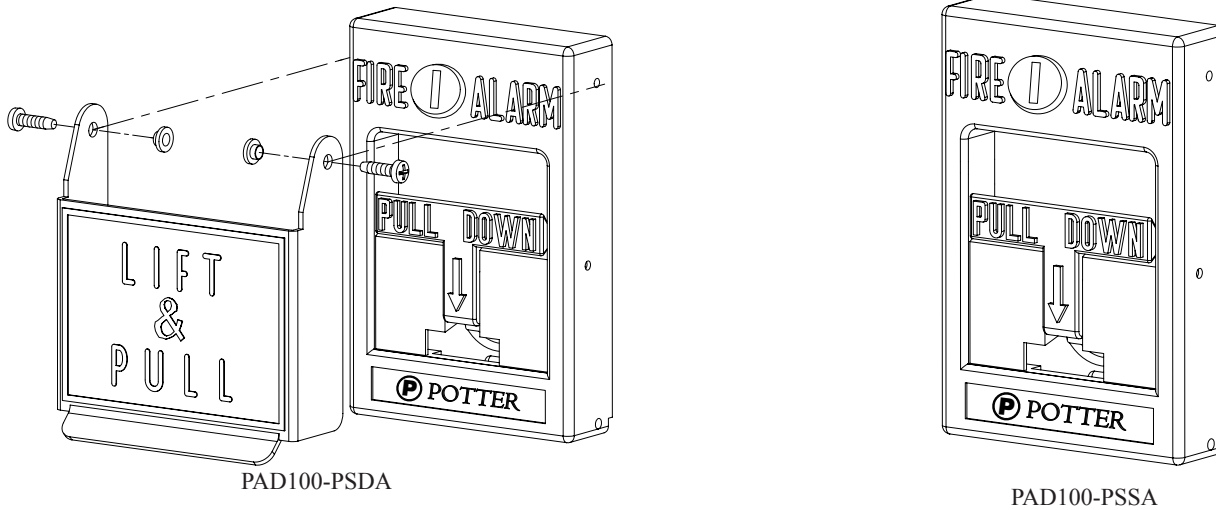

Pull Station Back View and Wiring
Fig 2

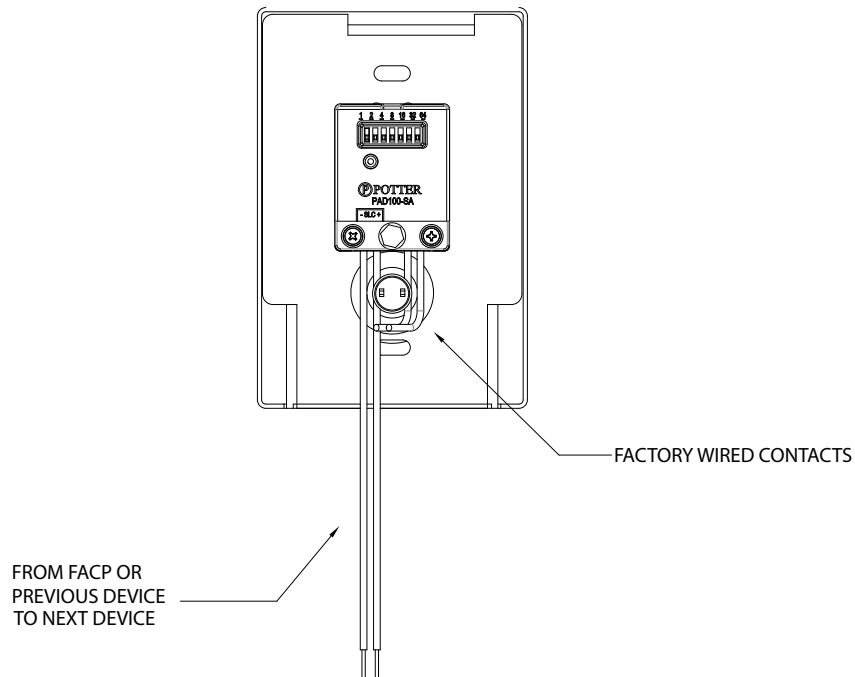

Ordering Information

| Model | Description | Stock No. |
|-------------|---|-----------|
| PAD100-PSSA | Addressable Pull Station, Single Action | 3992721 |
| PAD100-PSDA | Addressable Pull Station, Dual Action | 3992720 |



Reviewed for Code Compliance
Permitting and Inspections Department
Approved with Conditions

02/12/2020

Features

- 60 addresses available on this analog addressable system
- Additional system capacity achieved via multi-point SLC modules
- 99 software zones
- NFPA 72 Compliant Smoke Sensitivity Test Built-In
- System Operates as Class A or Class B for SLC, P-Link and NACs
- 5 Amp Power Supply, Expandable to 310 amps
- 2 NACS, Regulated, Rated at 3 Amps each, expandable to 188
- 2 Input/Output (I/O) Circuits for system flexibility rated at 1 Amp each, ideal for manual release and abort
- Strobe Synchronization and System Wide Sync for Potter/AMSECO®, Gentex®, Cooper Wheelock® and System Sensor® strobes
- Dedicated Alarm, Supervisory and Trouble Relays
- 4,000 Event History Buffer
- Cabinet will house up to 18 AH batteries
- Optional two line DACT with UD-1000 that can report General, Zone or Point Information
- Built in IP Communicator
- Ethernet Port for Programming and Network Connectivity
- E-Mail System Status, Reports and Event Information
- Product includes 5 year warranty



Reviewed for Code Compliance
Permitting and Inspections Department
Approved with Conditions
02/12/2020



Description

The IPA-60 is an analog/addressable releasing fire alarm system with a total system capacity of 60 addresses. Additional capacity on the system is achieved using multi-point SLC modules. The control panel utilizes the exclusive Potter protocol that includes a complete line of sensors and modules. Each SLC may be comprised of any combination of smoke sensor, heat detectors or modules and allows for a total of 50 ohms of impedance and may use any wire compliant with the National Electrical Code (NEC).

The IPA-60 has a 5 Amp power supply with two Notification Appliance Circuits (NACs) and two Input/Output (I/O) circuits. The NACs are rated at 3 Amps each and the I/Os are rated at 1 Amp each. Each output is regulated and power limited. In addition, each output is uniquely programmable and may be configured for steady signal, strobe synchronization, constant power, door holder power, or releasing. The strobe synchronization includes Potter/AMSECO, Gentex, System Sensor and Cooper/Wheelock and with the exclusive Quadrasync each output may have a unique brand and all strobes will flash together. The I/Os are designed for inputs such as manual release stations and abort switches that will not require polling and react nearly instantaneously.

The IPA-60 is listed for releasing of fire suppression systems. The software allows cross zones, counting zones, and timers for suppression. The system is capable of multiple release outputs across multiple hazards. In addition, the PSN-1000 may be used to extend releasing capability. The NACs may be expanded using the PSN-1000 series intelligent power supplies. Each PSN-1000 adds another 10 Amps of power, 2 additional input circuits and the IPA-60 will support up to 31 power supplies. The system will synchronize the strobes system wide. In addition, the PSN-1000E has space to allow the installation of up to six expansion cards. The cards mount on a stacker bracket that allows access to all SLC circuit connections.

Technical Specifications

| | |
|--------------------------------|---|
| Dimensions | 16"W x 17"H x 3 7/8"D |
| AC Mains | 3.0 Amps @ 120 VAC 50/60 HZ 2.0 Amps @ 240 VAC 50/60 HZ |
| Enclosure | 16 gauge cold rolled steel with removable locked door with Lexan viewing window |
| Battery | Standby Current-130 mA Alarm Current-200 mA <ul style="list-style-type: none"> • 5 Amps power for NACs, I/O, and P-Link • 3 Amps per NAC, regulated • 1 Amp per I/O circuit, regulated • Battery Charger range 8-55 Ah • Battery Charger voltage 27.3 VDC • P-Link maximum current of 1 Amp |
| Temperature and Humidity Range | 32° to 120° (0°C to 49°C) with a maximum humidity of 93% non-condensing. |
| Standards | <ul style="list-style-type: none"> • NFPA 12, 12A, 13, 15, 16, 17, 17A, 70, 72, 750, and 2001 • ANSI/UL 864 - Local (L), Remote Station (RS), Central Station (CS), Propriety (PPU), Auxiliary (AUX). Type of Service: Automatic (A), Manual (M), Water flow (WF) Sprinkler Supervisory (SS) Type of Signaling: Digital Alarm Communicator (DAC), March Time (March), Non Coded (NC), Reverse Polarity (Rev Pol), Other Technologies (OT) • IBC 2000, 2003, 2006, 2009, 2012 |

SLC Loop Accessories

The control panel may be connected with up to 60 addressable devices or modules in any combination. The SLC is not restricted by any special wire requirements and may be wired with any wire that complies with the NEC.

SLC Loop Devices

| Device | Description |
|--------------|---|
| PAD100-PD | Analog Photo Electric Smoke Detector is a smoke detector with a listed obscuration of 1.02 to 3.83 percent per foot. |
| PAD100-PHD | Combination Analog Photo Electric Smoke/Heat Detector – a smoke detector with a listed obscuration of 1.02 to 3.83 percent obscuration and a fixed temperature 135° Fahrenheit heat detector. |
| PAD100-HD | Analog Fixed Temperature Heat Detector that is selectable from 135° F to 185°F. |
| PAD100-DUCTR | Addressable Duct Smoke Detector with Form C Relay. |
| PAD100-DUCT | Addressable Duct Smoke Detector. |
| PAD100-6B | 6” round base that is mounted to an electrical box and wired for connection of one of the above sensors. |
| PAD100-4B | 4” round base that may be mounted to an electrical box and wired for connection to the above sensors. |
| PAD100-IB | Isolator base that interrupts a short in a SLC and prevents the short from affecting protected devices on the loop. |
| PAD100-RB | Addressable Relay Base that contains one relay controlled by the SLC. Relay is rated at rated at 2 amps at 30 VDC or 0.5A at 125VAC. |
| PAD100-SB | Addressable Sounder Base that contains an addressable sounder module that may be configured for local, group and all call. |
| PAD100-CD | Addressable CO gas detector. |
| PAD100-DD | Addressable photo electric smoke detector for use in DUCT/DUCTR enclosure. |

Modules

| Device | Description |
|-------------|---|
| PAD100-MIM | Micro Input Module provides a small foot print contact module for mounting inside an enclosure. |
| PAD100-PSSA | Single Action Addressable Pull Station. |
| PAD100-PSDA | Dual Action Addressable Pull Station. |
| PAD100-SIM | Single Input Module is a standard contact module with an LED that mounts into a 4” square electrical box. |
| PAD100-DIM | Dual Input Module is a device that can monitor two distinct inputs with a single device or in a Class A mode. |
| PAD100-TRTI | Two Relay Two Input module provides two form C relays that are individually controlled by the control panel. Each relay is rated for 2 amps at 30VDC or 0.5 amps at 125VAC. Also provides two contact inputs. |
| PAD100-NAC | Notification Appliance Circuit module is an addressable remote appliance circuit controlled by the panel. |
| PAD100-ZM | Zone Module is used to connect conventional 2-wire smoke detectors to the system. |
| PAD100-IM | Isolater Module interrupts a short on the SLC and prevents the short from affecting protected devices on the loop. |
| PAD100-RM | Relay Module that provides one form C relay controlled by the control panel. Relay is rated for 2 amps at 30VDC or 0.5 amps at 125VAC. |
| PAD100-LED | Module provides a single addressable LED that is controlled by the control panel. |
| PAD100-SM | Speaker Module provides switching for two audio channels. |
| PAD100-LEDK | Addressable LED and key switch that mounts in a single gang box. |
| PAD100-DRTS | DUCTR Remote Test Switch that mounts in a single gang box and optionally supervised. |
| PAD100-OROI | One Relay One Input Module provides one form C relay and one input. The relay is rated at 2 amps at 30VDC or 0.5 amps at 125VAC. |

SLC Features

The Potter protocol is a digital protocol with a proven design for reliability and noise immunity. The system does not require special cable or conductors for connection of the Signaling Line Circuit as long as the cable is compliant with NFPA 70 and NFPA 72. The system allows for Class A or Class B installations as well as “T-Taps”, with a max wiring distance of 10,000 Ft.

Sensor Features

The sensors through the fire alarm control panel provide a real time status as to the condition of the system. The smoke detector sensitivity, heat detector temperature level and drift compensation are all programmable options. The system also allows for a day/night mode where the panel automatically adjusts the sensitivity depending on the time of day. To assist in the reduction of false alarms, the smoke detectors also have a maintenance warning that sends a trouble signal when a detector is dirty to the point that it can no longer maintain the programmed sensitivity.

User Interface

The fire alarm control panel has a 2 x 16 LCD display to provide information to the system status. The keypad has navigation keys to allow manipulation of the Menu on board the panel. The panel is shipped standard with the following LEDs:

- AC Power - Green
- Alarm - Red
- Earth Fault - Amber
- Supervisory - Amber
- Silenced - Amber
- Trouble - Amber
- Pre-Release - Amber
- Release - Red

The common buttons include a Silence, Reset, Acknowledge, and Drill. All of the buttons are accessible once the locked door is opened.

P-Link

The IPA-60 has a proprietary communication protocol that communicates through a RS-485 connection to field devices. Up to 64 devices may be connected to a single P-Link connection. The P-Link includes the communication terminals and regulated 24 VDC connection for the field devices. The field devices may be any of the following:

PAD100-SLCE-Analog/Addressable loop expansion module

RA-6075R – 2 x 16 LCD annunciator with a key pad in a locked metal enclosure.

RA-6500R(F) – 4 x 40 LCD annunciator with a key pad in a locked metal enclosure. Flush mount version available.

LED-16(F) – 16 LED annunciator with common indicators in a locked metal enclosure. Flush mount version available.

PSN-1000(E) – 10 amp, remote intelligent power supply with 6 NACs, 2 I/Os and a P-Link repeater. This panel is listed in conjunction with the IPA-60 as releasing circuits.

CA-6500 – Class A convertor that converts the SLC, NACs and P-Link connection

UD-1000 – UL listed, Dual line telephone alarm communicator

DRV-50 – LED driver expander, used to connect up to 50 LEDs in a graphic display

FCB-1000 – Fire communication bridge, provides remote mounting of the Ethernet connection

FIB-1000 – Fiber interface module, used to extend P-Link to multi-mode fiber (2 required)

RLY-5 – Relay module, provides 5 form C relay contacts rated at 3.0 amps 24VDC/125AC

SPG-1000 – Serial parallel gateway, allows for the connection to a serial or parallel printer

The **FIB-1000**, **FCB-1000** and the **SPG-1000** may be installed in the stacker bracket or ordered with the optional rack mount enclosure.

MC-1000 Multi-Connect allows up to sixty-three IPA series panels to share a single reporting technology.

AE-2 – Two card expansion cabinet

AE-8 – Eight card expansion cabinet

AE-14 – Fourteen card expansion cabinet

Ethernet/I.P. Connection

The IPA-60 is shipped standard with an Ethernet connection.

This connection is the programming port and may be connected to a building Wide Area Network (WAN) or Local Area Network (LAN). Once connected to the Internet, the panel may be selectively programmed to e-mail alarm conditions, trouble conditions, supervisory conditions, test, Event History and detector status. An e-mail may be sent to the panel and the panel will e-mail the event history, detector status, configuration file or server status to an authorized E-mail account. In addition, reminders may be set to send an e-mail for service, testing or other conditions.

In addition, the Ethernet connection is UL listed as an IP communicator. The IP communicator is listed to report to the UL listed Sur-Gard III IP receiver. The IP communicator replaces the traditional less reliable alarm communicator transmitter that utilized telephone lines. The IP communicator is an active method of connection and communication to the monitoring station.

Dimensions

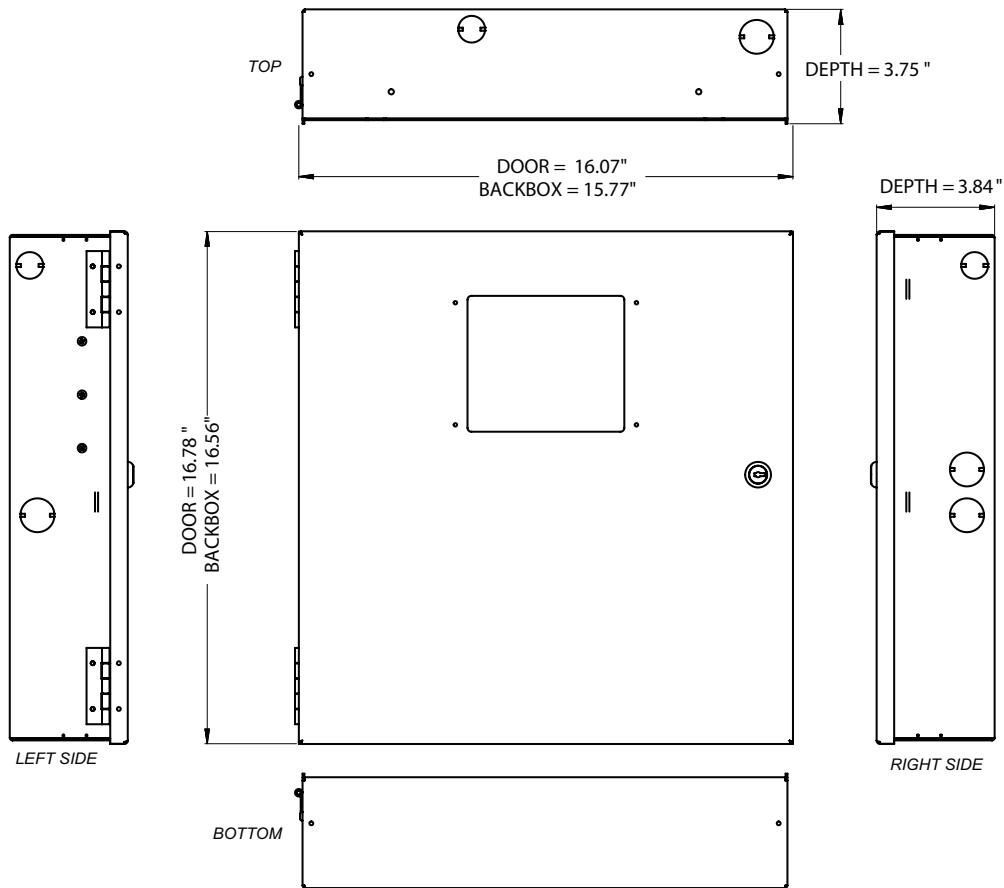

DWG #593-1

Ordering Information

| Model | Description | Stock No. |
|--------|------------------------------------|-----------|
| IPA-60 | Fire Alarm Releasing Control Panel | 3992714 |

Compatible Releasing Devices

Note: For releasing applications please order the Potter EOLD (3005012) for circuits connected to a releasing solenoid or actuator.

| Brand | Description |
|-----------|--|
| Skinner | 73218BN4UNLVN0C112CZ 73212BN4TNLVN0C322C2 |
| Victaulic | 753-E Series |
| Mini Max | MX123 & MX200 w/ 8876677 & 889323 |
| Viking | 11591, 11601, 11602, 13843, & 13844 |
| TLX | PA0036 |

Features

- Terminals Marked with Polarity to assist with installation
- Duplicate terminals for in and out SLC wiring
- Terminals accept 22 to 12 AWG wire sizes
- Installs on single gang, double gang, octagon or 4” square box
- Locking tab prevents unauthorized detector removal
- Product includes 5 year warranty



Application

The Potter PAD100-6DB and PAD100-4DB detector bases are used to install Potter’s addressable smoke and heat detectors. The PAD100-6DB will mount on a single gang, double gang, octagon or 4” square electrical box.

Description

The PAD100-6DB and PAD100-4DB are low-profile, surface mount bases used with Potter’s addressable detectors. The base uses screw-clamp terminals that accept wire ranging from 22 to 14 AWG. When installed on recessed electrical boxes the PAD100-6DB is wide enough to completely cover the back box and the immediate surrounding area. The base is equipped with a locking tab to deter unauthorized removal of the attached detector.

Technical Specifications

| | |
|------------------|--|
| Mounting Options | Single gang, double gang, octagon, and 4” square box |
| Terminals | Screw-Clamp Type |
| Wire Gauge | 22 to 12 AWG |
| Dimensions | Diameter: 6.3 in (166 mm) Height 0.72 in (18 mm) |
| Shipping Weight | 87g (3.07 oz) |
| Material | Durable Plastic |



Reviewed for Code Compliance
Permitting and Inspections Department
Approved with Conditions

02/12/2020

Locking Feature

The PAD100-6DB and PAD100-4DB include a locking feature that prevents removal of the detector without using a tool.

1. To eliminate this feature, break off the locking tab (refer to Figure 1), and then install the detector.

Fig. 1

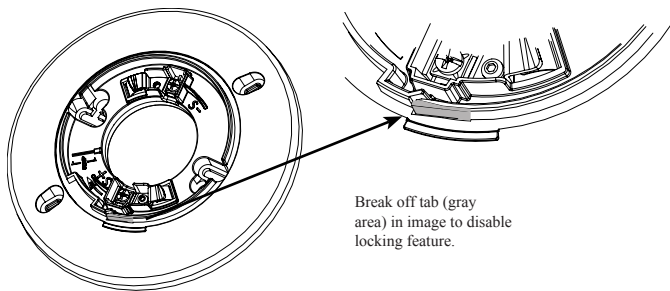

2. To remove the detector from the base when the locking feature has been enabled, insert a small screw driver into the slot on the base to push the plastic tab while simultaneously turning the detector head counter-clockwise.

Fig. 2

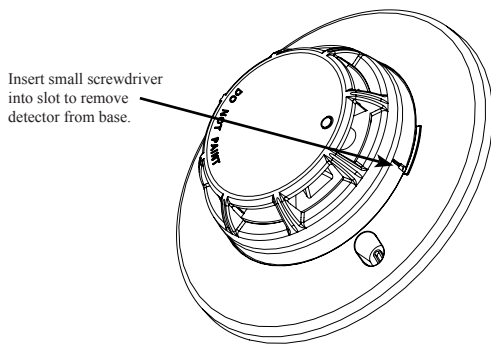

Wiring Diagram

Fig. 3

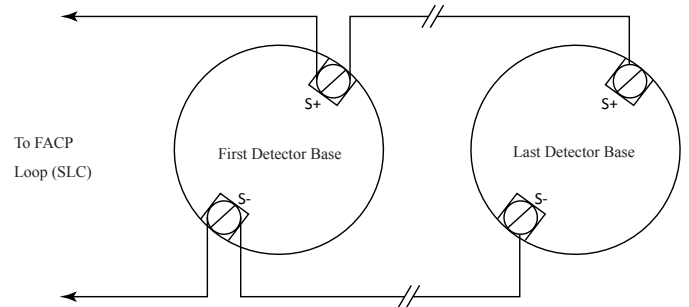

Ordering Information

| Model | Description | Stock No. |
|------------|----------------|-----------|
| PAD100-6DB | 6" Sensor Base | 3992732 |
| PAD100-4DB | 4" Sensor Base | 3992731 |



Reviewed for Code Compliance
Permitting and Inspections Department
Approved with Conditions

02/12/2020

Features

- Selectable Rate of Rise and/or Fixed Heat Detector
- Reliable detection technology
- Wide selectable smoke sensitivity range of 1.0 to 3.5%/foot
- Sensor communicates sensitivity to control panel
- UL listed smoke calibration and sensitivity
- Ambient temperature listing of 32 ° F to 150 ° F
- Optional locking tab to prevent unwanted removal
- Simple DIP switch address setting, no programming tool required
- LED alarm indicator
- Product includes a 5 year warranty



Description

The PAD100-PHD is a listed Analog Addressable smoke sensor and a rate of rise and/or fixed temperature heat sensor compatible with fire alarm control panels that utilize the Potter Addressable Device (PAD) protocol. The PAD100-PHD is a low profile smoke/heat sensor with a wide sensitivity range. The heat sensing portion utilizes a proven thermistor for accurate and reliable heat detection. The sensor and base (not included) are made of a durable plastic in an off-white color to blend in with the ceiling.

The PAD100-PHD is UL listed and has a sensitivity range of 1.0 to 3.5% per foot with a fix temperature alarm threshold of 135°F and can be used for rate of rise applications. See detector spacing limitations below. The PAD100-PHD features drift compensation and has built in dirty detector warning. The PAD100-PHD and the control panel communicate over a proven and robust digital communication path and the system analyzes the information at the particular device. The total polling speed is less than five (5) seconds, well under the UL requirements.

The sensor is compatible with any of the PAD series sensor bases and simply twists on. The PAD100-PHD is addressed using DIP switches in the rear of the sensor and can be easily programmed in the field without special tools.

Setting the Address

Each addressable device on the SLC loop must have a unique address from 1 to 127 to function properly. The address is set using DIP switches.

Before connecting a device to the SLC loop, take the following precautions to prevent potential damage to SLC or device. Verify the following:

1. Power to the device is removed
2. Field wiring is correctly installed.
3. Field wiring has no open or short circuits.

Technical Specifications

| | |
|---|--|
| Operating Voltage | 24 VDC |
| Detector Current Draw | 300 μ A |
| Alarm indicator | 1 LED |
| Alarm set-point range for Smoke | 1.1% - 3.5% |
| Alarm set-point for Heat | 135°F |
| Installation temperature range | 32°F to 120°F (0°C to 49°C) |
| Operating relative humidity range | 0% to 93% (Non-condensing) |
| Start-up time | Max. 1 sec. |
| Maximum number of addresses per loop | 127 |
| Maximum number of lighted indicators in alarm per loop. | 30 |
| Color | Eggshell White |
| Weight (without base) | 3.6 oz |
| Dimensions (without base) | Height: 1.94 in (49mm) Diameter 3.93 in (100mm) |



Reviewed for Code Compliance
Permitting and Inspections Department
Approved with Conditions

02/12/2020

Air Velocity Ratings

The PAD100-PHD has an Open Area of Protection air velocity rating of 0 to 300 feet per minute.

The system has a maximum of 30 LEDs that can be turned on simultaneously. If the system already has 30 LEDs on, the PAD100-PHD will operate even though the LED may not illuminate.

Operation

The PAD100-PHD is an analog addressable sensor that uses one address on the Signaling Line Circuit (SLC) of a compatible fire alarm control panel. The unit communicates with the control panel as it is polled. The LEDs flash every time the unit is polled and they will flash rapidly if the unit is in an active status. The polling LED can be turned off if desired for less conspicuous operation.

The PAD100-PHD with the PAD100-4DB or PAD100-6DB has a low profile to blend into the surrounding environment. The sensor includes an insect screen to prevent foreign objects from reaching the chamber and the can be cleaned to restore operation of a dirty detector.

The system has a maximum of 30 LEDs that can be turned on simultaneously. If the system already has 30 LEDs on, the PAD100-PHD will operate even though the LED will not illuminate.

Sensor Sensitivity

The PAD100-PHD and the compatible control panel work in tandem to keep the sensitivity consistent. As the sensor is installed over time, the sensor compensates for the dirt in the unit until it is out of range. At that time, the panel will indicate a dirty sensor. The sensor will then have to be cleaned or replaced.

The PAD100-PHD can be programmed to provide a maintenance alert prior to reaching the dirty sensor level which will allow for intervention prior to the sensor going into trouble. This allows for sensor replacement or cleaning prior to a nuisance trouble occurs.

NOTE: As required by NFPA, do not install the sensors until all construction is complete and the work area has been thoroughly cleaned. If the sensors have been installed in a construction environment, they should be cleaned or replaced before the system is placed into service.

Spacing

The PAD100-PHD is UL listed with a recommended maximum spacing of 30 feet. Refer to NFPA 72 for specific information regarding detector spacing, placement and special applications.

Compatible Bases

All bases will mount on a single gang, double gang, octagon, 4" square or mud ring electrical box.

| Device | Description | Stock No. |
|-------------|---|-----------|
| PAD100-4DB | 4" Standard Base | 3992731 |
| PAD100-6DB | 6" Standard Base | 3992732 |
| PAD100-IB | 6" base with an isolator module included. | 3992730 |
| PAD100-RB | 6" base with one Form-C relay contact. 2A @ 30VDC, 0.5A @ 125VAC | 3992728 |
| PAD100-SB | 6" base with sounder module included. Sound pattern is provided from external source. | 3992729 |
| PAD100-SPKB | 6" base with speaker included | 3992762 |

Ordering Information

| Model | Description | Stock No. |
|------------|---------------------------------|-----------|
| PAD100-PHD | Photoelectric Smoke/Heat Sensor | 3992734 |



Reviewed for Code Compliance
Permitting and Inspections Department
Approved with Conditions

02/12/2020

Features

- Industry leading 4 line by 40 Character LCD
- Common buttons for navigation
- Common LEDs for status indication
- 31 annunciator per panel
- Maximum wire length of 6,500 feet
- Available in 4 colors
- Product includes a 5 year warranty



Description

The RA-6500 is a LCD remote annunciator for the PFC-6000 series fire control panels. The RA-6500 communicates using a RS-485 connection to the main panel providing common indication of Alarms, Supervisory, Trouble and other system status and control functions.

The RA-6500 features a 4x40 LCD display with LED's for Power, Alarm, Supervisory, Trouble, and Silenced conditions. It can be mounted on a single gang electrical box or a four square electrical box. The annunciator is enclosed in a sheet metal enclosure and has a Potter lock securing the keypad.

Technical Specifications

| | |
|--------------------------|---|
| Standby Current | 20 mA |
| Alarm Current | 25 mA |
| Operating Temperature | 0°C-49°C (32°F-120°F) |
| Operating Humidity Range | 10%-93% @ 30°C (86°F) non condensing humidity |
| Maximum Wire Length | 6500 ft. |
| Maximum Annunciators | 31 |
| Size (WxHxD) | 10" x 7-7/8" x 1-5/8" |
| Wire Gauge | 14 AWG-22 AWG |



Reviewed for Code Compliance
Permitting and Inspections Department
Approved with Conditions

02/12/2020

Installation

The RA-6500 is connected to the PFC-6000 series fire control panels using a four wire RS-485 connection. The connection is power limited and supervised. Up to thirty-one (31) RA-6500 LCD annunciators can be connected using Class B or Class A wiring. Class A wiring requires an optional Class A Expander.

RA-6500 Class B Wiring Example

Fig 1

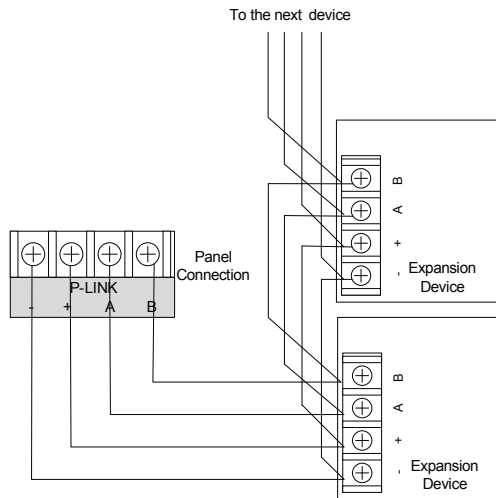

RA-6500 Class A Wiring Example

Fig 2

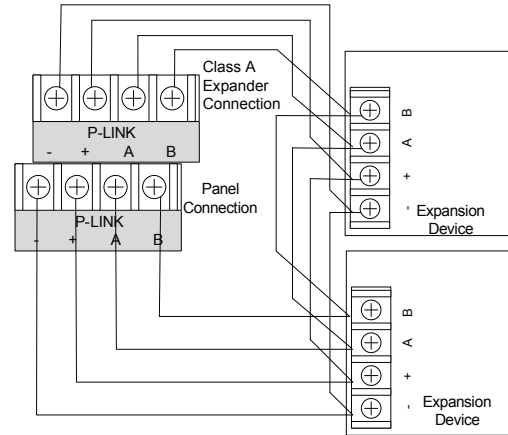

Address Settings

The RA-6500 address is set by dip switch S1 located on the back of the RA-6500. The address must be set in the range of 1 to 31 to be recognized by the control panel.

RA-6500 Remote (Panel View)

Fig 3

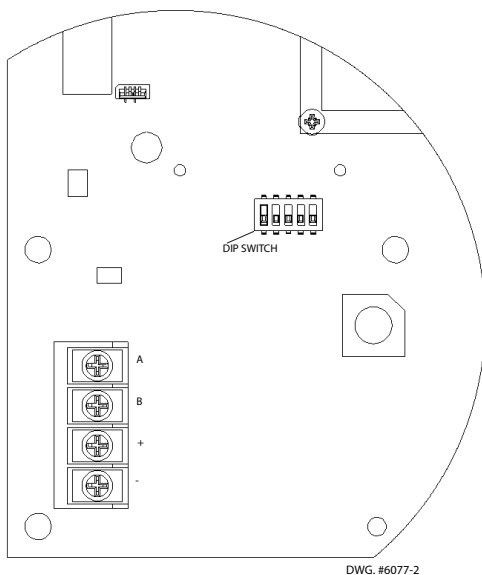

Reviewed for Code Compliance
Permitting and Inspections Department
Approved with Conditions

02/12/2020

Dip Switch Settings

Refer to the table below for dip switch settings per Annunciator Address.

| Annunciator Address | Dip Switch Settings | | | | |
|---------------------|---------------------|------|------|------|------|
| | SW-1 | SW-2 | SW-3 | SW-4 | SW-5 |
| 1 | On | Off | Off | Off | Off |
| 2 | Off | On | Off | Off | Off |
| 3 | On | On | Off | Off | Off |
| 4 | Off | Off | On | Off | Off |
| 5 | On | Off | On | Off | Off |
| 6 | Off | On | On | Off | Off |
| 7 | On | On | On | Off | Off |
| 8 | Off | Off | Off | On | Off |
| 9 | On | Off | Off | On | Off |
| 10 | Off | On | Off | On | Off |
| 11 | On | On | Off | On | Off |
| 12 | Off | Off | On | On | Off |
| 13 | On | Off | On | On | Off |
| 14 | Off | On | On | On | Off |
| 15 | On | On | On | On | Off |
| 16 | Off | Off | Off | Off | On |

| Annunciator Address | Dip Switch Settings | | | | |
|---------------------|---------------------|------|------|------|------|
| | SW-1 | SW-2 | SW-3 | SW-4 | SW-5 |
| 17 | On | Off | Off | Off | On |
| 18 | Off | On | Off | Off | On |
| 19 | On | On | Off | Off | On |
| 20 | Off | Off | On | Off | On |
| 21 | On | Off | On | Off | On |
| 22 | Off | On | On | Off | On |
| 23 | On | On | On | Off | On |
| 24 | Off | Off | Off | On | On |
| 25 | On | Off | Off | On | On |
| 26 | Off | On | Off | On | On |
| 27 | On | On | Off | On | On |
| 28 | Off | Off | On | On | On |
| 29 | On | Off | On | On | On |
| 30 | Off | On | On | On | On |
| 31 | On | On | On | On | On |

Ordering Information

| Model | Description | Stock No. |
|---------|------------------------------|-----------|
| RA-6500 | LCD Annunciator - RED | 3992660 |
| RA-6500 | LCD Annunciator - BLACK | 3992744 |
| RA-6500 | LCD Annunciator - GRAY | 3992745 |
| RA-6500 | LCD Annunciator - LIGHT GRAY | 3992746 |



Reviewed for Code Compliance
Permitting and Inspections Department
Approved with Conditions

02/12/2020

Features

- Allows for communication to Monitoring Station
- Communicates using SIA-DCS or Ademco Contact ID Protocols
- For use with IPA, AFC, and ARC series Addressable Panels and PFC-4064 Conventional Panel
- Status LEDs indicate operation of DACT card
- Installs with ease behind main panel LCD display via User Interface bracket
- Device address is set internally to address 1
- Includes two (2) RJ45 phone cords

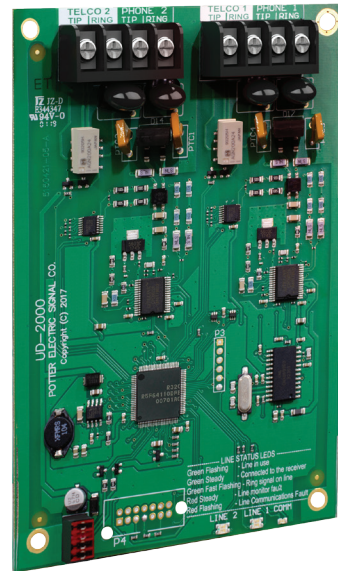

Description

The UD-2000 Digital Alarm Communicator Transmitter (DACT) provides for up to two (2) phone lines for communication to a monitoring station. The UD-2000 communicates using the SIA-DCS or Ademco Contact ID protocols. When enabled, the DACT automatically monitors each phone line or voltage and has the ability to seize the line and connect with a remote receiver. Once the communication is complete, the DACT will hang up.

The DACT is provided with terminal blocks for each phone line and two RJ45 cords. In order for the DACT to work properly, it must be installed on a plain old telephone service (POTS) line or equivalent deemed by the authority having jurisdiction. The DACT must be installed before any other equipment to ensure it can seize the phone line.

Phone lines are high voltage and should be run in a separate conduit from other circuits. The wire conductors connecting the DACT to the phone system should be 26 AWG or larger.

Technical Specifications

| | |
|--------------------------|--|
| Operating Voltage | 22.0-24.0V |
| Standby Current | 16mA |
| Alarm Current | 23mA |
| Max UD-2000s per panel | 1 |
| Dimensions | 4"W * 6"H * 1-5/8"D |
| Operating Temperatures | 0°C - 49°C (32°F- 120°F) |
| Operating Humidity Range | 10% - 93% @ 30°C (86°F) (non-condensing) |
| Mounting Options | In FACP Behind keypad |
| Shipping Weight | 0.47 lbs |



Reviewed for Code Compliance
Permitting and Inspections Department
Approved with Conditions

02/12/2020

RJ31X Phone Jack to UD-2000
Plain Old Telephone (POTS) lines

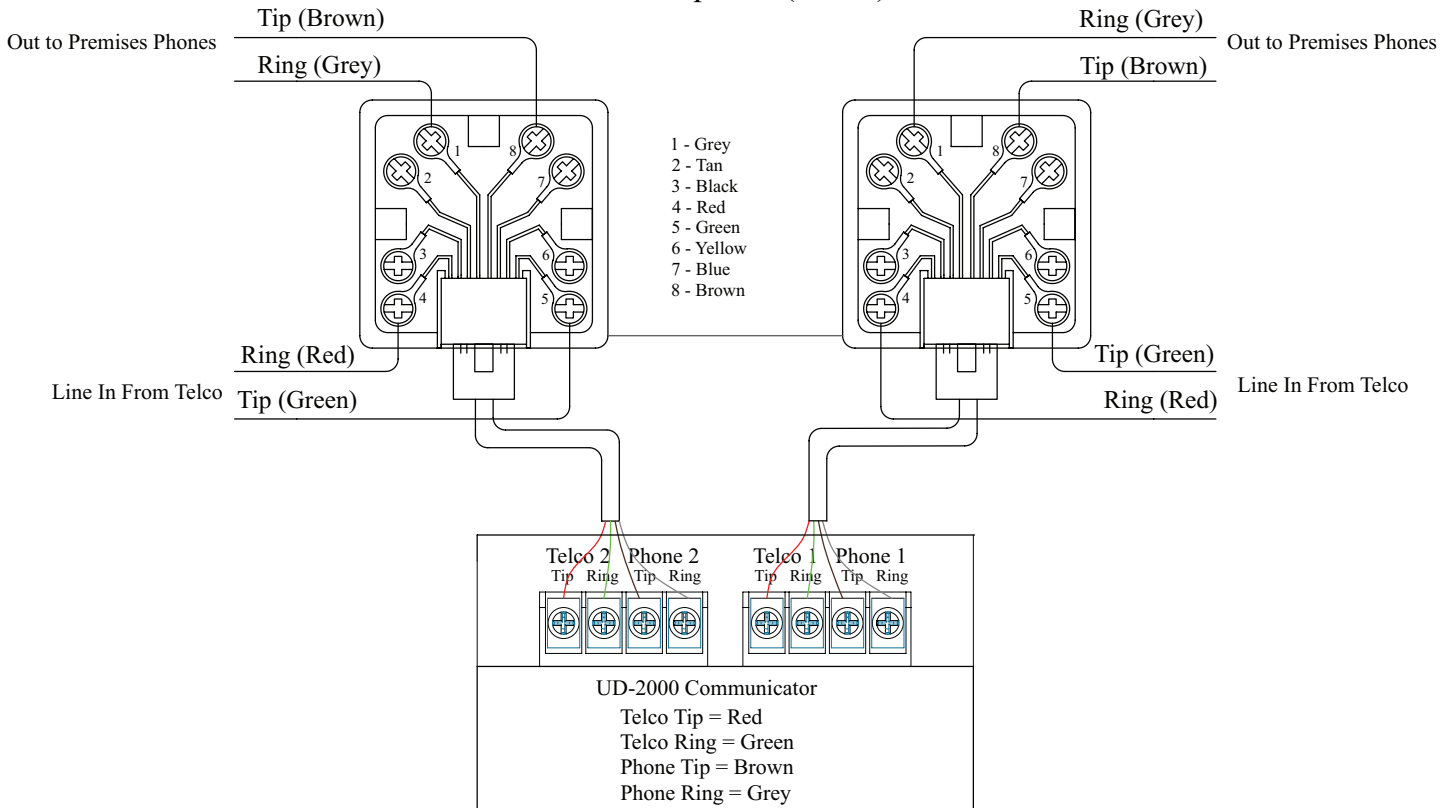

NOTICE

Install in accordance with compatible fire alarm control panel installation manual

Installation

The UD-2000 DACT is connected to the control panel using the provided four-wire cable connection (P/N 5210514) between P4 and UD-2000 P1. The connection is power limited and supervised.

1. Power system down.
2. Slide the UD-2000 into the card guides located under the User Interface bracket.
3. Secure the UD-2000 to the User Interface bracket using the provided #6-32x3/8" screw
4. Install the provided four-wire conductor jumper between UD-2000 P1 and P4.



Reviewed for Code Compliance
Permitting and Inspections Department
Approved with Conditions

02/12/2020

UD-2000 DACT Installation on Small Platform Panel

Fig 1

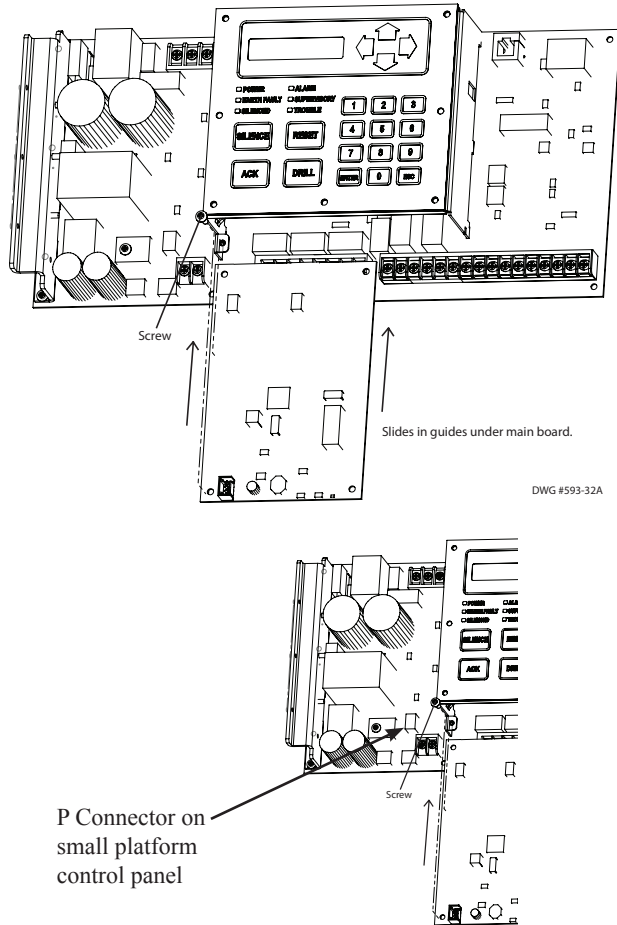

UD-2000 DACT Installation on Large Platform Panel

Fig 2

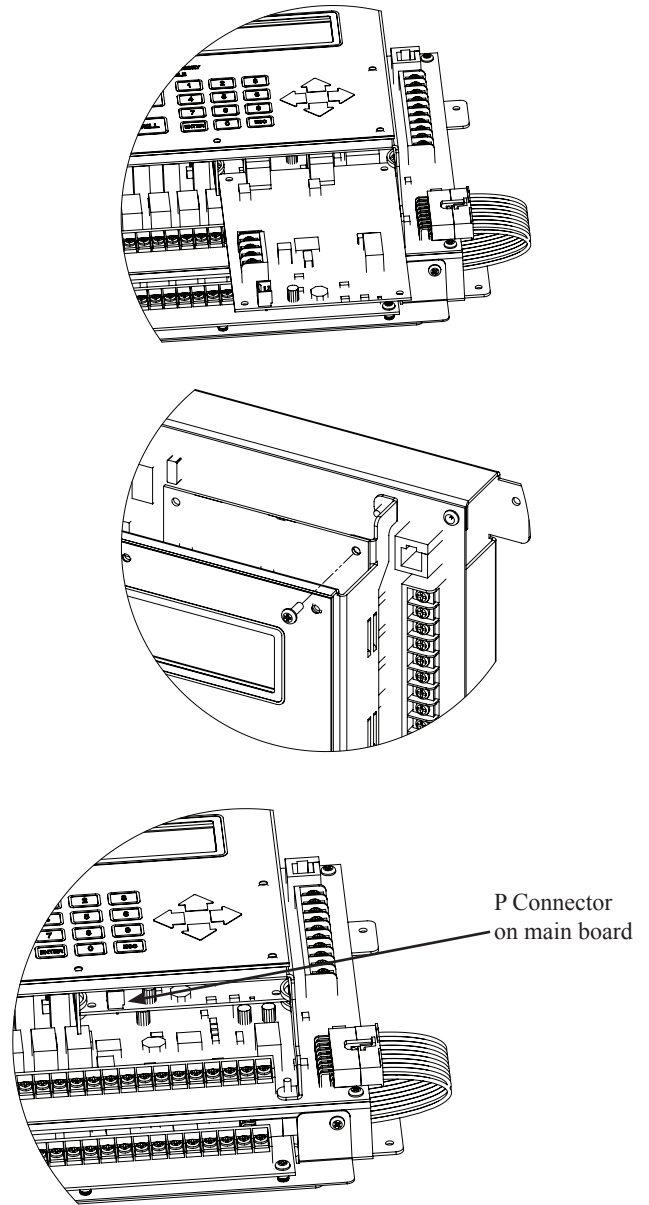

Ordering Information

| Model | Description | Stock No. |
|---------|----------------------------|-----------|
| UD-2000 | Digital Alarm Communicator | 3992769 |



Reviewed for Code Compliance
Permitting and Inspections Department
Approved with Conditions

02/12/2020

IPA-60
Battery & Voltage Drop
Calculations

Project Name: Standby Hours:
 Alarm Mins:
 Installed By: Batt Efficiency:
 Designed By: SLC Type:
 Date: NAC Source Voltage:

Model #: IPA-60

Max Panel Current (amps): 5

Panel ID:

User assumes all responsibility to ensure the quantities and current draw values in this worksheet are accurate prior to submittal.

Location:

| Qty | FACP Part # | Description | Standby (amps) | | Alarm (amps) | |
|-----|-------------|-------------------------|-----------------------|--------------|---------------------|--------------|
| | | | Each | Total | Each | Total |
| 1 | IPA-60 | Analog Addressable FACP | 0.130 | 0.130 | 0.220 | 0.220 |
| | | | Panel Standby: | 0.130 | Panel Alarm: | 0.220 |

| P-LINK (RS-485) | | | Standby | | Alarm | |
|-----------------|-----------------|------------------------------|---------|-------|-------|-------|
| | MC-1000 | Multi-Connect Expander | 0.010 | | 0.010 | |
| 1 | UD-1000 | DACT Card | 0.016 | 0.016 | 0.023 | 0.023 |
| 1 | RA-6075R | LCD Annunciator | 0.020 | 0.020 | 0.025 | 0.025 |
| | RA-6500R(F) | Flush Mount LCD Annunciator | 0.020 | | 0.050 | |
| | LED-16(F) | Flush Mount LED Annunciator | 0.025 | | 0.025 | |
| | LED-16 | LED Annunciator LED Power* | 0.015 | | 0.210 | |
| | CA-6075 | Class A Module | 0.012 | | 0.044 | |
| | PSN-1000(E) | Power Expander | 0.015 | | 0.015 | |
| | PAD100-SLCE-127 | SLC Expander | 0.060 | | 0.060 | |
| | NOHMI-SLCE-127* | SLC Expander | 0.060 | | 0.060 | |
| | RLY-5 | Relay Expander | 0.025 | | 0.035 | |
| | RLY-5 | Relay Expander Power* | 0.010 | | 0.135 | |
| | DRV-50 | LED Driver Module | 0.025 | | 0.025 | |
| | DRV-50 | LED Driver Module LED Power* | 0.010 | | 0.215 | |
| | FCB-1000 | Fire Communications Bridge | 0.025 | | 0.025 | |
| | FIB-1000 | Fiber Interface Board | 0.030 | | 0.030 | |
| | SPG-1000 | Serial Parallel Gateway | 0.040 | | 0.040 | |

* REQUIRED IF USING NOHMI PROTOCOL SLC DEVICES

(Maximum current draw on P-Link limited to 1 Amp)

P-LINK Standby: **0.036** P-LINK Alarm: **0.048**

*Only enter quantity if PLINK power is being used to power devices

| SLC Devices | | | Standby | | Alarm | |
|----------------------------|--------------------------|---|----------------------|----------------------|----------------------|----------------------|
| 1 | PAD100-PD | Analog Photo Smoke | 0.000300 | 0.000300 | 0.000300 | 0.000300 |
| | PAD100-PHD | Analog Photo Smoke/Heat | 0.000300 | | 0.000300 | |
| | PAD100-HD | Analog Fixed Temp Heat | 0.000300 | | 0.000300 | |
| | PAD100-CD | Analog Carbon Monoxide Detector | 0.000300 | | 0.000300 | |
| | PAD100-DUCT | Addressable Duct Detector | 0.000300 | | 0.000300 | |
| | PAD100-DRTS | Duct Remote Test Switch | 0.010000 | | 0.015000 | |
| | PAD100-DUCTR* | Addressable Duct Detector w/Relay | 0.000500 | | 0.000500 | |
| 1 | PAD100-PSSA/PSDA | Addressable Pull Station Single/Dual Action | 0.000200 | 0.000200 | 0.000200 | 0.000200 |
| | PAD100-MIM | Micro Input Module | 0.000200 | | 0.000200 | |
| | PAD100-SIM | Single Input Module | 0.000240 | | 0.000240 | |
| 2 | PAD100-DIM | Dual Input Module | 0.000240 | 0.000480 | 0.000240 | 0.000480 |
| | PAD100-RM | Relay Module | 0.000240 | | 0.000240 | |
| | PAD100-OROI | One Relay One Input Module | 0.000240 | | 0.000240 | |
| | PAD100-TRTI | Two Relay Two Input Module | 0.000240 | | 0.000240 | |
| | PAD100-ZM* | Conventional Zone Module | 0.000240 | | 0.000240 | |
| | PAD100-NAC* | Notification Appliance Circuit | 0.000200 | | 0.000200 | |
| | PAD100-SM | Speaker Module | 0.000240 | | 0.000240 | |
| | PAD100-IM | Isolator Module | 0.000150 | | 0.000150 | |
| | PAD100-LED | LED Module | 0.000240 | | 0.000240 | |
| | PAD100-LEDK | Addressable LED w/ Key Switch | 0.000200 | | 0.000200 | |
| | PAD100-SB* | Addressable Sounder Base | 0.000200 | | 0.000200 | |
| | PAD100-RB | Addressable Relay Base | 0.000200 | | 0.000200 | |
| | PAD100-IB | Addressable Isolator Base | 0.000150 | | 0.000150 | |
| | PSA | Analog Photo Smoke | 0.000325 | | 0.000325 | |
| | PSHA | Analog Photo Smoke/Heat | 0.000325 | | 0.000325 | |
| | RHA | Analog Rate of Rise Heat | 0.000325 | | 0.000325 | |
| | FHA | Analog Fixed Temp Heat | 0.000325 | | 0.000325 | |
| | DDA | Addressable Duct Detector | 0.000325 | | 0.000325 | |
| | APS-SA/APS-DA | Addressable Pull Station Single/Dual Action | 0.000325 | | 0.000325 | |
| | MCM | Mini Contact Input Module | 0.000325 | | 0.000325 | |
| | SCM-4 | Single Contact Input Module | 0.000325 | | 0.001000 | |
| | DCM-4 | Dual Contact Input Module | 0.000325 | | 0.001000 | |
| | TRM-4 | Twin Relay Output Module | 0.000325 | | 0.001000 | |
| | CIZM-4 * | Conventional Zone Input Mod | 0.000325 | | 0.001000 | |
| | MOM-4 * | Monitored Output Module | 0.000325 | | 0.001000 | |
| | ARB * | Detector Base w/Relay | 0.000325 | | 0.000325 | |
| | ASB * | Detector Base w/Sounder | 0.000325 | | 0.000325 | |
| | SCI ** | Short Circuit Isolator (Class A) | 0.000325 | | 0.002340 | |
| | AIB ** | Detector Base w/Isolator (Class A) | 0.000325 | | 0.002340 | |
| | IM/IB/SCI/AIB Class B ** | Current Draw from Install Manual | <input type="text"/> | <input type="text"/> | <input type="text"/> | <input type="text"/> |
| SLC Loop Alarm LED Current | | | 0.000000 | 0.000000 | 0.036000 | 0.036000 |
| | | | SLC Standby: | 0.000980 | SLC Alarm: | 0.036980 |

* Requires Aux Power (Configure Below)

** See the installation manual for special considerations when installing AIB, SCI devices on Class B loops.



Reviewed for Code Compliance
Inspection and Inspections Department
Approved with Conditions

02/12/2020

| NAC Circuits (See NAC Configuration below) | | | Standby (amps) | Alarm (amps) |
|--|-----|-------------|-----------------------------|---------------------------|
| Ckt | Use | Description | Total | Total |
| 1 | | | 0.00000 | 3.00000 |
| 2 | | | 0.00000 | 1.00000 |
| | | | NAC Standby: 0.00000 | NAC Alarm: 4.00000 |

| I/O Circuits (See I/O Configuration below) | | | Standby (amps) | Alarm (amps) |
|--|-----|-------------|-----------------------------|---------------------------|
| Ckt | Use | Description | Total | Total |
| 1 | | | 0.00000 | 0.00000 |
| 2 | | | 0.00000 | 0.00000 |
| | | | I/O Standby: 0.00000 | I/O Alarm: 0.00000 |

| Battery Calculation Summary | | | Standby (amps) | Alarm (amps) |
|--|--|--|-----------------|-----------------------------|
| Panel Current: | | | 0.13000 | 0.22000 |
| P-Link Current: | | | 0.03600 | 0.04800 |
| SLC Device Current: | | | 0.00098 | 0.03698 |
| NAC Circuit Current: | | | 0.00000 | 4.00000 |
| I/O Circuit Current: | | | 0.00000 | 0.00000 |
| Total Standby: | | | 0.166980 | Total Alarm: 4.30498 |
| Standby Hours: | | | 24 | Alarm Mins: 5 |
| AH Required: | | | 4.01 | AH Required: 0.36 |
| Total Combined Standby & Alarm AmpHours Required: | | | 4.37 | |
| Efficiency Factor: | | | 80% | |
| Required Battery AmpHours: | | | 5.46 | |
| Battery AmpHours Provided: | | | 7 | |

Note: The cabinet will house two 8 AH or 18 AH batteries. The charging circuit is rated for up to two 55 AH batteries.

SLC Loop Type: Class B
 Device Addresses Used: 4
 Device Addresses Available: 60

5



Reviewed for Code Compliance
 Permitting and Inspections Department
 Approved with Conditions

02/12/2020

DURACELL® SLA Batteries ULTRA

General Purpose
Backup and deep cycle applications

Duracell® Ultra SLA technology offers high-density power that outperforms traditional lead acid batteries. The Absorbed Glass Mat (AGM) construction is designed for efficient gas recombination and allows for maintenance-free operation. Duracell® Ultra SLA batteries maintain their high capacity with a design that is resistant to damage caused by deep discharge. Every Duracell® Ultra SLA battery is inspected to ensure the highest standards in materials and fabrication.



50-150
Cycles at 100% Discharge



**SPILL
PROOF**
GUARANTEE



Reviewed for Code Compliance
Permitting and Inspections Department
Approved with Conditions
02/12/2020

Features:

- Duracell® Ultra SLA GEL batteries contain a proprietary grid alloy formula combined with advanced plate curing techniques to provide maximum performance.
- Duracell® Ultra batteries contain a unique electrolyte formula with a special sub-colloid additive for higher reliability and longer life.
- Will achieve more life cycles than standard AGM and Deep Cycle batteries.
- The unique construction and sealing techniques of these batteries are guaranteed to give you leak-proof operation.
- Heavy-duty lead calcium tin alloy grids provide an extra margin of performance and service life in cyclic applications, even after repeated over-discharges.
- Quality Assurance Engineers monitor and control the entire production process.
- Recycling of used SLA batteries available.
- Delivery available.



CASE
Quantities
AVAILABLE

Sealed
**Lead
Acid**



Maintenance Free



Spill Proof
Design



1 Year
Warranty



Stringent Quality
Control

DURACELL® SLA Batteries ULTRA



PROJECT NAME: _____

CATALOG # _____

FIXTURE TYPE _____

NOTES _____

General Purpose

Reviewed for Code Compliance
Permitting and Inspections Department
Approved with Conditions
02/12/2020

| Battery | Volts | Capacity Ah (20Hrs) | Dimensions (LxWxH Inches) | | | Terminal Type | Group Size | Weight (Lbs.) |
|----------------|-------|---------------------|---------------------------|------|------|----------------------------------|------------|---------------|
| DURA12-0.8WL | 12V | 0.8 | 3.78 | 0.98 | 2.4 | WL | - | 0.77 |
| DURA12-1.3F | 12V | 1.3 | 3.82 | 1.69 | 2.28 | F1, T1 | - | 1.37 |
| DURA12-2.3F | 12V | 2.3 | 6.97 | 1.38 | 2.64 | F1, T1 | - | 2.04 |
| DURA12-2.9F | 12V | 2.9 | 3.11 | 2.2 | 3.9 | F1, T1 | - | 2.36 |
| DURA12-3.3F | 12V | 3.3 | 5.28 | 2.64 | 2.63 | F1, T1 | - | 3.18 |
| DURA12-3.3F2 | 12V | 3.3 | - | - | - | - | - | - |
| RAYA12-4F | 12V | 4 | 3.54 | 2.76 | 4.21 | F1, T1 | - | - |
| DURA12-5F | 12V | 5 | 3.54 | 2.76 | 4.21 | F1, T1 | - | - |
| DURA12-5F2 | 12V | 5 | 3.56 | 2.77 | 3.94 | F2, T2 | - | - |
| DURA12-5.1A | 12V | 5.1 | 5.51 | 1.89 | 4.21 | F1, T1 | - | 4.6 |
| DURA12-5.5F | 12V | 5.5 | 3.54 | 2.76 | 3.98 | - | - | - |
| RAYA12-7F | 12V | 7 | 5.95 | 2.56 | 3.94 | F1, T1 | - | - |
| DURA12-7F | 12V | 7 | 5.94 | 2.56 | 3.94 | F1, T1 | - | - |
| DURA12-7F2 | 12V | 7 | 5.94 | 2.56 | 3.7 | F2, T2 | - | - |
| DURA12-8F | 12V | 8 | 5.94 | 2.56 | 3.94 | F1, T1 | - | - |
| DURA12-8F2 | 12V | 8 | 5.94 | 2.56 | 3.94 | F2, T2 | - | - |
| DURA12-9NB | 12V | 9 | 5.95 | 2.56 | 3.9 | NB, J | - | - |
| DURA12-9F2 | 12V | 9 | 5.95 | 2.56 | 3.94 | F2, T2 | - | - |
| DURA12-10F2 | 12V | 10 | 5.95 | 2.54 | 4.38 | F2, T2 | - | 7.5 |
| DURA12-11NB | 12V | 11 | 5.28 | 3.15 | 6.5 | - | - | 10.1 |
| DURA12-12F2 | 12V | 12 | 5.94 | 3.9 | 3.98 | F2, T2 | - | - |
| DURA12-12F | 12V | 12 | 5.94 | 3.86 | 3.86 | F1, T1 | - | - |
| DURA12-14F2 | 12V | 14 | 5.94 | 3.86 | 3.98 | F2, T2 | - | 8.91 |
| DURA12-18F2 | 12V | 18 | 7.13 | 3.03 | 6.57 | F2, T2 | - | - |
| DURA12-18NB | 12V | 18 | 7.13 | 3.03 | 6.57 | NB, J | - | 12.43 |
| DURA12-26NB | 12V | 26 | 6.5 | 6.93 | 4.92 | NB, J | - | 20.7 |
| DURA12-35C | 12V | 35 | 7.72 | 5.16 | 6.5 | C | - | 27.3 |
| DURA12-44C/FR | 12V | 46 | 7.8 | 6.54 | 6.85 | C | - | 38 |
| DURA12-55C/FR | 12V | 55 | 9.02 | 5.43 | 8.35 | - | - | 42.1 |
| DURA12-80C/FR | 12V | 80 | 10.24 | 6.65 | 8.46 | C | - | - |
| DURA12-100C/FR | 12V | 100 | 12.09 | 6.65 | 8.46 | C | - | 74.6 |
| DURA12-140C/FR | 12V | 140 | 13.43 | 6.81 | 11.3 | C | - | 108 |
| DURA4-4.5F2 | 4V | 4.5 | 1.85 | 1.85 | 3.98 | F2, T2 | - | 1.4 |
| DURA6-1.3F | 6V | 1.3 | 3.82 | 0.94 | 2.28 | F1, T1 | - | 0.715 |
| DURA6-2ST | 6V | 2 | 1.69 | 1.45 | 2.99 | ST | - | 0.75 |
| DURA6-2.9F | 6V | 2.9 | 2.6 | 1.46 | 3.82 | F1, T1 | - | 1.26 |
| DURA6-3.3F | 6V | 3.3 | 5.28 | 1.34 | 2.64 | F1, T1 | - | 1.65 |
| RAYA6-4F | 6V | 4 | 2.76 | 1.85 | 4.13 | F1, T1 | - | - |
| DURA6-5SP | 6V | 5 | 2.6 | 2.6 | 4.53 | SP | - | 2.09 |
| DURA6-5F | 6V | 5 | 2.76 | 1.85 | 4.21 | F1, T1 | - | - |
| DURA6-7.2F | 6V | 7.2 | 5.94 | 1.34 | 3.68 | F1, T1 | - | 2.43 |
| DURA6-8.2F | 6V | 8.2 | 3.9 | 2.24 | 4.53 | F1, T1, | - | 3.8 |
| DURA6-10F | 6V | 10 | 5.94 | 1.97 | 3.98 | F1, T1 | - | 4.851 |
| DURA6-12F | 6V | 12 | 5.94 | 1.97 | 3.98 | F1, T1 | - | - |
| DURA6-12F2 | 6V | 12 | 5.94 | 1.97 | 3.98 | F2, T2 | - | 4.602 |
| RAYA6-14T2 | 6V | 14 | 4.25 | 2.8 | 5.51 | H | - | 6.24 |
| DURA6-14A | 6V | 14 | 4.25 | 2.8 | 5.51 | F1 (-) F2 (+), T1 (-) T2 (+), FP | - | 6.16 |
| DURA6-42F2 | 6V | 42 | 6.25 | 3.37 | 6.37 | F2, T2 | - | 16.64 |
| DURA6-42NB | 6V | 42 | 6.34 | 3.43 | 6.42 | NB, J | - | 16.62 |
| DURA6-200C | 6V | 200 | 12.05 | 6.65 | 8.63 | C | - | - |
| DURA8-3.2F | 8V | 3.2 | 5.28 | 1.44 | 2.48 | F1, T1 | - | 1.65 |

Visit batteriesplus.com for warranty information

NO EXCUSES!



E120V-GT

Hybrid Surge Protection Device

Safety and performance is what Eclips is all about. While there are many varying criteria to be considered for surge protective devices (SPD), if the design engineer neglects the importance there can be serious implications for the client and equipment.

Every piece of electrical equipment is designed to operate at a specified nominal voltage. Typically equipment is designed to handle minor variations. However external sources such as lightning, motors, and short circuits cause wild and damaging variations.

Critical systems wired to your electrical service like Fire Alarm Control Panels (FACP), Mass Notification systems, amplifiers, motors, pumps (HVAC), power boosters and many more must require appropriate levels surge protection. The E120 series is an ideal choice for your 120V AC applications. because it has the robustness not only to absorb a spike, but to clamp long enough to trip the branch circuit breaker and still be functional for additional surges.

The number one cause of destruction, degradation and downtime of critical electrical equipment is from power surges and lightning strikes.

The E120V-GT device is an ideal solution to protect equipment. UL listed it maintains system integrity and protects against transients introduced into / onto electrical lines via poor atmospheric and utility conditions as well as internally generated inductive loads and transient TVSS. It reduces system downtime associated with power surges and lightning strikes. Prevents destruction and degradation of electrical components in the system. Fix your nuisance and non-billable service calls as a result of transients and poor power quality and show your customer you care about system integrity.

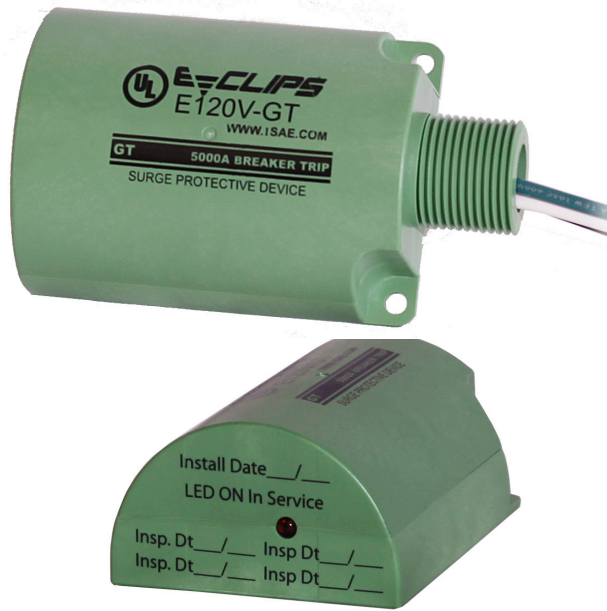

Standard Features:

- Available in 120 VAC
- UL Listed 1449 3rd Edition Type 2 & 3 2X to open circuit breaker @5000A
- Includes lockout & labels per NFPA 72 2013 10.6.5.2
- Surface or conduit mounting
- Diagnostic indicator light
- Self restoring
- 3 Wire device (18" length)

Reviewed for Code Compliance
Permitting and Inspections Department
Approved with Conditions
02/12/2020



**ISO 9001
REGISTERED
COMPANY**



RU - Uses UL Recognized Components



Space Age Electronics, Inc.
www.1SAE.com
800.486.1723 Toll Free
508.485.0966 Local
508.485.4740 Fax

Specifications:

All 120volt AC equipment will have Transient Voltage Surge Suppression (TVSS) protection manufactured by Space Age Electronics, Inc., part number E120V-GT ECLIPS Brand. The Unit shall be UL listed to standard 1449 rev 3. The unit will be labeled clearly with indelible ink. Mounting can be conduit mounted with a 3/4" pipe threaded nipple to secure in panel, or surface panel mount with 2 external mounting holes. The unit shall have thermal fuses to protect against fire in short circuit conditions. The E120V will have 18" long, 14 gauge wires (3x) ground wire must be green. The enclosure will be a non dielectric material UL94 QMFZ2/8 grade material providing UV protection. The unit shall provide visual indication (LED) that unit is protecting and functioning.

Specifications - Performance:

| | |
|--|--|
| Short Circuit Current Rating (SCCR) : | 5KA |
| Maximum Surge Current (8x20µs) : | 25,000 Amps |
| Enclosure Material : | UL94 QMFZ2/8 (green) |
| Energy Dissipation Joules : | 500 Joules |
| VPR=700(L – N) 700 (L – G) 600 (N – G) | |
| Capacitance : | < 2,000 pf |
| Clamping Response Time : | < 5 nanoseconds |
| Current : | Non-Load Bearing |
| Max Operating Voltage (MCOV) : | 140 volts AC, 50/60 Hz |
| Clamping Voltage : | 230 Volts RMS |
| Design : | Thermally Fused Hybrid |
| Operation Indicators : | LED |
| Survivability : | UL rated X2 @5000 Amps to open Series external circuit breaker |

Specifications - Operating:

| | |
|------------------------------|------------------|
| Service Voltage : | 120 Single Phase |
| Circuits Protected : | L-N L-G N-G |
| Connection Type : | Hardwired |
| Installation Configuration : | Parallel |

Specifications - Physical:

| | |
|-------------------------|-------------------------|
| Weight : | 5.2oz |
| Dimensions : | 2.75" x 1.55" x 4" long |
| Operation Temperature : | -40 to +85° C |

Specifications - Compliance:

| | |
|---------------|---------------------------|
| UL Listed : | 1449 Third Edition - VZCA |
| File Number : | E319370 Vol. 1 Sec. 1 |

Mechanical Drawing:

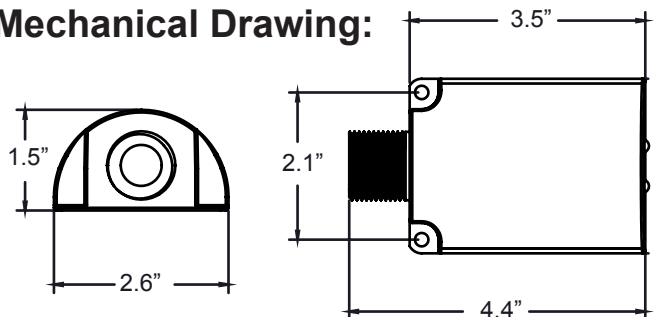

Wiring Diagram:

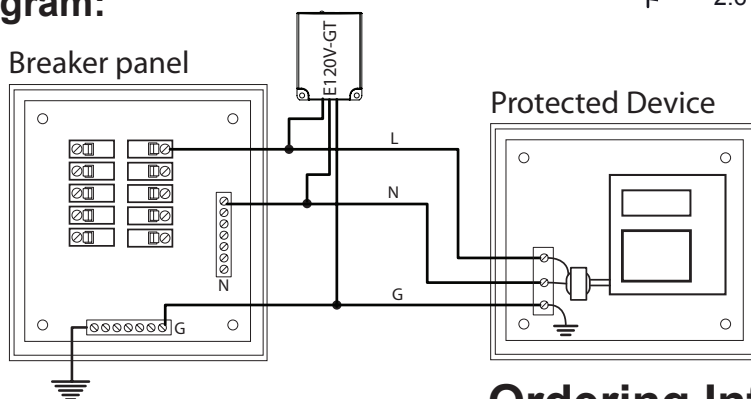

Ordering Information:

| Part # | Description |
|----------|-------------------------------------|
| E120V-GT | 120V Hybrid Surge Protective Device |
| ELOCK-FA | Circuit Lockout Kit |



Reviewed for Code Compliance
Permitting and Inspections Department
Approved with Conditions
02/12/2020



Space Age Electronics, Inc.
www.1SAE.com
800.486.1723 Toll Free
508.485.0966 Local
508.485.4740 Fax

No Excuses, Just Solutions!

This document is subject to change without notice, see doc # ED0479 for legal disclaimer

Sequence of Operations



Reviewed for Code Compliance
 Permitting and Inspections Department
 Approved with Conditions
 02/12/2020

| | Audio/visual activation globally on general alarm | Audio/visual activation locally within the unit on local alarm only | Activate audible/visual signal at FACP & Annunciator | Device Description at FACP & Annunciator | Shutdown of HVAC equipment | Log event in system history | Activate Elevator Fire Hat | Activate Elevator primary or secondary control | Activate Elevator shunt trip | Silence of audible devices Including FACP & annunciator | Release door holders | Release locked doors | Event acknowledgement | Reset of all system functions and all visual devices | Remote transmission to Central Station A=alarm; T=trouble; S=Supervisory; L = log only | Remote indicator |
|---|---|---|--|--|----------------------------|-----------------------------|----------------------------|--|------------------------------|---|----------------------|----------------------|-----------------------|--|---|------------------|
| Manual Pull Stations | X | | X | X | | X | | | | | X | X | | | A | |
| Smoke detectors common area | X | | X | X | | X | | | | | X | X | | | A | |
| Smoke detectors elevator lobbies | X | | X | X | | X | | X | | | X | X | | | A | |
| Smoke Detectors elevator shaft/machine room | X | | X | X | | X | X | X | | | X | X | | | A | |
| Duct mounted Smoke Detectors | | | X | X | X | X | | | | | | | | | S | X |
| Smoke detectors with sounder base | | X | X | X | | X | | | | | | | | | S | |
| Sounder on smoke detector with sounder base | X | | | | | | | | | | | | | | | |
| Heat Detectors common area | X | | X | X | | X | | | | | X | X | | | A | |
| Heat Detectors Elevator shaft/machine room | X | | X | X | | X | X | X | | | X | X | | | A | |
| Sprinkler flow or pressure switches | X | | X | X | | X | | | | | X | X | | | A | |
| Sprinkler Tamper, low temp, or low air | | | X | X | | X | | | | | | | | | S | |
| Secondary fire panel such as kitchen hood | X | | X | X | | X | | | | | X | X | | | A | |
| FACP/annunciator silence button | | | X | X | | X | | | | X | | | | | L | |
| FACP/annunciator acknowledge button | | | X | X | | X | | | | | | | X | | | |

Sequence of Operations



Reviewed for Code Compliance
Permitting and Inspections Department
Approved with Conditions
02/12/2020

| | Audio/visual activation globally on general alarm | Audio/visual activation locally within the unit on local alarm only | Activate audible/visual signal at FACP & Annunciator | Device Description at FACP & Annunciator | Shutdown of HVAC equipment | Log event in system history | Activate Elevator Fire Hat | Activate Elevator primary or secondary control | Activate Elevator shunt trip | Silence of audible devices Including FACP & annunciator | Release door holders | Release locked doors | Event acknowledgement | Reset of all system functions and all visual devices | Remote transmission to Central Station A=alarm; T=trouble; S=Supervisory; L = log only | Remote indicator |
|-------------------------------|---|---|--|--|----------------------------|-----------------------------|----------------------------|--|------------------------------|---|----------------------|----------------------|-----------------------|--|---|------------------|
| FACP/annunciator reset button | | | X | X | | X | | | | | | | | X | L | |
| Removal of any device | | | X | X | | X | | | | | | | | | T | |
| Ground fault | | | X | X | | X | | | | | | | | | T | |
| System wiring "open" | | | X | X | | X | | | | | | | | | T | |
| AC Power loss | | | X | X | | X | | | | | | | | | T | |
| Secondary power loss | | | X | X | | X | | | | | | | | | T | |
| Telephone line loss | | | X | X | | X | | | | | | | | | T | |



Reviewed for Code Compliance
Permitting and Inspections
Department
02/12/2020

**NO
EXCUSES!**



FAD

Fire Alarm Documents Records / Programs / Software



The FAD is the perfect fit to meet the demanding code requirements today. SAE's number one goal is to manufacture code compliant solutions and this product allows you to do just that. NFPA 72 section 6.2.2.1 states, "A record of installed software and firmware version numbers shall be maintained at the location of the fire alarm control unit."

This durable 16 gauge steel enclosure with a solid piano hinge and key lock will keep all of your code required documents in one safe place. With a 2GB USB flash drive it stores your fire alarm software safe and secure eliminating the occurrences of the software not being on site when technicians arrive to service the system. Along with your fire alarm software you can store your test & inspection documents, service records, manuals & AS built drawings for the system. Using a standard USB B connector it allows you to plug in with any standard SB printer cable to upload or download information.

NFPA 72 section 10.18.2.1.2.8 If the documents are located in a separate enclosure or cabinet, the separate enclosure or cabinet shall be prominently labeled
FIRE ALARM DOCUMENTS.

Standard Features:

- Installed with a 2 gig digital flash drive with USB B connector
- 2 Key ring hooks to hold system keys
- Business card holder for key contacts
- Overall Dimensions are 12" x 13" tall and 2 ¼ deep
- 16 gauge steel box and cover for security
- durable powercoat baked on finish other colors available
- standard ¾" cat 30 key lock other lock assemblies available
- Solid stainless steel piano hinge
- permanently screened white ink 1" high "Fire Alarm Documents"
- Legend sheet for passwords and system information

The FAD is designed to hold critical manuals and documents with a durable steel sleeve. It has designated hooks to organize key rings and hold important business cards for easy access and reference. Inside the cover it has a organized note table that allows for documentation for passwords and other critical system information. The steel sleeve can be easily removed to hold a 1.5" three ring binder.

The innovation of a single gang cutout inside the box to implement the infinity line products with conduit knockout access enables you to provide other system functions for test and inspection. A drill switch or a shut off switch for testing are just a few examples. See the complete line of Infinity products for single gang electrical product solutions.



**ISO 9001
REGISTERED
COMPANY**



ACEBOX

Space Age Electronics, Inc.
www.1sae.com
800.486.1723 Toll Free
508.485.0966 Local
508.485.4740 Fax



Features

- Nominal voltage 24VDC
- Unit is shipped with ANSI/UL1638 listed strobe or horn/strobe
- Super-Slide® - Ease of Supervision Testing
- Checkmate® - Instant Voltage Verification
- Switch selection for high or low dBA
- Switch for mechanical and 2400Hz tone
- Switch for continuous tone or temporal 3 (not available on whoop tone)
- Tamperproof re-entrant grill
- Prewire entire system, install mounting bracket, then install signals
- Separate horn and strobe functions
- Synchronize strobe and/or horn by using Potter AVSM Control Module
- Listed to ANSI/UL1638 when used with the WPBB or WPLPBB enclosure
- WPBB/WPLPBB made of clear Lexan® - provides maximum visibility and reliability for effective visible signaling - allowing full 75cd output
- Input terminals accept 12 to 18 AWG
- Faceplate available in red or off-white

Unit Dimensions

- WP Unit: 5.75" (14.605 cm) high x 4.75" (12.065 cm) wide x 4.18" (10.617 cm) deep
- LP Unit: 5.75" (14.605 cm) high x 4.75" (12.065 cm) wide x 3.25" (8.255 cm) deep



LISTED

S3247 Product includes a 5 year warranty

Description

The Outdoor Series offers dependable visible and/or audible alarms for all outdoor needs.

Included with the SLP/HSLP Series is the WPBB or WPLPBB outdoor enclosure. The enclosure is made of high quality Lexan® material, providing protection from weather related conditions and allowing the necessary full candela output. This highly constructed enclosure meets various installation requirements including deterring moisture from entering the enclosures.

The Outdoor Series is equipped with the 4" mounting plate which incorporates the Super-Slide® feature that allows the installer to easily test for supervision. The product also features a locking mechanism which secures the product to the bracket without any screws showing.

The Series also features the Checkmate® - Instant Voltage Verification feature which allows the installer to check the voltage drop draw and match it to ten blueprint.

The Series strobe has a minimal operating current and has a minimum flash rate of 1Hz regardless of input voltage.

The Series appliances are ANSI/UL 464 and ANSI/UL 1638 listed for use with fire protective systems and are warranted for three years from date of purchase.



Tone Switch Locations

| TONE | SWITCH POSITION | | |
|-------------------------|-----------------|-----|-----|
| | 3 | 4 | 5 |
| Mechanical Temporal 3 | ON | ON | ON |
| Mechanical - Continuous | OFF | ON | ON |
| 2400 Hz - Temporal 3 | ON | OFF | ON |
| 2400 Hz - Continuous | OFF | OFF | ON |
| Chime - Temporal 3 | ON | ON | OFF |
| Chime - Continuous | OFF | ON | OFF |
| Whoop | ON | OFF | OFF |
| Whoop | OFF | OFF | OFF |

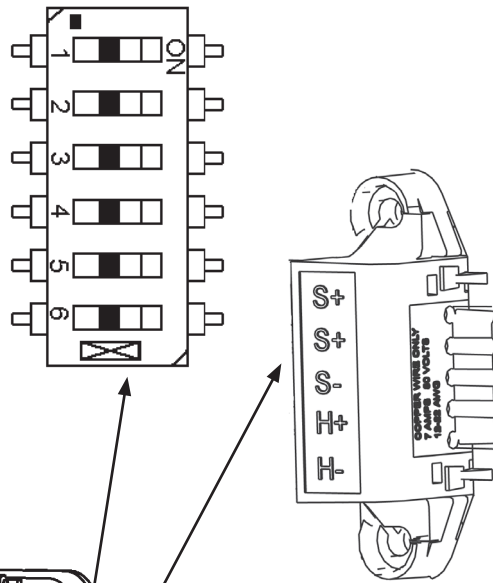

NOTE:

- Switch Positions 1 and 2 in the OFF position to select isolated horn and strobe power inputs
- Switch Position 6 ON = HIGH dBA
- Switch Position 6 OFF = LOW dBA

**Super-Slide®
Mounting Bracket**

Allows the installer to pre-wire the system, test for system supervision, remove the signal head until occupancy, switch out Gentex signals without changing mounting brackets and has locking edge connector for snap-in-place installation.

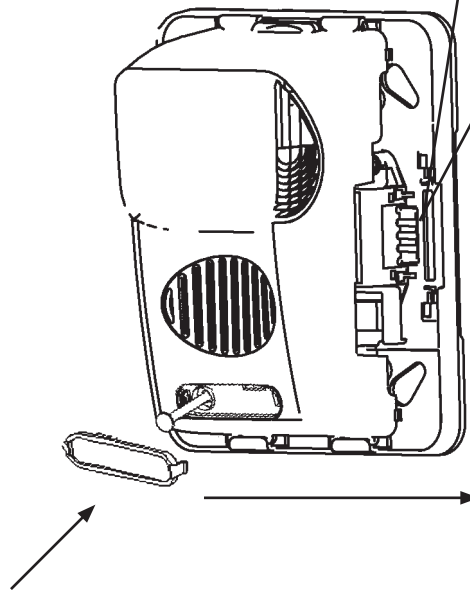

**Gentex Checkmate® Instant
Voltage Verification**

It is often necessary to confirm the voltage drop along a line of devices. The access holes are provided in the back of the terminal block to allow the voltage to be measured directly without removing the device. Typically this would be done at the end of the line to confirm design criteria. Most measurements will be taken using the S+ and S- locations although access is provided to other locations.

NOTE: Care should be taken to not short the test probes.

Mounting Outdoor Enclosure

Super-Slide® Mounting Plate:
Mounts to Outdoor Enclosure

Super-Slide® Mounting Plate:
Mounts to GOELP Outdoor Enclosure

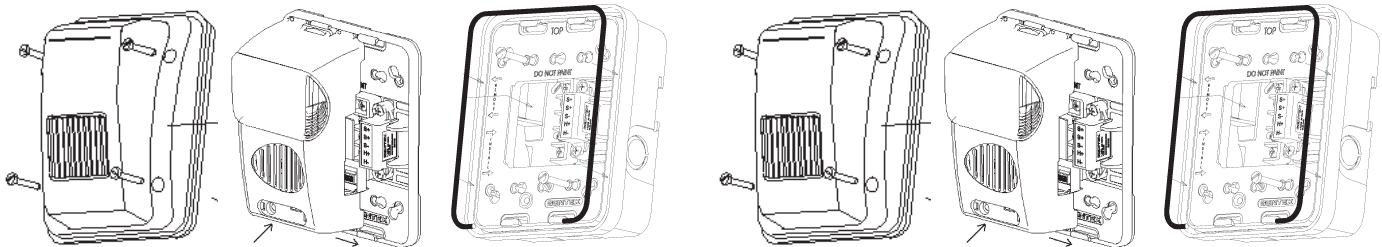



SLP24 Volt Outdoor Strobe

| Model Number | Part Number | Nominal Voltage | Candela (ANSI/UL 1638) | Shipping |
|--------------|-------------|-----------------|------------------------|---|
| S-24WR-WP | 4890050 | 24 VDC | 75 | Shipped with Weather Proof Back Box |
| S-24WW-WP | 4890051 | 24 VDC | 75 | |
| S-24PWR-WP | 4890052 | 24 VDC | 75 | |
| S-24PWW-WP | 4890053 | 24 VDC | 75 | |
| SLP-24WR-WP | 4890054 | 24 VDC | 75 | Shipped with Low Profile Weather Proof Back Box |
| SLP-24WW-WP | 4890055 | 24 VDC | 75 | |
| SLP-24PWR-WP | 4890056 | 24 VDC | 75 | |
| SLP-24PWW-WP | 4890057 | 24 VDC | 75 | |

Model Designations:

"W" = Wall Mount
"R" = Red Faceplate
"P" = Plain (no lettering)
"W" = Off-White Faceplate
NOTE: Plain units are non-returnable.
"LP" = Low Profile (WPLPBB Enclosure)

HS-24 Outdoor Horn/Strobe

| Model Number | Part Number | Nominal Voltage | Candela (ANSI/UL 1638) | Reverberant dBA @ 10 ft. per ANSI/UL 464 | In Anechoic Room dBA @ 10 ft. |
|--------------|-------------|-----------------|------------------------|--|-------------------------------|
| HS-24WR-WP | 4890060 | 24 VDC | 75 | 70-82 | 100 |
| HS-24WW-WP | 4890061 | 24 VDC | 75 | 70-82 | 100 |
| HS-24PWR-WP | 4890062 | 24 VDC | 75 | 70-82 | 100 |
| HS-24PWW-WP | 4890063 | 24 VDC | 75 | 70-82 | 100 |
| HSLP-24WR | 4890064 | 24 VDC | 75 | 70-82 | 100 |
| HSLP-24WW | 4890065 | 24 VDC | 75 | 70-82 | 100 |
| HSLP-24PWR | 4890066 | 24 VDC | 75 | 70-82 | 100 |
| HSLP-24PWW | 4890067 | 24 VDC | 75 | 70-82 | 100 |

| Horn Mode | Horn Decibel Levels | | Horn Current Ratings |
|-----------------------|---|--|---|
| | Minimum SPL at 10 feet per ANSI/UL 464 (HIGH) | Minimum SPL at 10 feet per ANSI/UL 464 (LOW) | Regulated 24 VDC Max. Operating at High Setting |
| Temp 3 2400 Hz | 78 dBA | 71* dBA | 28 mA |
| Temp 3 Mechanical | 76 dBA | 70* dBA | 25 mA |
| Temp 3 Chime | 70* dBA | 66* dBA | 15 mA |
| Continuous 2400 Hz | 81 dBA | 74* dBA | 28 mA |
| Continuous Mechanical | 80 dBA | 72* dBA | 25 mA |
| Continuous Chime | 70* dBA | 66* dBA | 15 mA |
| Whoop | 82 dBA | 69* dBA | 56 mA |

| WGE Series Product Strobe Current Ratings | |
|---|--------|
| Candela | 75 cd |
| 24 VDC | 112 mA |
| UL Max ¹ | 170 mA |

NOTES:

- The S-24 WP/HS-24 WP Series are listed for outdoor use. Indoor Operating Temperature: 32°F to 120°F (0°C to 49°C). Outdoor Operating Temperature: -31°F to 150°F (-35° C to 66°C).
- For nominal and peak current across ANSI/UL regulated voltage range for filtered DC power and unfiltered (FWR [Full Wave Rectified]) power, see installation manual.
- Potter does not recommend using a coded or pulsing signaling circuit with any of our strobe products.
- The sound output for the temporal 3 tone is rated lower since the time the horn is off is averaged into the sound output rating. While the horn is producing a tone in the temporal 3 mode its sound pressure is the same as the continuous mode.
- * Operating the horn in this mode at this voltage will result in not meeting the minimum UL reverberant sound level required for public mode fire protection service. These settings are acceptable only for private mode fire alarm use. Use the high dBA setting for public mode application (not applicable when using the chime tone. The chime tone is always private mode).

Architect & Engineering Specifications

The audible and/or visible signal shall be SLP/HSLP Series or approved equal and shall be listed by Underwriters Laboratories Inc. per ANSI/UL 1638 and/or ANSI/UL 464. The notification appliance shall also be listed with the California State Fire Marshal (CSFM).

The notification appliance (combination audible/visible) shall produce a peak sound output of 100dBA or greater at as measured in an anechoic chamber. The signaling appliance shall also have the capability to silence the audible signal while leaving the visible signal energized with the use of a single pair of power wires. Additionally, the user shall be able to select either continuous or temporal tone output with the temporal signal having the ability to be synchronized.

The audible/visible and visible signaling appliance shall also maintain a minimum flash rate of 1Hz or up to 2 Hz regardless of power input voltage. The appliance shall have an operating current of 170mA or less for the 75Cd strobe circuit. The appliance shall also be capable of meeting the candela requirements of the ADA (75cd).

The appliance shall be polarized to allow for electrical supervision of the system wiring. The unit shall be provided with a mounting bracket with terminals with barriers for input/output wiring and be able to mount to a single gang or double gang box or double workbox without the use of an adapter plate. The unit shall have an input voltage range of 16-33 volts with either direct current of full wave rectified power for 24 volt models.

The appliance shall be capable of testing supervision without disconnecting wires. Also the appliance shall be capable of mounting to a surface back box. The unit shall also be able to verify voltage at the unit without removing unit.

The appliance has extended temperature range of -31° to 150°F (-35° to 66° C). The appliance shall satisfy virtually all outdoor and severe environment applications. The Enclosure includes a gasket that must be inserted between the box and mounting bracket. There are drain holes in the back box to allow for drainage, the seal on the GOE Enclosure is not water tight. The LP Enclosure includes a weather seal for mounting to wall and intended for use with universal electrical box. To allow for drainage, bottom edge of enclosure is not water tight.

Conventional Wiring Diagrams for Emergency Notification Evacuation Series

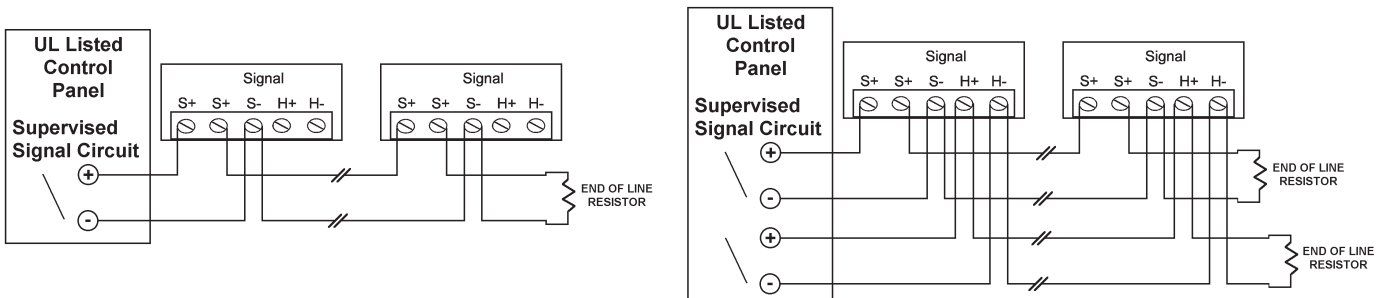

NOTES:

- All strobes are designed to flash as specified with continuous applied voltage. Strobes should not be used on coded or pulsing signaling circuits. However, use of the Potter AVSM control module or Gentex synchronization protocol is permitted to synchronize the strobe, horn and/or mute the horn.
- **FOR SYNCHRONIZATION WIRING INFORMATION, REFERENCE AVSM CONTROL MODULE DATA SHEET (8830050) AND/OR AVSM CONTROL MODULE MANUAL FOR SYNCHRONIZATION MODULE WIRING DIAGRAMS. AVSM CONTROL MODULE DATA SHEET AND MANUAL CAN BE OBTAINED AT <http://www.pottersignal.com> OR CALL POTTER ELECTRIC AT 1-800-325-3936.**



Reviewed for Code Compliance
 Permitting and Inspections Department
 Approved with Conditions
02/12/2020

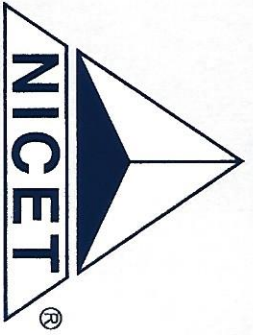

**NATIONAL INSTITUTE FOR CERTIFICATION
IN ENGINEERING TECHNOLOGIES®**

Providing Certification Programs Since 1961

BE IT KNOWN THAT

Richard W. Brobst, Jr

**IS HEREBY AWARDED CERTIFICATION AT
LEVEL IV**

**IN FIRE PROTECTION ENGINEERING TECHNOLOGY
FIRE ALARM SYSTEMS**

**BASED UPON SUCCESSFUL DEMONSTRATION OF REQUISITE KNOWLEDGE,
EXPERIENCE AND WORK PERFORMANCE AS SET FORTH BY THIS INSTITUTE.**

Certification Valid through October 1, 2020

CERTIFICATION NUMBER 106322

CHAIRMAN OF THE NICET BOARD OF GOVERNORS

A DIVISION OF THE NATIONAL SOCIETY OF PROFESSIONAL ENGINEERS



Reviewed for Code Compliance
Permitting and Inspections Department
Approved with Conditions

02/12/2020