

- REFLECTED CEILING PLAN NOTES**
- 1.) G.C. TO COORDINATE LOCATIONS OF PLUMBING CLEAN OUTS WITH ACCESS PANELS AS SHOWN ON REFLECTED CEILING PLANS
  - 2.) G.C. TO PROVIDE ACCESS PANELS AS REQUIRED FOR ALL ELEMENTS (SPRINKLER, VALVES, ETC) NOT SHOWN ON THIS REFLECTED CEILING PLAN)
  - 3.) G.C. TO PROVIDE METAL FRAMING AND BLOCKING REQUIRED FOR ALL ACCESS PANELS AND CONTROL JOINTS

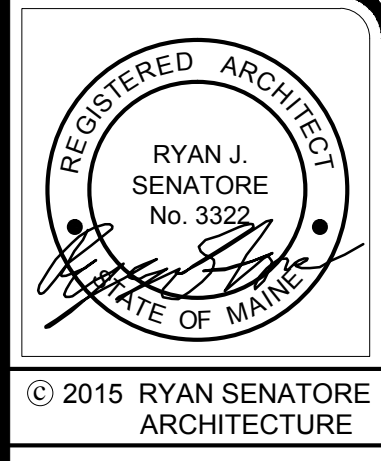

**APARTMENTS**  
**89 ANDERSON STREET**  
**PORTLAND, MAINE**

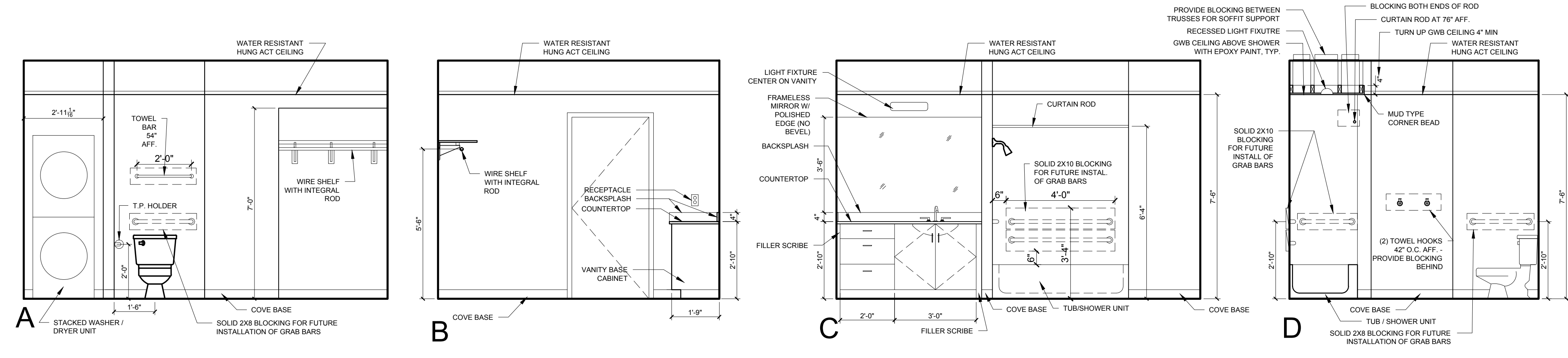

**4 BATHROOM ELEVATIONS**  
 3/8" = 1'-0"

- UNIT NOTES**
- 1.) CEILING HEIGHTS, WINDOW HEAD AND SILL HEIGHTS VARY FROM FLOOR TO FLOOR. INTERIOR ELEVATIONS GRAPHICALLY DEPICT ONE FLOOR ONLY. FOR HEIGHT INFORMATION REFER TO BUILDING SECTIONS AND WALL SECTIONS
  - 2.) G.C. TO CONFIRM AND COORDINATE ALL ROUGH FRAMING DIMENSIONS FOR TUBS, SHOWERS, BUILT-IN FIXTURES ETC. G.C. TO CONFIRM AND COORDINATE ALL CABINETRY AND APPLIANCE DIMENSIONS
  - 3.) PROVIDE APPROPRIATE BLOCKING IN WALLS BEHIND ALL FIXTURES, PARTITIONS AND ACCESSORIES. BLOCKING FOR GRAB BARS TO BE PROVIDED IN WALLS OF BATHROOMS IN ALL UNITS
  - 4.) PROVIDE MOISTURE RESISTANT GWB AT ALL WALLS AND CEILINGS IN BATHROOMS TYPICAL
  - 5.) SET ALL CLOTHES WASHERS IN PANS WITH WATER SENSOR
  - 6.) REFER TO ELECTRICAL AND MECHANICAL DRAWINGS FOR ADDITIONAL INFORMATION REGARDING LIGHTING, DIFFUSERS, ETC.
  - 7.) PROVIDE FIRE EXTINGUISHER ON BRACKET IN BASE CABINET BELOW KITCHEN SINK - TYPICAL
  - 8.) HANG HOT WATER HEARER FROM CEILING ABOVE CLOTHES ROD IN CLOSET. PROVIDE UNISTRUT SUPPORTS ON TOP OF BOTTOM CHORDS OF TRUSSES PRIOR TO CEILING INSTALLATION
  - 9.) WHERE DROPPED SOFFITS AND CEILINGS ARE SHOWN, THESE ARE IN ADDITION TO THE FIRE RATED GWB CEILING ABOVE WHICH IS PART OF THE RATED ASSEMBLY
  - 10.) WHERE PLUMBING VALVES (TUB, SHOWER, ETC) ARE LOCATED IN FIRE RATED WALLS, PROVIDE FIRE RATED BOX IN WALL FOR VALVE TO BE INSTALLED WITHIN

**RSA**

**RYAN SENATORE ARCHITECTURE**  
 565 CONGRESS STREET  
 PORTLAND, MAINE 04101  
 207-650-6414  
 senatorearchitecture.com

**CONSULTANTS:**

**STRUCTURAL:**  
**Structural Integrity**  
 77 Oak Street  
 Portland, ME 04101  
 207-774-4614

**CABINETRY AND APPLIANCE ABBREVIATIONS**

DB	= DRAWER BASE
DRB	= DOOR BASE
SB	= SINK BASE
WC	= WALL CABINET
WC(24)	= WALL CABINET 24" DEEP
PU	= PANTRY UNIT 24" DEEP
OS	= OPEN SHELVES
RA	= RANGE
DW	= DISHWASHER
REF	= REFRIGERATOR

**REFLECTED CEILING PLAN AND LIGHTING LEGEND**

SYMBOL	TAG	DESCRIPTION
●	A	TROSS IKEA SURFACE MOUNT
○	B	SURFACE MOUNTED - TBD
○	C	SURFACE MOUNT - IN CLOSETS
○	D	SURFACE MOUNTED ON WALL ABOVE DOOR
○	E	WALL SCONCE IN BATHROOM OVER VANITY
○	F	SURFACE MOUNT - WET LOCATION
○	H	SURFACE MOUNT CENTER IN BEDROOMS
○	J	RECESSED DOWN LIGHT - WET LOCATION
○	K	EXTERIOR CUT OFF DOWN LIGHT
○	L	RECESSED CAN LIGHT FIXTURE
■		CEILING GRILLE

**REVISIONS:**

DATE: JULY 3, 2015  
 PROJECT No. 1415  
 DRAWN BY: RRT / RJS  
 CHECKED BY: RJS  
 SCALE: AS NOTED

SHEET TITLE:  
**UNIT 212, 312 AND 412 PLANS AND INTERIOR ELEVATIONS**

**A1-18**

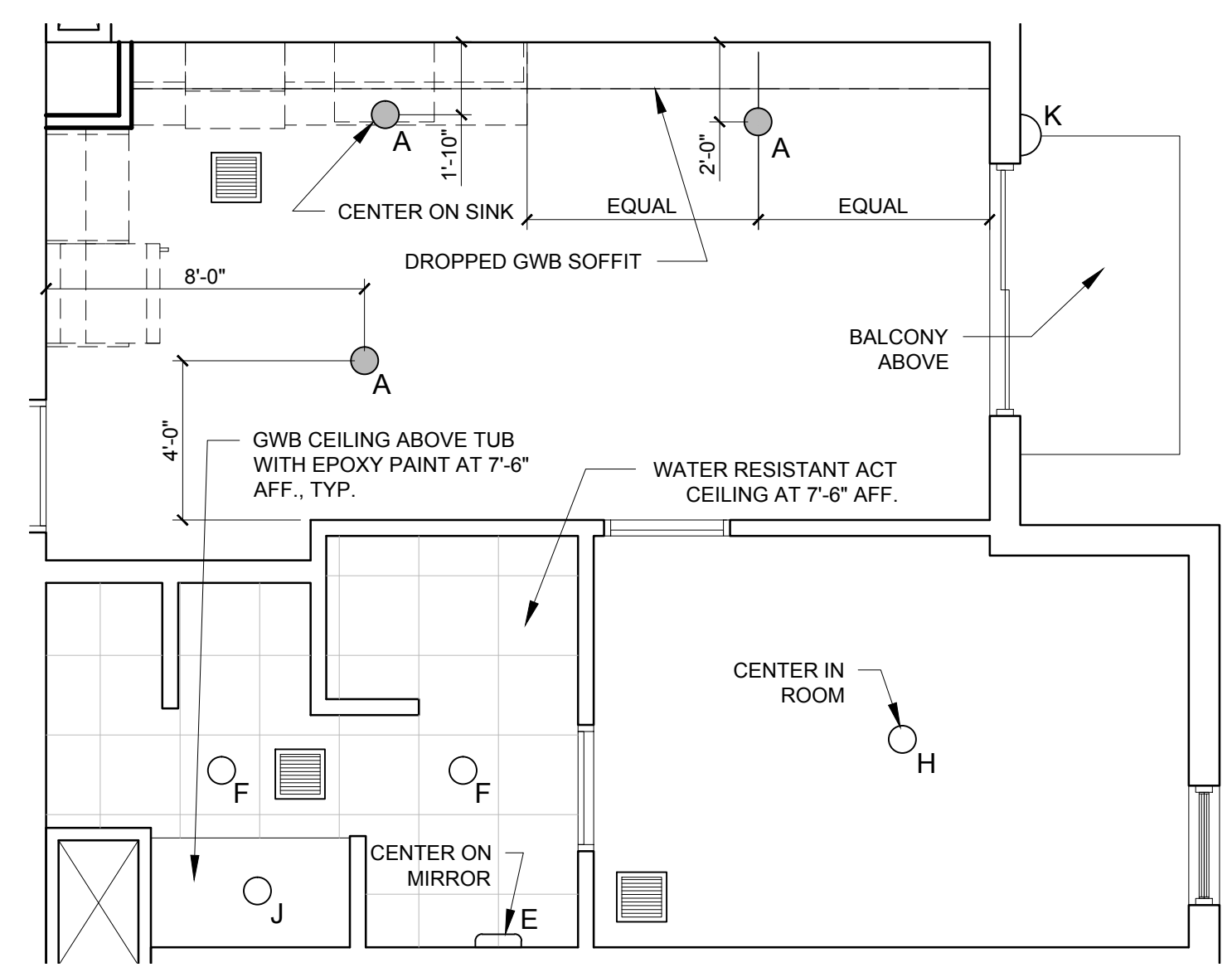

**2 UNITS 212, 312 AND 412 REFLECTED CEILING PLAN**  
 1/4" = 1'-0"

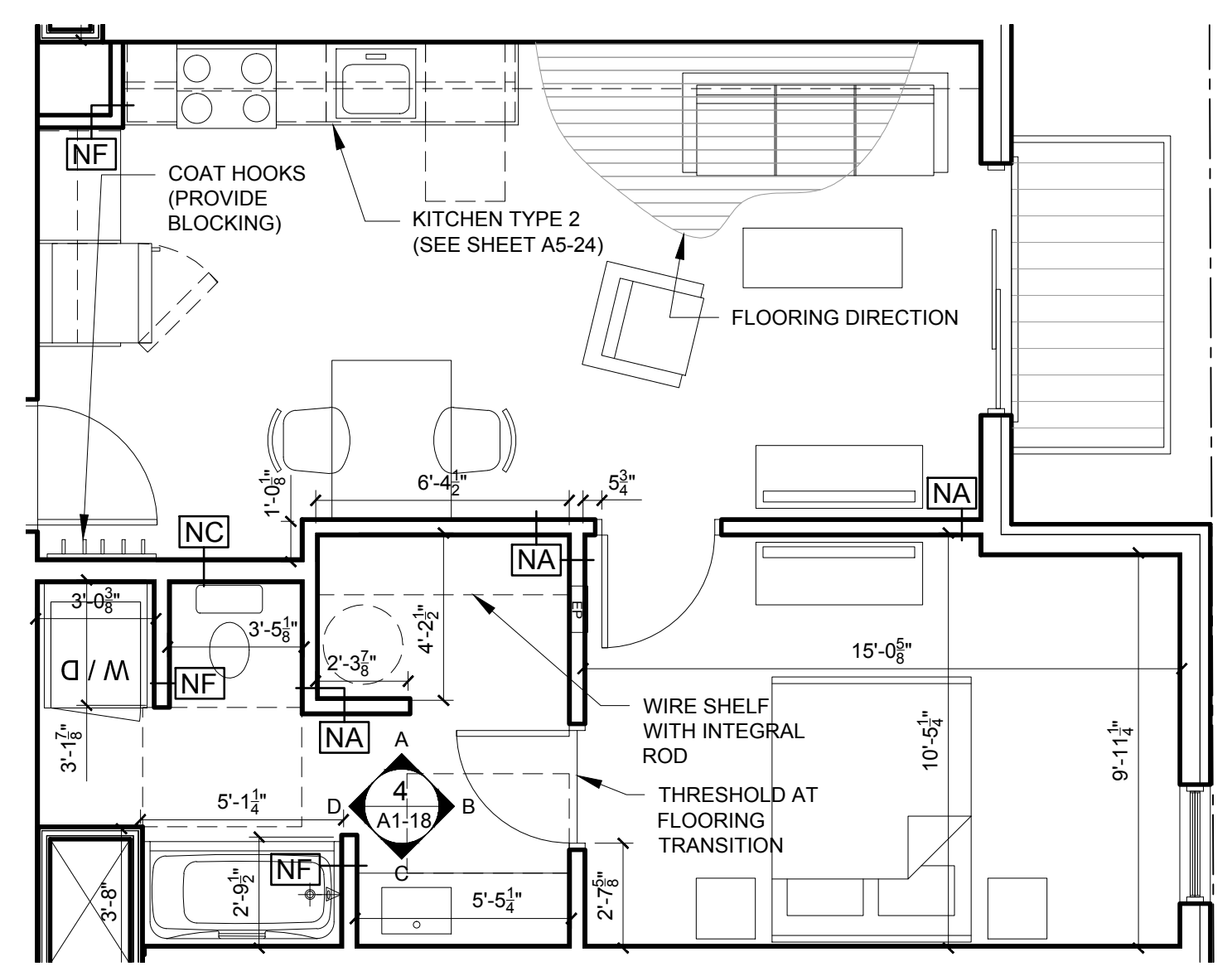

**1 UNITS 212, 312 AND 412 FLOOR PLAN**  
 1/4" = 1'-0"