

POST CONSTRUCTION - STORMWATER INSPECTION & MAINTENANCE PLAN

Prepared For:

**Redfern Munjoy, LLC
Munjoy Heights
79 Walnut Street
Portland, Maine 04101**

Prepared By:

**Acorn Engineering, Inc.
PO Box 3372
Portland, Maine 04104**

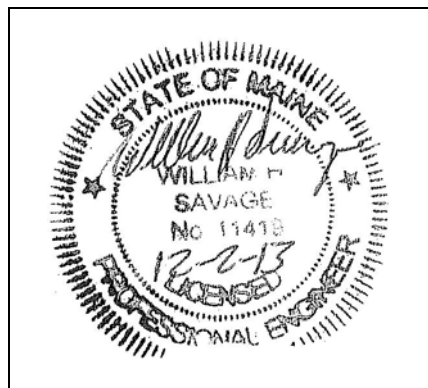

**November 2013
Revised: 1/16/14**

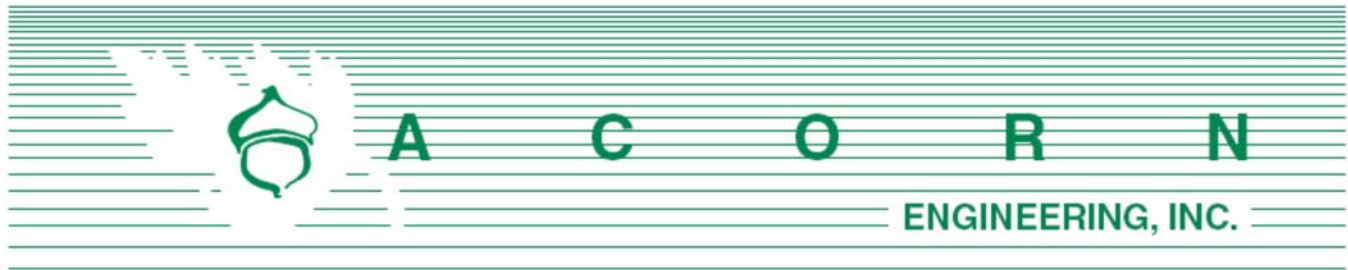

RESPONSIBLE PARTY

The owner, Redfern Munjoy, LLC, and or their successor shall be responsible for contracting with a qualified stormwater professional to implement the Inspection and Maintenance Plan. The qualified stormwater professional shall maintain a stormwater log (report) summarizing inspections, maintenance, and corrective action taken. The Qualified Stormwater Professional shall annually submit the Stormwater Log to the Department of Public Services prior to June 30th.

The following is an example of a qualified stormwater professional that the homeowners association may contract through.

Organization: Will Savage, PE
Acorn Engineering, Inc
Portland, Maine

Phone: (207) 775-2655

Qualifications:

- Maine Professional Engineering License #11419
- Maine DEP - Certified in Maintenance & Inspection of Stormwater BMP's Cert #14
- Certified Erosion, Sediment and Storm Water Inspector (CESSWI) Cert #0293
- Certified Professional in Erosion and Sediment Control (CPESC) Cert. #4620

The inspection and maintenance criteria is based upon the Maine DEP - Stormwater Management for Maine, Volume III: BMPs Technical Design Manual. Refer to the Grading and Drainage Plan for the location of the BMPs

PURPOSE

This Inspection and Maintenance Plan has been individually tailored to this parcel's stormwater infrastructure, site characteristics, and their respective opportunities and limitations related to reducing the pollutant load on the receiving watershed. The maintenance of a parcel's impervious surfaces and stormwater infrastructure is critical to extending the long term performance and effectiveness of Best Management Practices (BMPs). The Inspection and Maintenance Plan represents the parcel's minimum activities to meet the permit requirements. The parcel shall still be subject to any applicable Civil Site Plans, Permit Applications, Erosion and Sedimentation Control Plans Reports, Stormwater Management Plans, Inspection and Maintenance Manuals, and all Municipal, State, and Federal rules.

OPERATION AND MAINTENANCE ACTIVITY

Underdrained Subsurface Sand Filter (USSF):

The maintenance of the underdrained subsurface sand filter shall be in accordance with the following activities identified below and the most recent version of the Maine DEP Volume III BMPs Technical Design Manual Chapter 7.3 Underdrained Subsurface Sand Filter.

- The system should be inspected after every major storm in the first few months to ensure proper function. Thereafter, the filter should be inspected at least once every six months to ensure that it is draining within 24 hours to 36 hours.
- Inspect Outlet Control Structures (OCS) to ensure they are in good working order and that the orifice and trash racks are unobstructed from trash and debris.
- Inspect and maintain the StormTech Isolator Row in accordance with the attached proprietary Operation and Maintenance Plan.

Sweeping:

Annual sweeping of the driveway and parking areas following the snow melt for accumulated winter sand, if necessary. Appropriately dispose of all collected material.

Storm Drains:

The storm drain shall be annually inspected for the presence of accumulated sediment or debris. Any sediment shall be removed as required.

- The equipment shall meet the following minimum specifications; power jet and water source for washing down the storm drain, vacuum attachment for catch basin cleaning, and a liquid handling method to dewater the material.
- Inspect and legally dispose of accumulated sediment and debris within the storm drains between basins. Liquids must be decanted on-site and returned to the catch basin.

Catch Basins:

Catch basins shall be inspected to confirm the structure is operating properly.

- Inspect the presence of accumulated sediment or debris any sediment shall be removed. The equipment shall meet the following minimum specifications; power jet and water source for washing down the storm drain, vacuum attachment for catch basin cleaning, and a liquid handling method to dewater the material.
- Sediment shall be removed when accumulation is within 6 inches of the outfall pipe invert. Legally dispose of accumulated sediment and debris from the bottom of the basin, inlet grates, and inflow channels to the basin.
- If the basin outlet is designed with a hood to trap floatable materials (e.g. Snout), check to ensure watertight seal is working.
- Appropriately dispose of all collected material.

Rain Garden (Bioretention Cell):

The maintenance of the rain garden shall be in accordance with the following activities identified below and the most recent version of the Maine DEP Volume III BMPs Technical Design Manual Chapter 7.2 Underdrained Bioretention Cell BMP.

- The soil filter shall be inspected to ensure the filter area is draining within a 48-hour period and no less than a 24-hour period.
- Soil filter replacement shall occur when water ponds on the surface of the bed for periods greater than 72 hours. The top several inches of the filter shall be replaced with fresh material. Removed material shall be disposed in an acceptable manner.
- Soil filter modification shall occur if the filter bed is draining in less than 24 hours. The top six inches of the filter shall be replaced with six inches of loam, per the most recent Maine DEP specification.
- The filter area shall not be fertilized unless it is absolutely necessary.
- Harvesting and pruning of excessive growth shall be done occasionally. Weeding to control unwanted or invasive plants may be necessary.
- Inspect the overflow outlet to ensure they are in good working order and unobstructed from trash and debris.

Landscaped, Vegetated and Areas Adjacent to Retaining Walls:

Inspect all landscaped and or vegetated slopes and embankments on an annual basis. Vegetated areas with bare areas or sparse growth (<90% coverage) shall be revegetated. Mulch shall be applied to landscaped areas, as necessary. Dead or decaying landscaping (ground cover, shrubs, trees etc.) shall be replanted in accordance with the approved Landscape Plan by Soren Deniord Design Studios.

If signs of rill erosion or scour are present within areas tributary to the retaining walls, or stormwater flow is observed flowing over the wall, Acorn Engineering should be immediately contacted to perform an inspection and/or to contact the appropriate professional. Should concerns arise from the downhill abutters related to groundwater flow from the retaining wall weep hole outlets, Acorn Engineering should be contacted to perform a site inspection and to meet with the concerned abutter. Periodic inspections of the retaining walls shall be performed, under separate contract, by a Professional Geotechnical Engineer.

INSPECTION AND MAINTENANCE TABLE

| Inspection and Maintenance Frequency | Spring or Yearly | Summer | Fall | As Necessary |
|---|-------------------------|---------------|-------------|---------------------|
| Underdrained Subsurface Sand Filter | X | | X | X |
| Sweeping | X | | | X |
| Storm Drains | | X | | X |
| Catch Basins | | X | | X |
| Rain Garden | X | X | | X |
| Landscaped/Vegetated/Wall Areas | X | | | X |

**Save Valuable Land and
Protect Water Resources**



Isolator[®] Row O&M Manual
StormTech[®] Chamber System for Stormwater Management

1.0 The Isolator[®] Row

1.1 INTRODUCTION

An important component of any Stormwater Pollution Prevention Plan is inspection and maintenance. The StormTech Isolator Row is a patented technique to inexpensively enhance Total Suspended Solids (TSS) removal and provide easy access for inspection and maintenance.



Looking down the Isolator Row from the manhole opening, woven geotextile is shown between the chamber and stone base.

1.2 THE ISOLATOR ROW

The Isolator Row is a row of StormTech chambers, either SC-310, SC-310-3, SC-740, DC-780, MC-3500 or MC-4500 models, that is surrounded with filter fabric and connected to a closely located manhole for easy access. The fabric-wrapped chambers provide for settling and filtration of sediment as storm water rises in the Isolator Row and ultimately passes through the filter fabric. The open bottom chambers and perforated sidewalls (SC-310, SC-310-3 and SC-740 models) allow storm water to flow both vertically and horizontally out of the chambers. Sediments are captured in the Isolator Row protecting the storage areas of the adjacent stone and chambers from sediment accumulation.

Two different fabrics are used for the Isolator Row. A woven geotextile fabric is placed between the stone and the Isolator Row chambers. The tough geotextile provides a media for storm water filtration and provides a durable surface for maintenance operations. It is also designed to prevent scour of the underlying stone and remain intact during high pressure jetting. A non-woven fabric is placed over the chambers to provide a filter media for flows passing through the perforations in the sidewall of the chamber. The non-woven fabric is not required over the DC-780, MC-3500 or MC-4500 models as these chambers do not have perforated side walls.

The Isolator Row is typically designed to capture the “first flush” and offers the versatility to be sized on a volume basis or flow rate basis. An upstream manhole not only provides access to the Isolator Row but typically includes a high flow weir such that storm water flowrates or volumes that exceed the capacity of the Isolator Row overtop the over flow weir and discharge through a manifold to the other chambers.

The Isolator Row may also be part of a treatment train. By treating storm water prior to entry into the chamber system, the service life can be extended and pollutants such as hydrocarbons can be captured. Pre-treatment best management practices can be as simple as deep sump catch basins, oil-water separators or can be innovative storm water treatment devices. The design of the treatment train and selection of pretreatment devices by the design engineer is often driven by regulatory requirements. Whether pretreatment is used or not, the Isolator Row is recommended by StormTech as an effective means to minimize maintenance requirements and maintenance costs.

Note: See the StormTech Design Manual for detailed information on designing inlets for a StormTech system, including the Isolator Row.

StormTech Isolator Row with Overflow Spillway (not to scale)

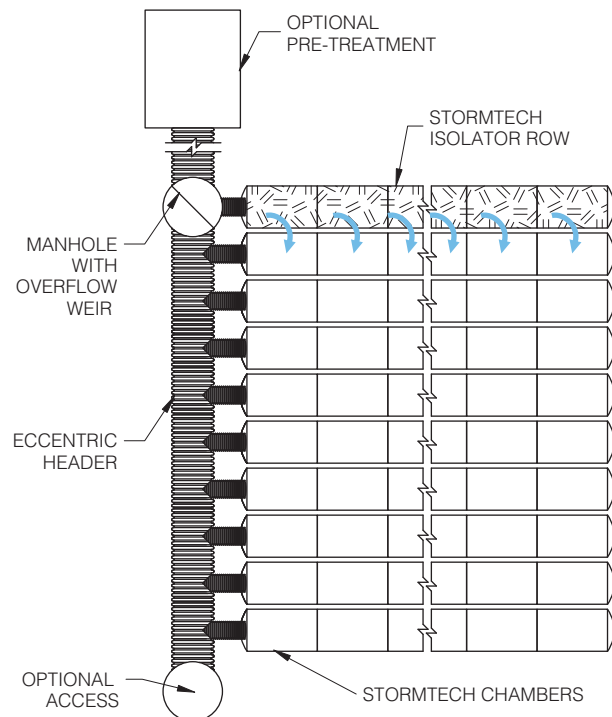

2.0 Isolator Row Inspection/Maintenance



2.1 INSPECTION

The frequency of Inspection and Maintenance varies by location. A routine inspection schedule needs to be established for each individual location based upon site specific variables. The type of land use (i.e. industrial, commercial, residential), anticipated pollutant load, percent imperviousness, climate, etc. all play a critical role in determining the actual frequency of inspection and maintenance practices.

At a minimum, StormTech recommends annual inspections. Initially, the Isolator Row should be inspected every 6 months for the first year of operation. For subsequent years, the inspection should be adjusted based upon previous observation of sediment deposition.

The Isolator Row incorporates a combination of standard manhole(s) and strategically located inspection ports (as needed). The inspection ports allow for easy access to the system from the surface, eliminating the need to perform a confined space entry for inspection purposes.

If upon visual inspection it is found that sediment has accumulated, a stadia rod should be inserted to determine the depth of sediment. When the average depth of sediment exceeds 3 inches throughout the length of the Isolator Row, clean-out should be performed.

2.2 MAINTENANCE

The Isolator Row was designed to reduce the cost of periodic maintenance. By “isolating” sediments to just one row, costs are dramatically reduced by eliminating the need to clean out each row of the entire storage bed. If inspection indicates the potential need for maintenance, access is provided via a manhole(s) located on the end(s) of the row for cleanout. If entry into the manhole is required, please follow local and OSHA rules for a confined space entries.



Examples of culvert cleaning nozzles appropriate for Isolator Row maintenance. (These are not StormTech products.)

Maintenance is accomplished with the JetVac process. The JetVac process utilizes a high pressure water nozzle to propel itself down the Isolator Row while scouring and suspending sediments. As the nozzle is retrieved, the captured pollutants are flushed back into the manhole for vacuuming. Most sewer and pipe maintenance companies have vacuum/JetVac combination vehicles. Selection of an appropriate JetVac nozzle will improve maintenance efficiency. Fixed nozzles designed for culverts or large diameter pipe cleaning are preferable. Rear facing jets with an effective spread of at least 45” are best. Most JetVac reels have 400 feet of hose allowing maintenance of an Isolator Row up to 50 chambers long. **The JetVac process shall only be performed on StormTech Isolator Rows that have AASHTO class 1 woven geotextile (as specified by StormTech) over their angular base stone.**

StormTech Isolator Row (not to scale)

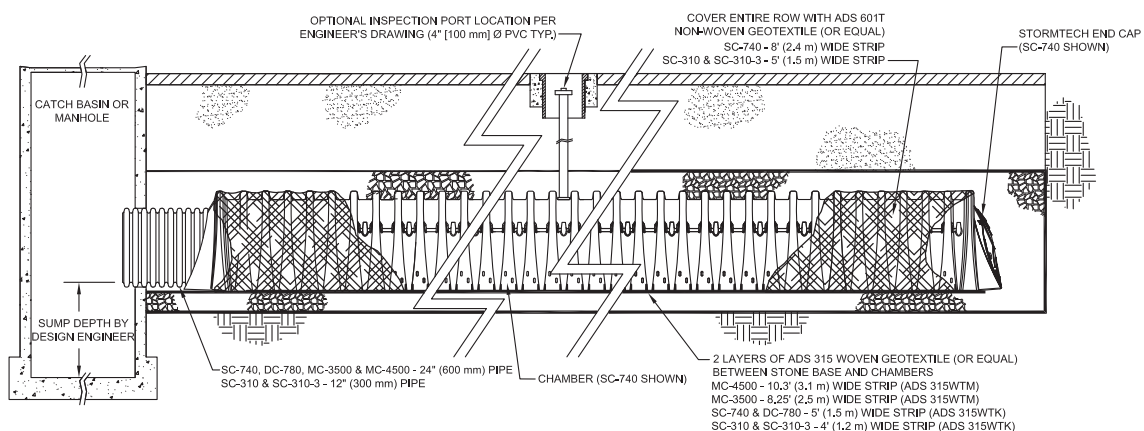

NOTE: NON-WOVEN FABRIC IS ONLY REQUIRED OVER THE INLET PIPE CONNECTION INTO THE END CAP FOR DC-780, MC-3500 AND MC-4500 CHAMBER MODELS AND IS NOT REQUIRED OVER THE ENTIRE ISOLATOR ROW.

3.0 Isolator Row Step By Step Maintenance Procedures

Step 1) Inspect Isolator Row for sediment

- A) Inspection ports (if present)
 - i. Remove lid from floor box frame
 - ii. Remove cap from inspection riser
 - iii. Using a flashlight and stadia rod, measure depth of sediment and record results on maintenance log.
 - iv. If sediment is at, or above, 3 inch depth proceed to Step 2. If not proceed to step 3.
- B) All Isolator Rows
 - i. Remove cover from manhole at upstream end of Isolator Row
 - ii. Using a flashlight, inspect down Isolator Row through outlet pipe
 1. Mirrors on poles or cameras may be used to avoid a confined space entry
 2. Follow OSHA regulations for confined space entry if entering manhole
 - iii. If sediment is at or above the lower row of sidewall holes (approximately 3 inches) proceed to Step 2. If not proceed to Step 3.

StormTech Isolator Row (not to scale)

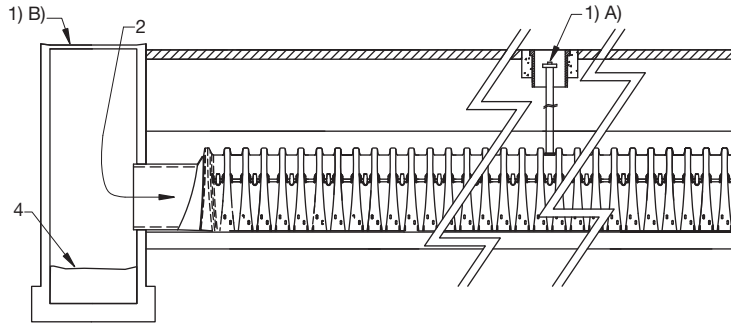

Step 2) Clean out Isolator Row using the JetVac process

- A) A fixed culvert cleaning nozzle with rear facing nozzle spread of 45 inches or more is preferable
- B) Apply multiple passes of JetVac until backflush water is clean
- C) Vacuum manhole sump as required

Step 3) Replace all caps, lids and covers, record observations and actions

Step 4) Inspect & clean catch basins and manholes upstream of the StormTech system

Sample Maintenance Log

| Date | Stadia Rod Readings | | Sediment Depth (1) - (2) | Observations/Actions | Inspector |
|---------|-----------------------------------|------------------------------------|--------------------------|--|-----------|
| | Fixed point to chamber bottom (1) | Fixed point to top of sediment (2) | | | |
| 3/15/01 | 6.3 ft. | none | | New installation. Fixed point is CI frame at grade | djm |
| 9/24/01 | | 6.2 | 0.1 ft. | Some grit felt | sm |
| 6/20/03 | | 5.8 | 0.5 ft. | Mucky feel, debris visible in manhole and in Isolator row, maintenance due | rv |
| 7/7/03 | 6.3 ft. | | 0 | System jetted and vacuumed | djm |



70 Inwood Road, Suite 3 | Rocky Hill | Connecticut | 06067
 860.529.8188 | 888.892.2694 | fax 866.328.8401 | www.stormtech.com

ADS "Terms and Conditions of Sale" are available on the ADS website, www.ads-pipe.com
 Advanced Drainage Systems, the ADS logo, and the green stripe are registered trademarks of Advanced Drainage Systems.
 Stormtech® and the Isolator® Row are registered trademarks of StormTech, Inc.
 Green Building Council Member logo is a registered trademark of the U.S. Green Building Council.