

COPYRIGHT: Reuse or reproduction of the contents of this document is not permitted without written permission of Bild Architecture LLC

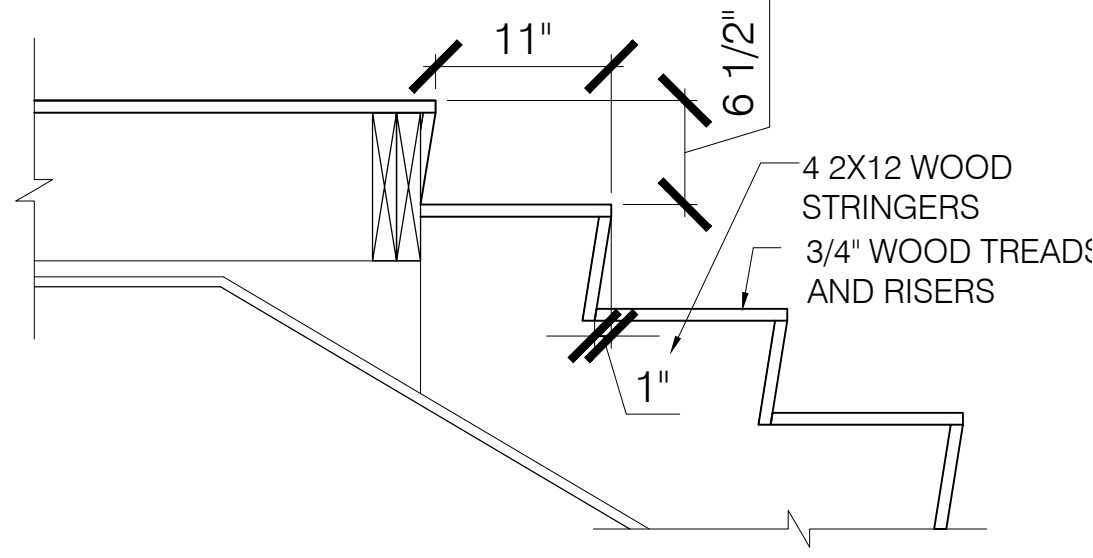

1 RISER/TREAD DETAIL - TYP.  
SCALE: 1" = 1'-0"

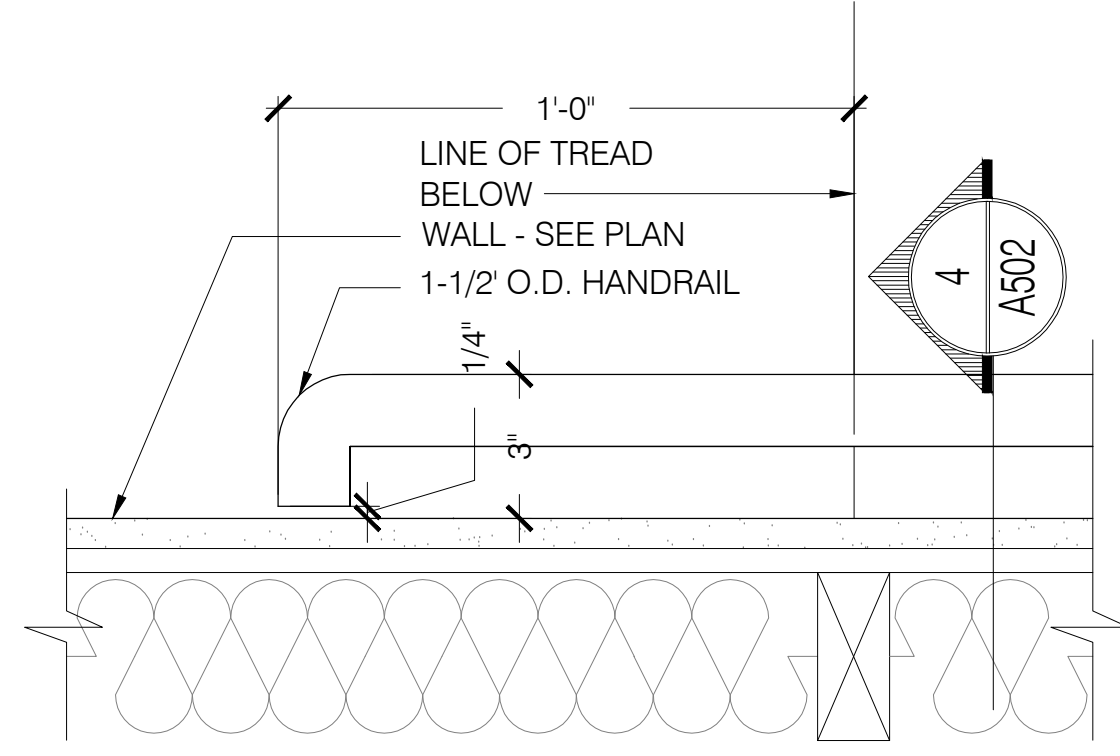

2 INTERIOR HANDRAIL DETAIL  
SCALE: 3" = 1'-0"

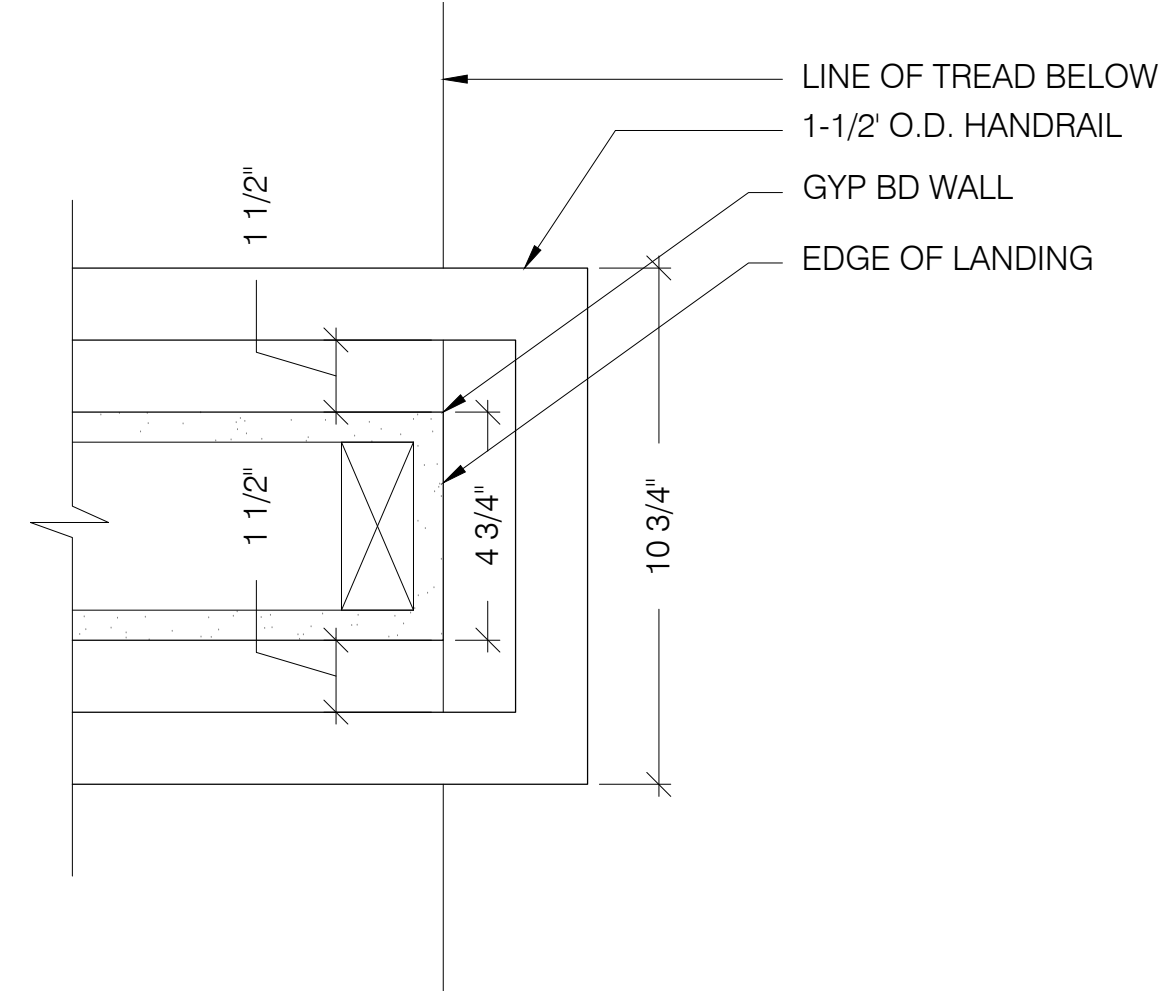

3 HANDRAIL SWITCHBACK DETAIL  
SCALE: 3" = 1'-0"

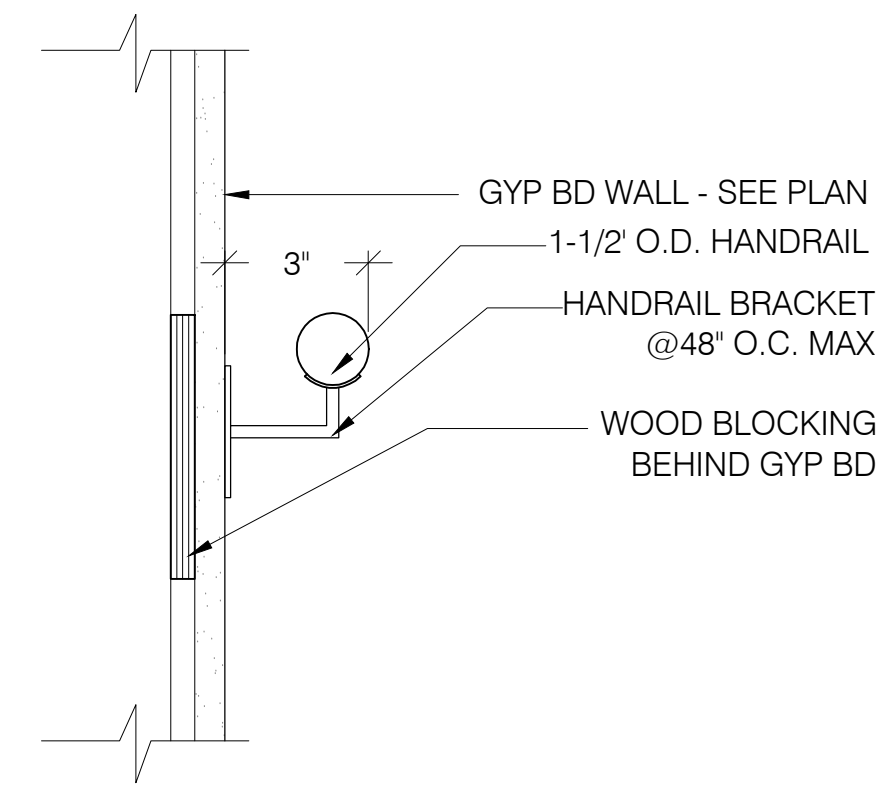

4 HANDRAIL SECTION DETAIL  
SCALE: 3" = 1'-0"

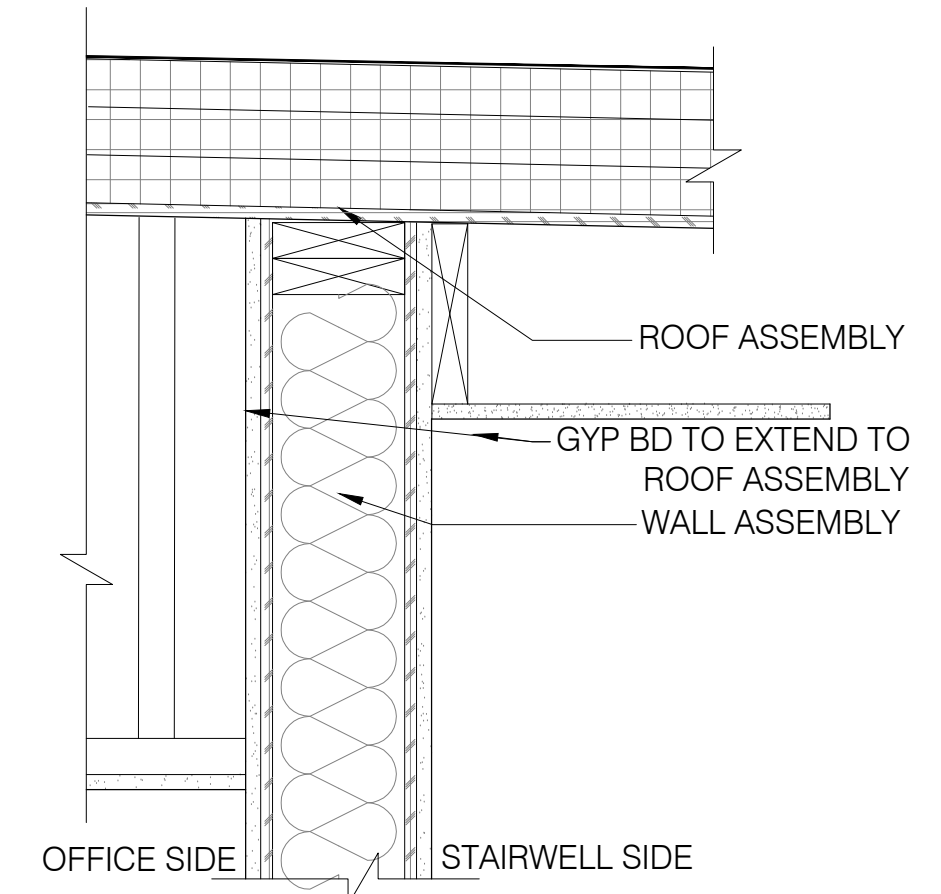

5 T.O. WALL @ STAIR SHAFT  
SCALE: 1 1/2" = 1'-0"

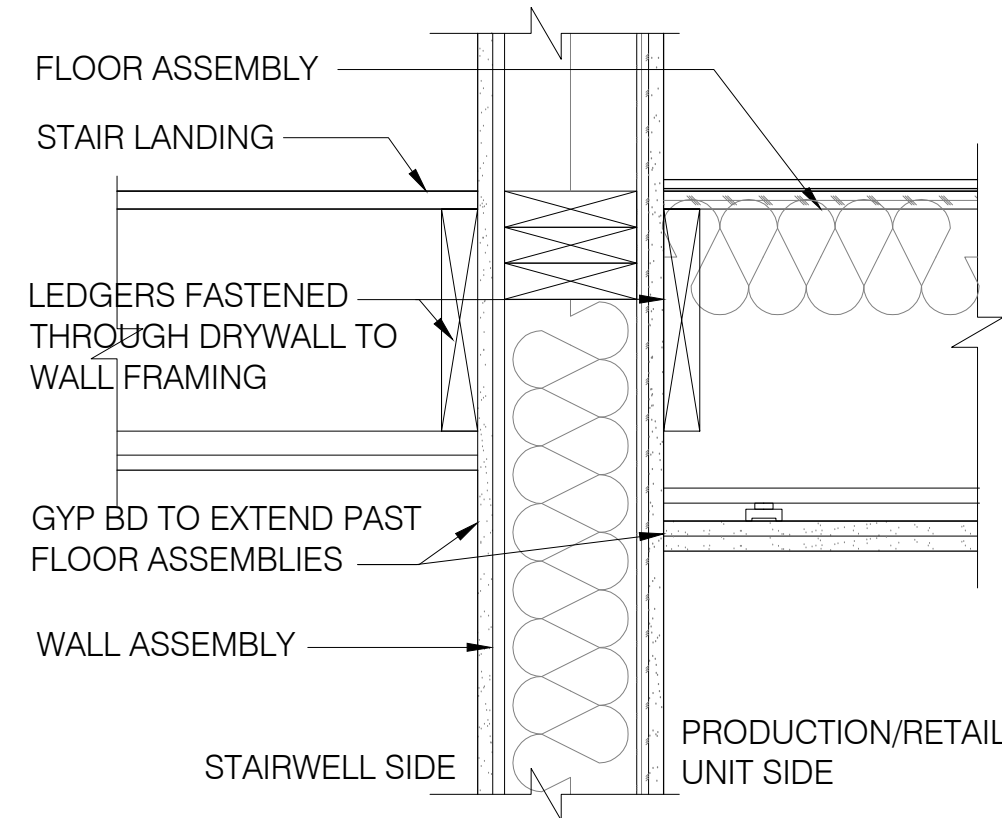

6 RATED WALL STAIR/UNIT  
SCALE: 1 1/2" = 1'-0"

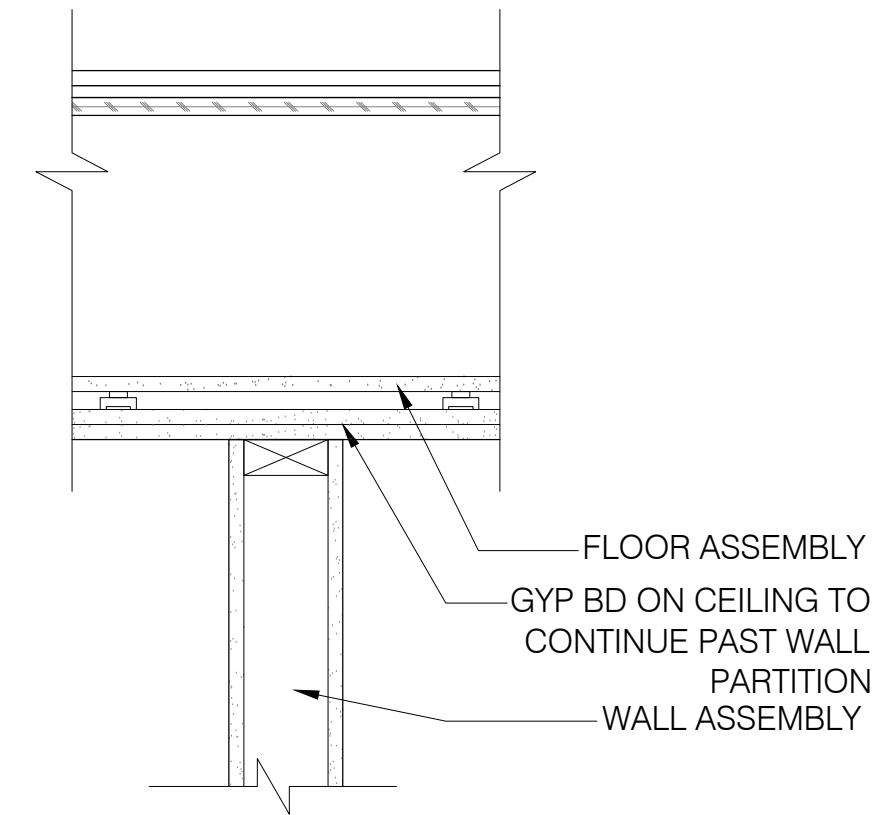

7 T.O. WALL PARTITION  
SCALE: 1 1/2" = 1'-0"

8 X  
SCALE: 3" = 1'-0"

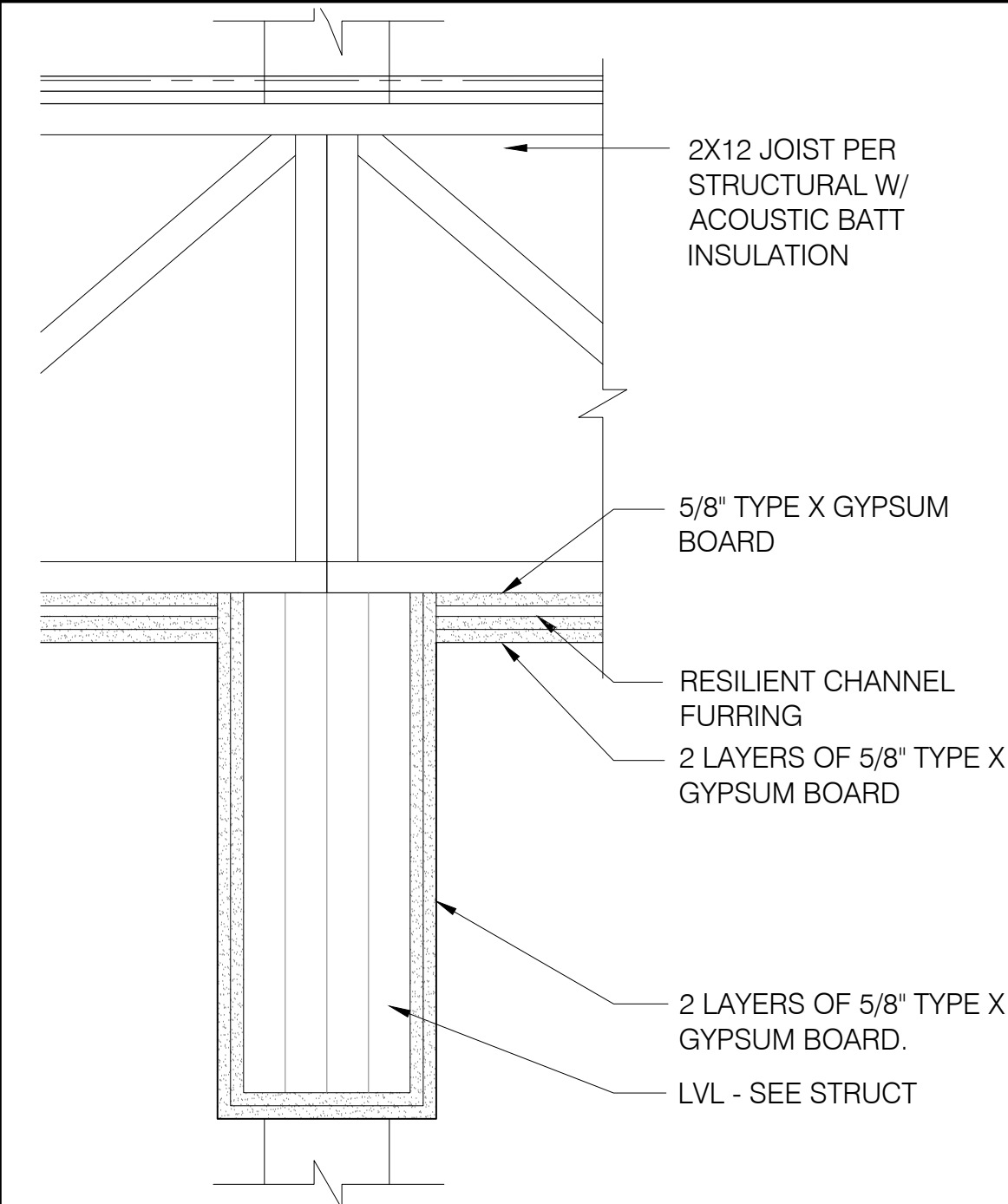

9 LVL WRAP DETAIL  
SCALE: 1 1/2" = 1'-0"

ISSUE DATE  
**2/2/18**  
SHEET SCALE  
N.T.S.

DRAWN BY  
**EMW**  
SHEET TITLE

**DETAILS**

REVISIONS

1	-
2	-
3	-
4	-
5	-

PROJECT NO.  
**16040**

PROJECT NAME

**MIXED-USE SHELL**

50 COVE STREET, PORTLAND ME - 04101



**Bild Architecture**  
PO Box 8235  
Portland, ME  
04104  
207.408.0168  
evan@bildarchitecture.com

**A**

5.2