

GENERAL NOTES

1. CONSULT ARCHITECTURAL, MECHANICAL, ELECTRICAL, PLUMBING, AND SITE DRAWINGS FOR LOCATIONS AND DIMENSIONS OF OPENINGS, CHASES, INSERTS, REGLETS, SLEEVES, DEPRESSIONS, AND OTHER DETAILS NOT SHOWN ON STRUCTURAL DRAWINGS.
2. ALL DIMENSIONS AND CONDITIONS MUST BE VERIFIED IN THE FIELD. ANY DISCREPANCIES SHALL BE BROUGHT TO THE ATTENTION OF THE ENGINEER BEFORE PROCEEDING WITH THE AFFECTED PART OF THE WORK.
3. THE CONTRACTOR IS RESPONSIBLE FOR THE STABILITY OF THE STRUCTURE DURING ALL PHASES OF ERECTION AND CONSTRUCTION.
4. DETAILS SHOWN AS "TYPICAL" APPLY TO ALL SIMILAR CONDITIONS.
5. COORDINATION FOR THE PROPER INSTALLATION OF FINISHES, ELECTRICAL, MECHANICAL, AND ALL OTHER NON-STRUCTURAL ELEMENTS IN THE BUILDING IS THE RESPONSIBILITY OF OTHERS. WATERPROOFING AND INSULATION DETAILS SHALL BE PROVIDED BY OTHERS.
6. DESIGN AND DETAILING OF ALL MASONRY IS THE RESPONSIBILITY OF OTHERS UNLESS SPECIFICALLY NOTED ON THE DRAWINGS.
7. IT IS THE RESPONSIBILITY OF THE GENERAL CONTRACTOR TO ADEQUATELY PROTECT ALL MATERIALS AND ASSEMBLIES FROM WEATHER DURING CONSTRUCTION. G.C. VERIFY MOISTURE CONTENT OF ALL SUB-BASE MATERIALS BEFORE INSTALLATION OF FINISHES; INSTALL ALL FINISHES PER MANUFACTURERS' INSTRUCTIONS.
8. STAIR DESIGN BY OTHERS, UNO

FOUNDATION NOTES

1. PREPARE ALL SOILS IN ACCORDANCE WITH THE SPECIFICATION OF THE GEOTECHNICAL REPORT #1212 BY SUMMIT GEOENGINEERING.
2. THE BOTTOM OF ALL EXTERIOR FOOTINGS SHALL BE AT LEAST 48" BELOW FINISH GRADE. GC COORDINATE FOOTING STEP LOCATIONS WITH FINISH GRADES AND SLAB ELEVATIONS TO ENSURE MINIMUM FROST COVERAGE. REINFORCE WALL AND FOOTING STEPS PER TYPICAL DETAILS. THE MAXIMUM SLOPE OF COMPACTED SUBGRADE BELOW INSULATED FOOTINGS IS 1/2" IN 12"; TOP OF FOOTINGS SHALL BE MAX 1/4" IN 12".
3. ALL PAVEMENT, EXISTING FOUNDATIONS AND UNCONTROLLED GRANULAR FILL SHOULD BE REMOVED FROM THE AREA OF THE PLANNED CONSTRUCTION TO AT LEAST 4 FEET BEYOND THE FOOTING LIMIT.
4. COMPACTED STRUCTURAL FILL SHALL BE USED TO BACKFILL TO THE DESIGN FOOTING SUBGRADE AND BENEATH ALL SLABS ON GRADE AND SHALL CONFORM TO THE SPECIFICATION OF THE GEOTECHNICAL REPORT.
5. STRUCTURAL FILL SHALL BE PLACED IN UNIFORM LIFTS NOT EXCEEDING 8 INCHES IN LOOSE THICKNESS AND BE COMPACTED BENEATH SLABS TO 95 PERCENT OF MAXIMUM DRY DENSITY PER ASTM D-1557, MODIFIED PROCTOR TEST. COMPACT ADJACENT TO FOUNDATION WALLS SUPPORTING UNBALANCED FILL (RETAINING WALLS) TO 94-96 PERCENT OF MAXIMUM DRY DENSITY PER ASTM D-1557. HAND OPERATED EQUIPMENT SHALL BE USED FOR COMPACTION WITHIN 8 FEET OF NEW FOUNDATION WALL. DO NOT BACKFILL UNTIL THE FLOOR FRAMING IS INSTALLED OR THE WALLS ARE OTHERWISE ADEQUATELY BRACED AND THE CONCRETE HAS CURED FOR AT LEAST SEVEN DAYS.
6. PROVIDE DRAIN TO DAYLIGHT AROUND THE PERIMETER OF THE STRUCTURE (SPEC BY OTHERS). REFER TO ARCH/SITE DRAWINGS. REFER TO THE ARCHITECTURAL, STRUCTURAL, ELECTRICAL AND MECHANICAL DRAWINGS FOR ANY BONDOUT REQUIREMENTS. SEE TYPICAL CONCRETE DETAILS FOR BONDOUT REINFORCEMENT REQUIREMENTS.
7. SLOPE FOOTING EXCAVATIONS AS REQUIRED FOR STABILITY AND SAFETY PER OSHA REQUIREMENTS. BRACED EXCAVATIONS SHALL BE DESIGNED BY A PROFESSIONAL ENGINEER REGISTERED IN THE STATE OF MAINE.

REINFORCED CONCRETE

1. CONCRETE WORK SHALL CONFORM TO THE LATEST EDITIONS OF THE FOLLOWING:
 - ACI 301 "SPECIFICATIONS FOR STRUCTURAL CONCRETE"
 - ACI 304 "GUIDE FOR MEASURING, MIXING, TRANSPORTING, AND PLACING CONCRETE"
 - ACI 305 "HOT WEATHER CONCRETING"
 - ACI 308 "COLD WEATHER CONCRETING"
 - ACI 310 "BUILDING CODE REQUIREMENTS FOR REINFORCED CONCRETE"
2. CEMENT: ASTM C150, TYPE I. MAXIMUM AGGREGATE SIZE 3/4". CALCIUM CHLORIDE NOT PERMITTED.
3. CONCRETE FOR FOOTINGS, FOUNDATION WALLS, PIERS AND INTERIOR SLABS SHALL HAVE A MINIMUM 28 DAY COMPRESSIVE STRENGTH OF 3000 PSI, UNO. WATER-CEMENT RATIO SHALL NOT EXCEED 0.50. UNO. CONCRETE FOR EXTERIOR SLABS (INCLUDES ATTACHED AND DETACHED GARAGE SLABS), RAMPS, RETAINING WALLS AND STEPS SHALL HAVE A MINIMUM 28 DAY COMPRESSIVE STRENGTH OF 3500 PSI; WATER-CEMENT RATIO SHALL NOT EXCEED 0.45. CONCRETE EXPOSED TO IN SERVICE FREEZE/THAW CYCLES (INCLUDING, BUT NOT LIMITED TO: FOUNDATION WALLS, FOOTINGS, EXTERIOR SLABS) SHALL BE AIR ENTRAINED WITH AN AIR CONTENT OF 5% TO 6%. EXTERIOR SLABS REQUIRE APPLICATION OF A CURING COMPOUND OR USE CURING TARPS. GENERAL CONTRACTOR COORDINATE USE OF EITHER WITH ARCHITECTURAL REQUIREMENTS FOR SLAB - APPEARANCE, SUITABILITY FOR INSTALLATION OF FUTURES FINISHES, ETC.
4. SLUMP SHALL NOT EXCEED 5" +/- 1" PER ASTM C143 UNLESS AN APPROVED WATER REDUCING ADMIXTURE IS USED. MAXIMUM SLUMP AFTER ADDITION OF ADMIXTURE IS 8".
5. SEE ARCHITECTURAL DRAWINGS FOR FOUNDATION DRAINAGE, UNDERSLAB UTILITIES, UNDERSLAB VAPOR BARRIER AND INSULATION ASSOCIATED WITH CONCRETE WORK. ALSO SEE ARCHITECTURAL DRAWINGS FOR CONCRETE FINISHES AND DEPRESSIONS.
6. CONCRETE SHALL NOT BE PLACED IN WATER OR ON FROZEN GROUND. GENERAL CONTRACTOR SHALL HEAT CONCRETE MATERIALS AND PROTECT CONCRETE AFTER PLACEMENT WHEN PLACING AT OR BELOW 50F TEMPERATURES IN ACCORDANCE WITH ACI308.
7. DEPOSIT CONCRETE IN FORMS IN HORIZONTAL LAYERS NOT DEEPER THAN 18" AND IN A MANNER TO AVOID INCLINED CONSTRUCTION JOINTS. WHERE PLACEMENT CONSISTS OF SEVERAL LAYERS, PLACE EACH LAYER WHILE THE PRECEDING LAYER IS STILL PLASTIC TO AVOID CONSTRUCTION JOINTS.
8. REINFORCING BARS SHALL CONFORM TO ASTM A615 WITH 60,000 PSI YIELD STRENGTH WITH MINIMUM ANCHORAGE AND SPLICE REQUIREMENTS FOR REINFORCING IN ACCORDANCE WITH THE LATEST EDITION OF ACI 318. WELDED WIRE FABRIC SHALL BE 6x6 W4x1.4 AND SHALL CONFORM TO ASTM A-185. PROVIDE IN FLAT SHEETS.
9. MINIMUM CONCRETE PROTECTIVE COVERING FOR REINFORCEMENT, UNLESS NOTED OTHERWISE, SHALL BE AS FOLLOWS:
 - FOOTINGS: 3"
 - FOUNDATION WALLS: 2"
 - EXTERIOR SLABS: 2"
 - INTERIOR SLABS: 1"
 - PIERS: 1.5" TO TIES
10. REINFORCEMENT SHALL BE CONTINUOUS AROUND CORNERS AND AT INTERSECTIONS. PROVIDE LAPPED BARS AT NECESSARY SPLICES OR HOOKED BARS AT DISCONTINUOUS ENDS. PROVIDE CLASS - B TENSION LAP SPLICES FOR ALL REINFORCING UNLESS OTHERWISE SHOWN ON PLAN.
11. WELDING OF REINFORCEMENT IS NOT PERMITTED.
12. PROVIDE ADDITIONAL REINFORCEMENT AROUND CONCRETE OPENINGS AS SHOWN ON THE TYPICAL DETAILS.
13. PROVIDE MIN 6 MIL VAPOR BARRIER UNDER INTERIOR SLABS CAST ON GRADE, OR AS SHOWN ON THE ARCHITECTURAL PLANS.
14. CONCRETE WALLS SHALL BE CAST IN ALTERNATE PANELS NOT EXCEEDING 50 FEET LONG. CONSTRUCTION JOINTS MAY BE USED - SEE TYPICAL DETAILS. SLAB CONTROL JOINTS ARE REQUIRED AS SHOWN.
15. ANCHOR BOLTS SHALL BE HOT DIPPED GALVANIZED J BOLT (SIZED PER DETAILS) SPACED 3'-0" O.C. AND WITHIN 12" OF STEP OR CORNER (UNLESS OTHERWISE NOTED). MINIMUM TWO ANCHOR BOLTS PER ANY WALL SECTION. ANCHOR BOLTS AT SHEARWALL HOLD-DOWNS MUST BE GALVANIZED A307 THREADED ROD WITH DOUBLE NUT AT EMBEDDED END (UNO).
16. USE NON-SHRINK GROUT BENEATH BASE PLATES & BEARING PLATES.
17. TIE HOLES, BUG HOLES, VOIDS AND SURFACE IRREGULARITIES LARGER THAN 1/2" IN DIAMETER OR DEEPER THAN 1/8", OR BOTH, SHOULD BE EITHER PRE-TREATED WITH ENGINEER-APPROVED LIQUID FOUNDATION WATERPROOFING OR REPAIRED WITH A LEAN CONCRETE MIX OF GROUT. SEE ASTM D5218; PREPARATION OF CONCRETE SURFACES FOR ADHERED MEMBRANE WATERPROOFING SYSTEMS, FOR FURTHER DETAILS CONCERNING SUBSTRATE PREPARATION.
18. ALL SLABS REQUIRE CONTROL JOINTS AS SHOWN ON THE DRAWINGS. DEPTH OF JOINT SHALL BE 25% OF CONCRETE THICKNESS. CUT ALTERNATING W/F WIRES AT JOINT LOCATION. CUT TOP BARS ONLY AT HAUNCH SLAB CONDITION (OR 50% OF BARS IN SINGLE LAYER INSTALLATION). SAW CUT JOINTS WITH EARLY ENTRY SAW WITHIN ONE TO FOUR HOURS OR WITH A WET SAW AFTER FOUR TO TWELVE HOURS (AS SOON AS CONCRETE CAN BE SAWED WITHOUT AGGREGATE LOOSENING). GC COORDINATE CONTROL JOINT FINISHING REQUIREMENTS WITH ARCHITECT.

STRUCTURAL STEEL NOTES

1. STRUCTURAL STEEL FABRICATION, ERECTION, AND CONNECTION DESIGN SHALL CONFORM TO AISC "SPECIFICATION FOR THE DESIGN FABRICATION, AND ERECTION OF STRUCTURAL STEEL" 9TH EDITION, AND THE "CODE OF STANDARD PRACTICE, LATEST EDITION, DESIGN AND DETAIL ALL CONNECTIONS ACCORDING TO AISC.
2. STRUCTURAL STEEL: ASTM A36 UNO. STRUCTURAL TUBING: ASTM A500 GRADE B46 KSI.
3. WHERE WELDING IS INDICATED, ALL WELDING SHALL CONFORM TO AWS D11-LATEST EDITION. ELECTRODES SHALL BE CONFORM TO AWS A5.1 E70XX.
4. COAT ALL COLUMN AND BASE PLATES BELOW SLAB WITH BITUMINOUS MASTIC.

FRAMING NOTES:

1. ALL EXTERIOR WALL CONSTRUCTION IS 2x6 @16" UNO.
2. ALL INTERIOR BEARING WALL CONSTRUCTION IS 2x6 @16" O.C. UNO.
3. ALL STRUCTURAL MEMBERS MUST BE CONTINUOUS. LOCATE SPLICES OVER BEARING, UNO.
4. G.C. REFER TO ROOF AND FLOOR FRAMING PLANS FOR LOCATIONS OF POSTS AND JACK STUDS. POSTS (2-2X4 AND LARGER) AND JACK STUDS SHALL STACK CONTINUOUSLY TO THE FOUNDATION WALL UNLESS INTERRUPTED BY A BEAM OR JACK STUDS. ALL JACK STUDS AND POST LOCATIONS REQUIRE MATCHING BLOCKING STUDS BELOW FLOOR SHEATHING DOWN TO FOUNDATION WALL OR LVL BEAMS.
5. IF POST IS NOT SPECIFIED, PROVIDE JACK STUDS BELOW ALL BEAMS EQUAL TO OR GREATER THAN THE WIDTH OF THE BEAM ABOVE (EXAMPLE: 3.5" WIDE LVL REQUIRES (3)-2x JACK STUDS BELOW = 4.5" WIDE)
6. STUDS MUST BE CONTINUOUS UNLESS INTERRUPTED BY A BEAM OR HEADER.
7. PROVIDE I-JOIST BLOCKING IN EACH FRAMING BAY OVER INTERIOR BEARING WALLS OR WHEN I-JOIST IS CONTINUOUS OVER AN EXTERIOR WALL. PROVIDE 1.25" WIDE ENGINEERED RIMBOARD AT PERIMETER OF BUILDING, UNO.
8. INSTALL ENGINEERED FRAMING PRODUCTS PER MANUFACTURER'S INSTRUCTIONS.
9. ALL FLOOR, ROOF AND DECK/BALCONY FRAMING MEMBERS REQUIRE SIMPSON HANGERS, UNO. CONNECTION HARDWARE IN CONTACT WITH PRESERVATIVE-TREATED LUMBER AND USED IN AN INTERIOR ENVIRONMENT SHALL BE HOT DIPPED GALVANIZED (SIMPSON Z-MAX), OR STAINLESS STEEL WITH MATCHING FASTENERS.
10. ALL BEAM (COLUMN) CONNECTIONS REQUIRE HARDWARE (UNO). SEE DETAILS FOR SPECIFIC CONNECTIONS. MINIMUM CONNECTIONS: WOOD BEAM TO LALLY POST REQUIRES SIMPSON LCC TYPE CONNECTION, 5.5" WIDE BEAM TO 5.5" WIDE COLUMN REQUIRES (2) SIMPSON AC6 CLIPS (AC4 AT 3.5/3.5').
11. ALL TIMBER FRAMING SHALL BE IN ACCORDANCE WITH THE NATIONAL DESIGN SPECIFICATION FOR WOOD CONSTRUCTION (NDS) 2005 EDITION. UNLESS NOTED OTHERWISE, ALL WOOD FRAMING SHALL BE FASTENED IN ACCORDANCE WITH 2003 IBC, SECTION 2304.4.
12. FRAMING GRADES:
 - LUMBER (2x STUDS, JOISTS, RAFTERS) SHALL BE #2 AND BETTER S.P.F. LESS THAN 19% MOISTURE CONTENT
 - WOOD I-JOISTS: SPECIFIC GRADES SHOWN ON THE DRAWINGS.
 - LAMINATED VENEER LUMBER (LVL) - 2.0 E, 3100 Fb, 285 Fv
 - PRESERVATIVE TREATED 2x FRAMING LUMBER (PT) SHALL BE #2 AND BETTER SOUTHERN YELLOW PINE TREATED IN ACCORDANCE WITH ANPA UG3B "EXTERIOR, ABOVE GROUND." WOOD CLOSER THAN 8', OR IN CONTACT WITH GRADE, SHALL BE TREATED IN ACCORDANCE WITH ANPA UCA4 "GROUND CONTACT, GENERAL USE." ARCHITECTURALLY EXPOSED TIMBER MAY REQUIRE ALTERNATE SPECIES AND/OR TREATMENT - REFERENCE DRAWINGS.
13. MIN SHEATHING (ALSO SEE ARCHS):
 - EXTERIOR WALL: 1/2" EXPOSURE 1. 8d AT 6" O.C. AT PANEL EDGES, 8" O.C. WITHIN PANEL UNO. (ALSO SEE SHEARWALL NOTES FOR ADDITIONAL NAILING). NOTE: NAILS DRIVEN INTO PT FRAMING MEMBERS SHALL BE HAND NAILED AND HOT DIPPED GALV. GALV GUN NAILS ARE NOT AN ACCEPTABLE SUBSTITUTE WITHOUT PRIOR ENGINEER APPROVAL.
 - FLOOR: 23/32" ADVANTECH INSTALLED WITH STRENGTH AXIS PERPENDICULAR TO SUPPORTS. ADHESIVE: 0.25" BEAD OF POLYURETHANE OR SOLVENT-BASED ADHESIVE APPLIED TO CLEAN, DRY FLOOR JOIST. FASTENER: 8d RING SHANK NAIL (10d FOR THICKNESS > 0.75") OR APPROVED SCREW. FASTENER SPACING: 6" O.C. AT EDGES, 12" O.C. WITHIN PANEL
 - ROOF: 5/8" ADVANTECH INSTALLED WITH STRENGTH AXIS PERPENDICULAR TO SUPPORTS. 8d AT 6" O.C. AT PANEL EDGES, 12" O.C. WITHIN PANEL
 - NAIL HEAD MUST BE DRIVEN FLUSH. SHTG WITH OVERDRIVEN NAILS MUST BE REFASTENED.
14. ALL BUILT-UP BEAMS AND COLUMNS SHALL BE NAILED AS FOLLOWS (UNO.):
 - COLUMNS, KING/JACK STUDS: 2-10d NAILS AT 8" O.C.
 - BEAMS LESS THAN 12" DEEP: 2-16d NAILS AT 12" O.C. IN EACH PLY
 - BEAMS DEEPER THAN 12" (INCLUDING 12"): 3-16d NAILS AT 12" O.C. IN EACH PLY
 - (SIDE-LOADED BEAMS MAY REQUIRE ADDITIONAL CONNECTIONS - SEE FRAMING DETAILS)
15. DRILLED EPOXY ANCHORS SHALL BE HOT DIP GALV A307 THREADED ROD WITH SIMPSON 'AT' EPOXY. BLOW HOLES FREE OF DUST AND INSTALL PER MANUFACTURER'S INSTRUCTIONS, TYP UNO. DRILLED EXPANSION ANCHORS SHALL BE MECHANICALLY GALVANIZED SIMPSON 5/8" WEDGE-ALL ANCHOR; RSS SCREWS SHALL BE CLIMATEK COATED AND MANUFACTURED BY GRK FASTENER. RSS SCREWS IN CONTACT WITH PRESERVATIVE-TREATED LUMBER SHALL BE STAINLESS STEEL.
16. CONSULT ENGINEER PRIOR TO SHIMMING ANY STRUCTURAL MEMBER. CEDAR SHIMS ARE NOT ACCEPTABLE.
17. SHEARWALL TOP AND BOTTOM PLATES MUST BE CONTINUOUS - DO NOT NOTCH OR CUT.

SUBMITTALS

- CONTRACTOR SHALL SUBMIT COMPLETE SHOP DRAWINGS, INCLUDING:
- ROOF TRUSS CALCULATIONS STAMPED BY AN ENGINEER LICENSED IN MAINE
 - ROOF TRUSS ERECTION DRAWINGS

TESTING

OWNER SHALL ENGAGE A QUALIFIED TESTING AGENCY TO CONDUCT PERIODIC TESTS TO CONFIRM CONSTRUCTION IS IN ACCORDANCE WITH THE DRAWINGS AND SPECIFICATIONS. TEST REPORTS SHALL BE SUBMITTED TO THE ARCHITECT AND ENGINEER, INCLUDING:

- CONCRETE SLUMP, TEMPERATURE AND AIR CONTENT AT POINT OF PLACEMENT
- CONCRETE COMPRESSION TESTS

DESIGN LOADS

1. BUILDING CODE:
 - INTERNATIONAL BUILDING CODE (2003)
 - ASCE 7-05 MINIMUM DESIGN LOADS FOR BUILDINGS
2. FLOOR LIVE LOADS
 - STAIRS AND CORRIDORS = 100 PSF
 - LIVING SPACE = 40 PSF
3. ROOF SNOW LOADS:
 - GROUND SNOW LOAD (Ps): 50 PSF
 - EXPOSURE FACTOR (Ce): 1.0
 - THERMAL FACTOR (Cl) = 1.1
 - IMPORTANCE FACTOR (I): 1.0
4. DESIGN WIND LOADS:
 - BASIC WIND SPEED: 100 MPH
 - EXPOSURE: C
 - IMPORTANCE FACTOR: 1.0

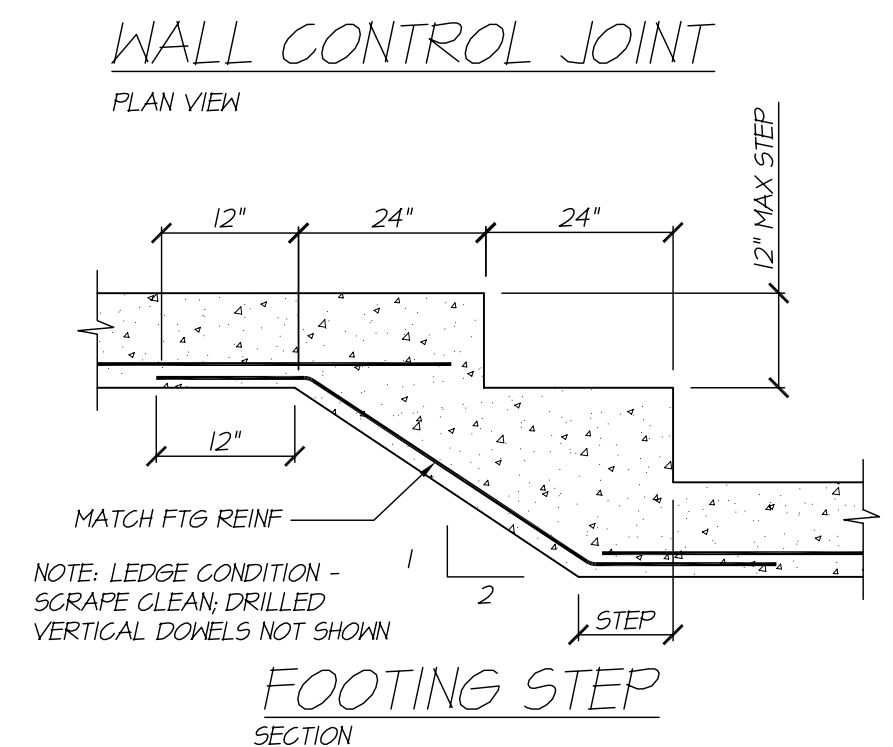
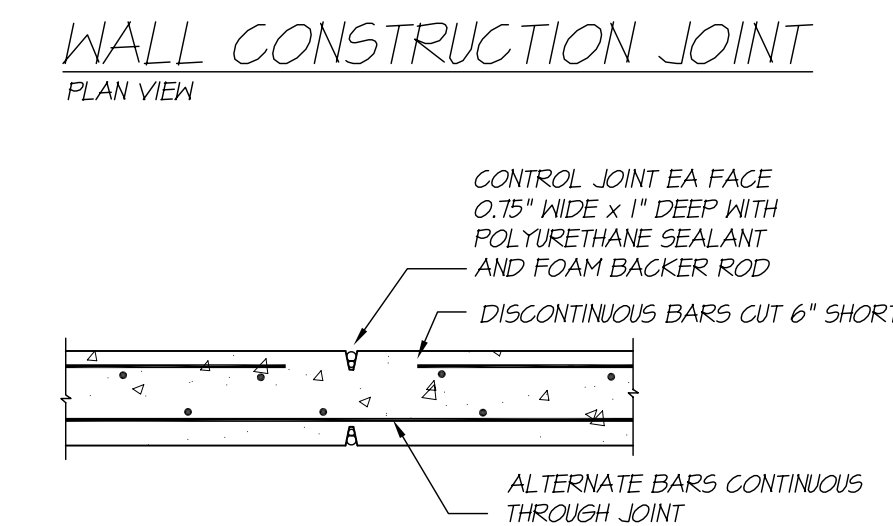
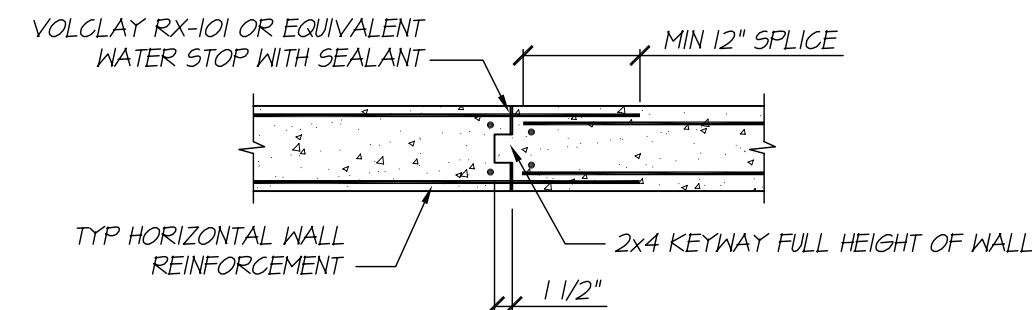
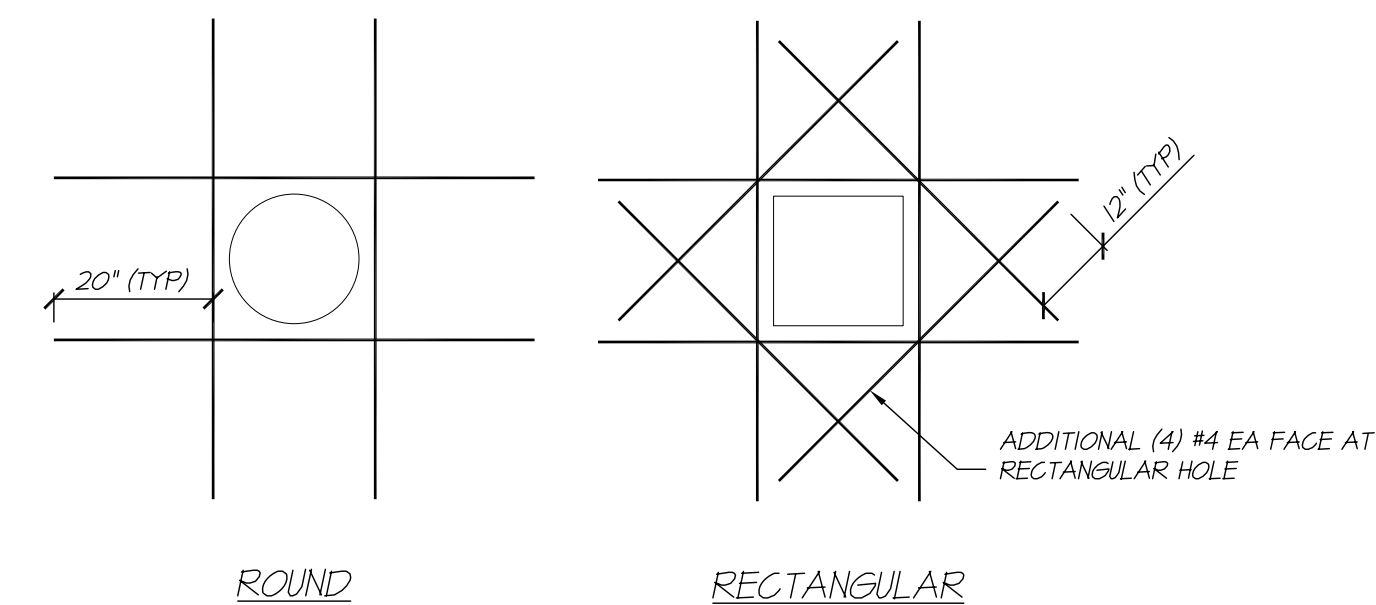
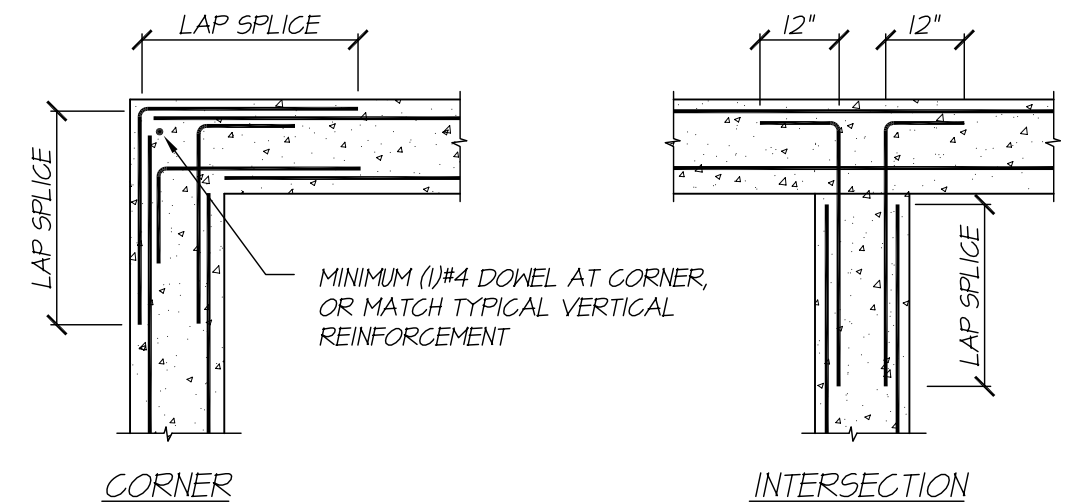
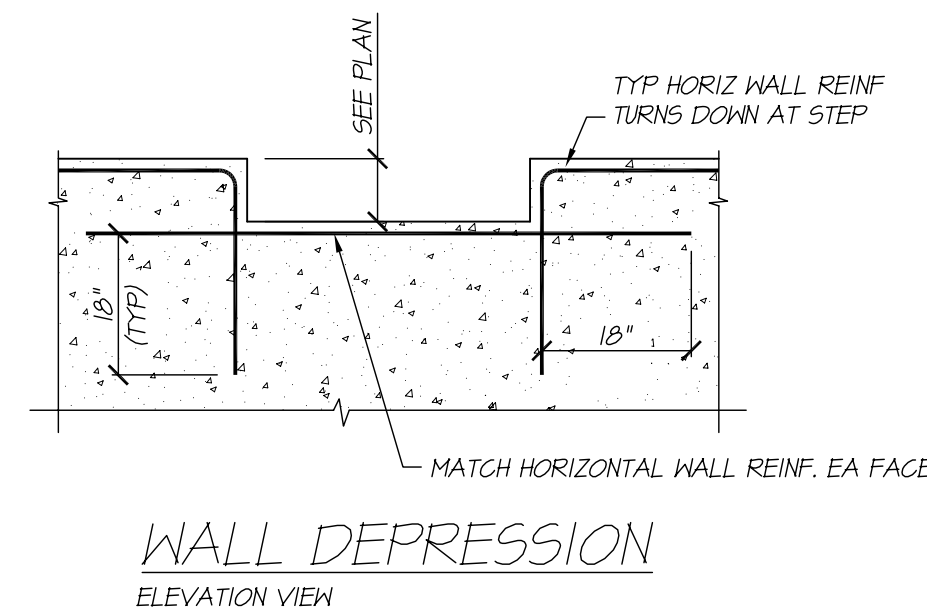

HAMMOND APARTMENTS - BUILDING 'B'
56 HAMMOND STREET
PORTLAND, MAINE

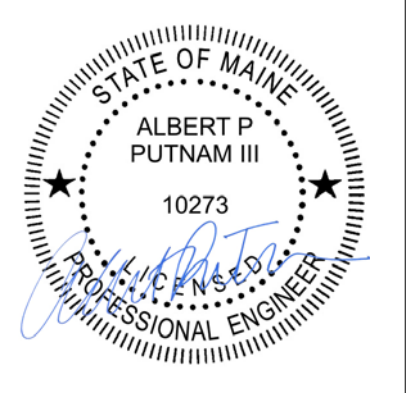

ALBERT PUTNAM PE
STRUCTURAL ENGINEER
183 PARK ROW
BRUNSWICK, ME 04011
(207) 729-6230
www.albertputnam.com

05.21.2012 PERMIT

GENERAL NOTES
TYPICAL DETAILS

S100B

ISSUED FOR PERMIT

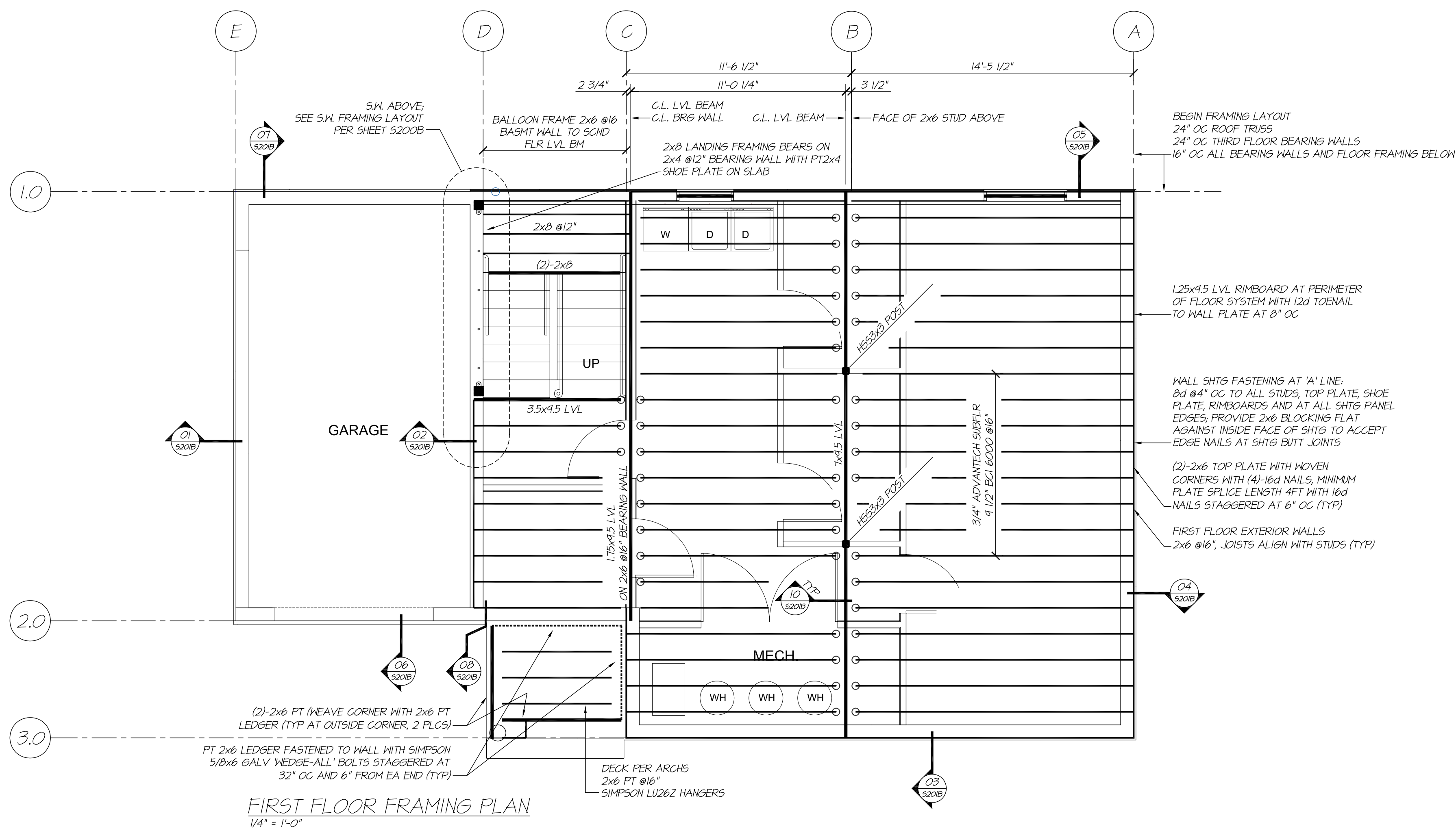

FIRST FLOOR FRAMING PLAN
1/4" = 1'-0"

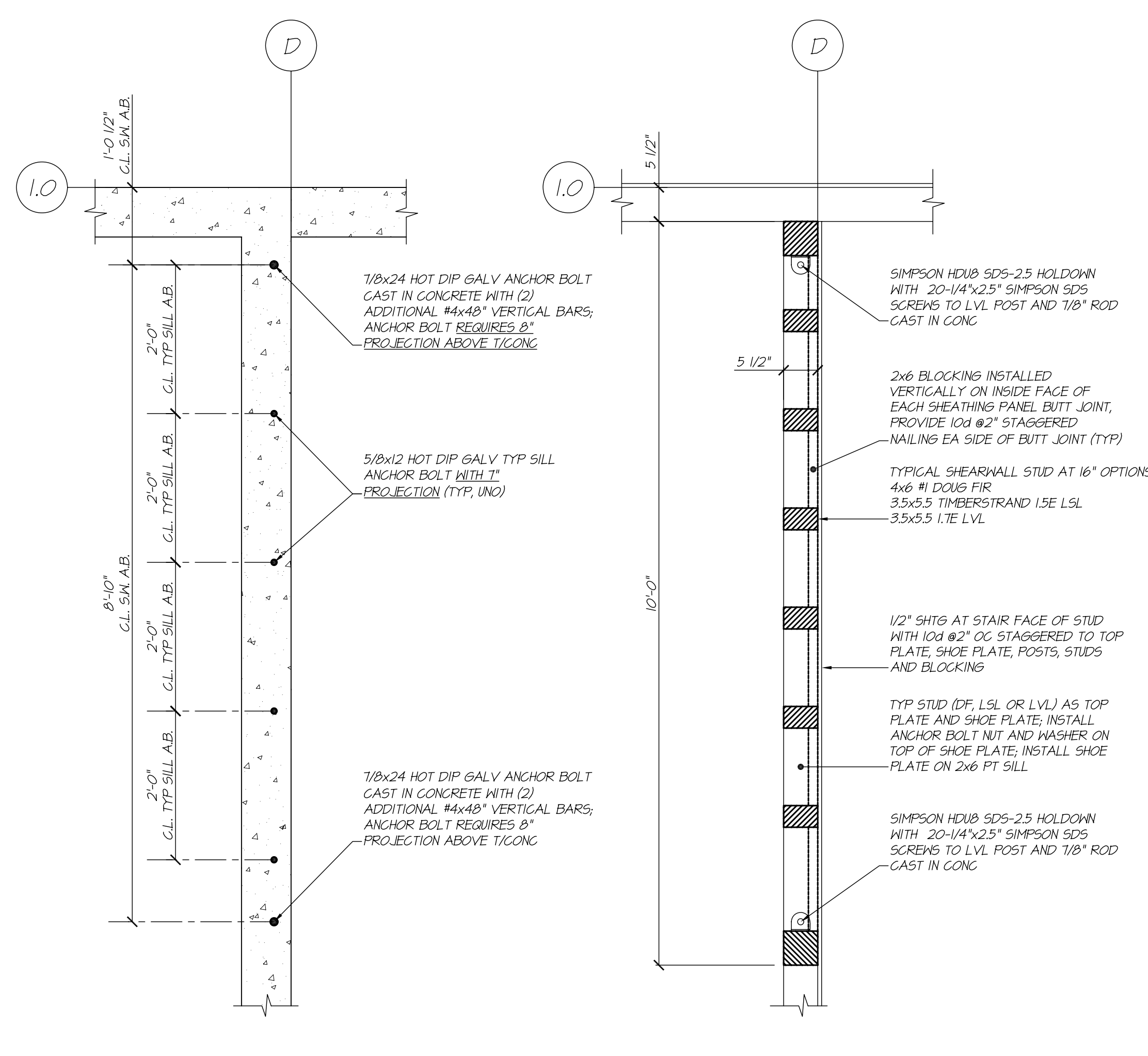

S.W. ANCHOR BOLT LAYOUT
3/4" = 1'-0"

S.W. FRAMING LAYOUT
3/4" = 1'-0"

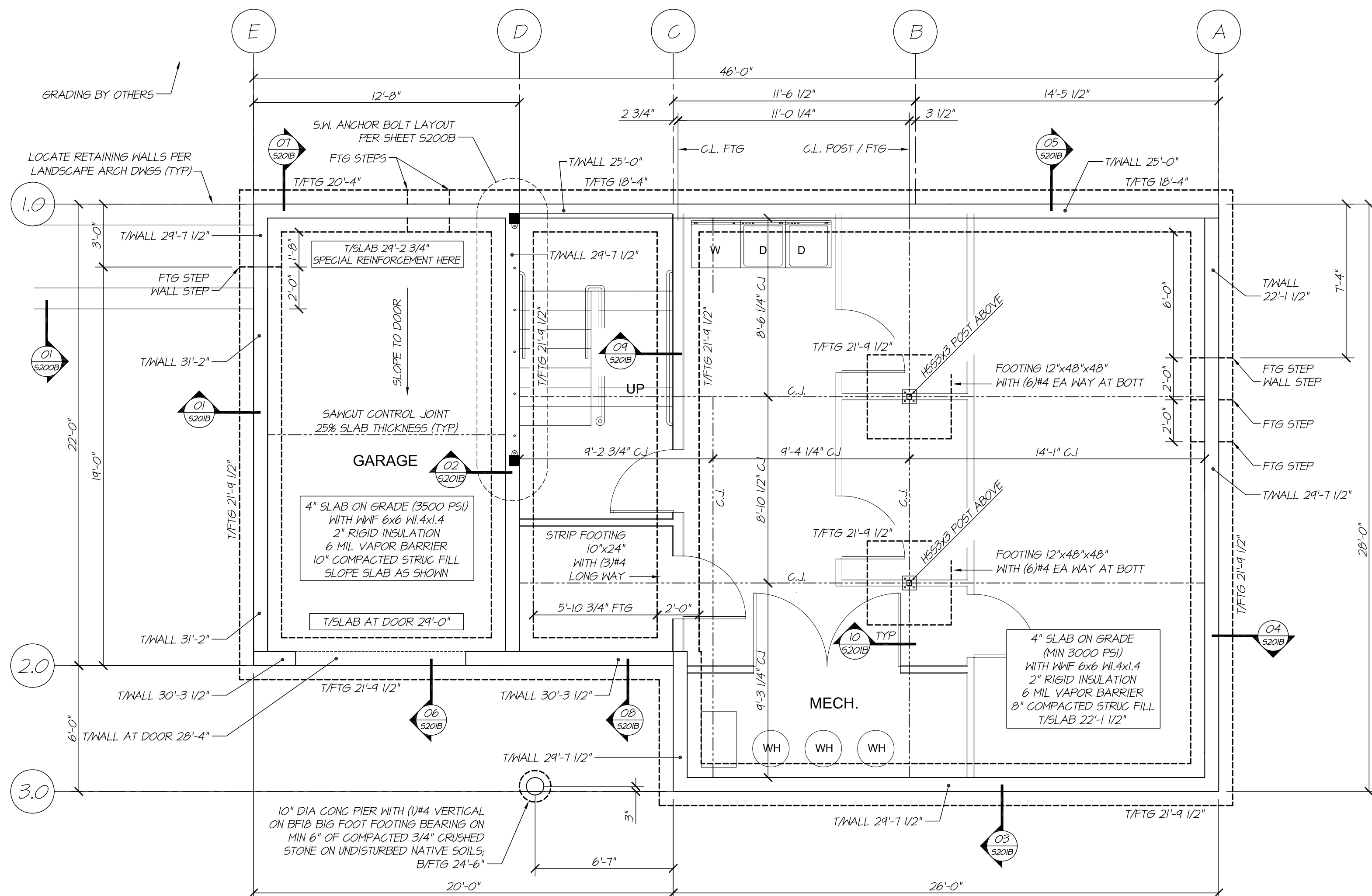

FOUNDATION PLAN
1/4" = 1'-0"

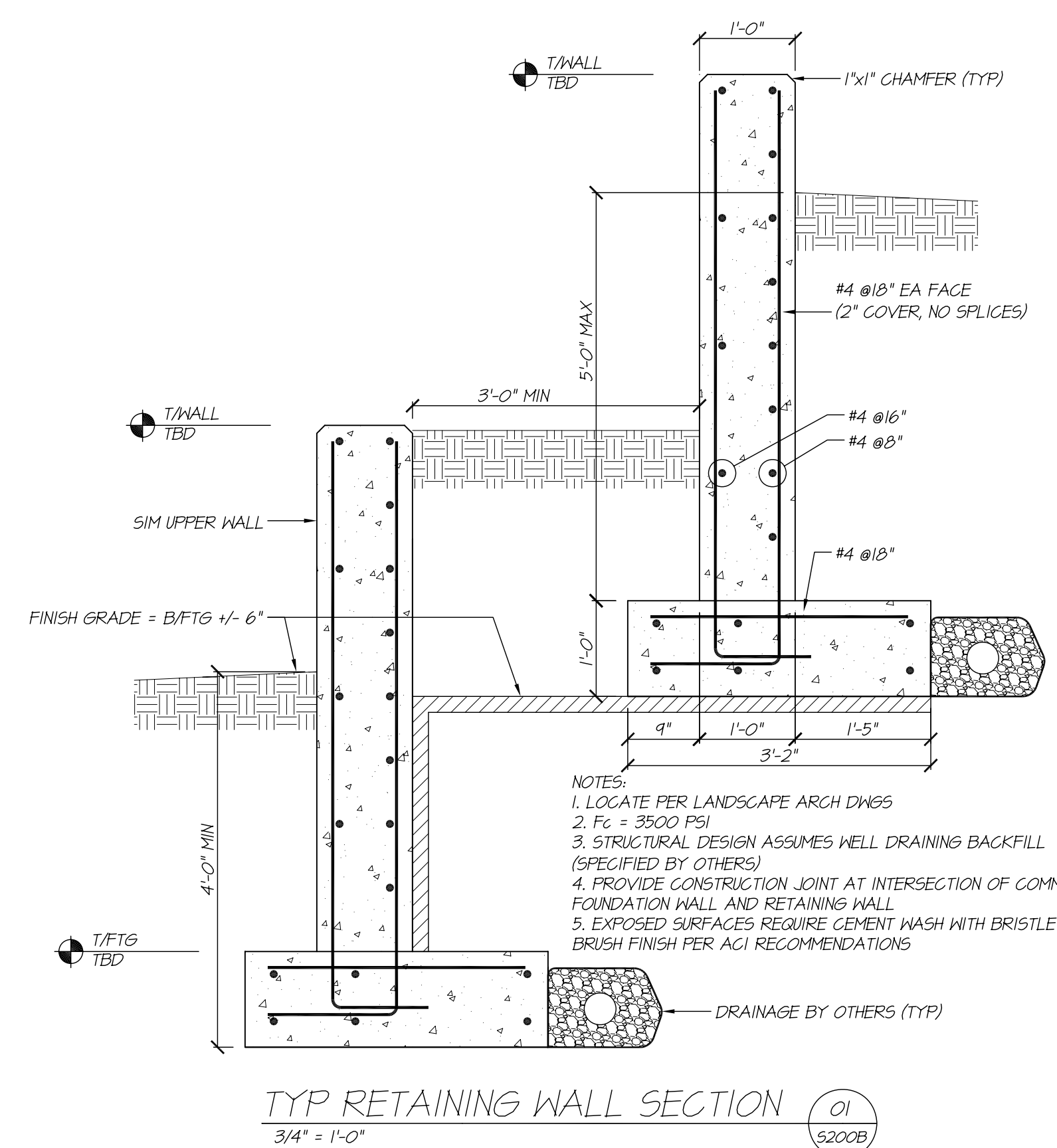

TYP RETAINING WALL SECTION
3/4" = 1'-0"

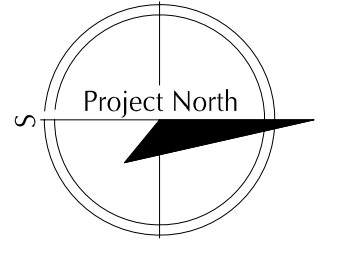

HAMMOND APARTMENTS - BUILDING 'B'
56 HAMMOND STREET
PORTLAND, MAINE

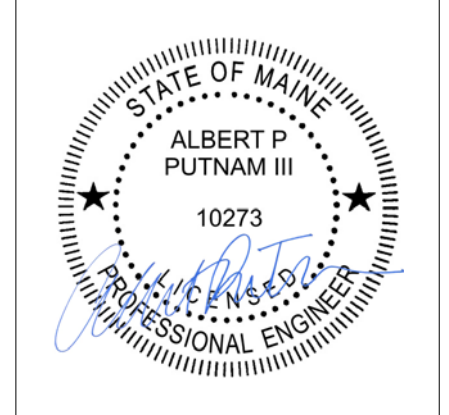

ALBERT PUTNAM PE
STRUCTURAL ENGINEER
183 PARK ROW
BRUNSWICK, ME 04011
(207) 729-6230
www.albertputnam.com

05.21.2012 PERMIT

FOUNDATION PLAN
FIRST FLOOR FRAMING PLAN

S200B

ISSUED FOR PERMIT

OWNERSHIP AND USE OF DOCUMENTS:
DRAWINGS AND SPECIFICATIONS ARE INSTRUMENTS OF PROFESSIONAL SERVICE AND SHALL REMAIN THE PROPERTY OF THE ENGINEER. THESE DOCUMENTS ARE NOT TO BE REPRODUCED OR TRANSMITTED IN ANY FORM OR BY ANY MEANS, ELECTRONIC OR MECHANICAL, INCLUDING PHOTOCOPYING, RECORDING, OR BY ANY INFORMATION STORAGE AND RETRIEVAL SYSTEM, WITHOUT THE WRITTEN AUTHORIZATION OF ALBERT PUTNAM PE.

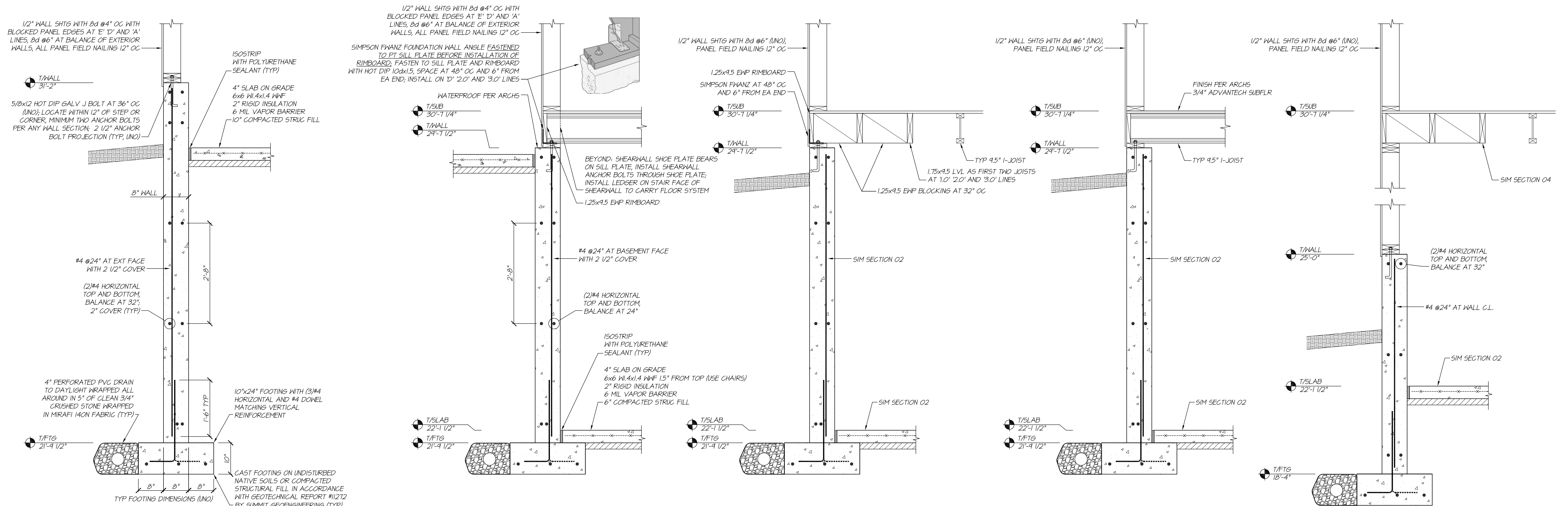
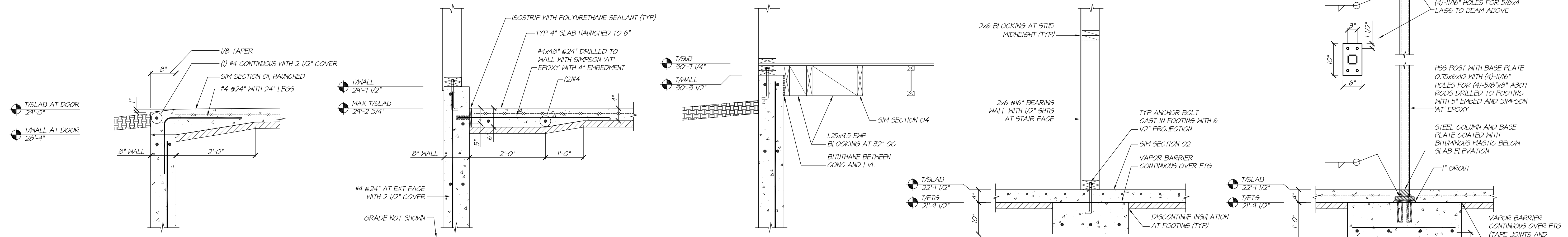

HAMMOND APARTMENTS - BUILDING 'B'

56 HAMMOND STREET
PORTLAND, MAINE

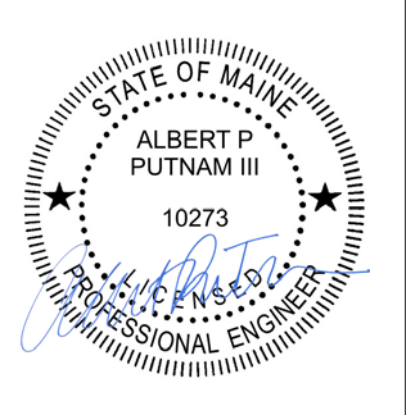

ALBERT PUTNAM PE
STRUCTURAL ENGINEER
183 PARK ROW
BRUNSWICK, ME 04011
(207) 729-6230
www.albertputnam.com

05.21.2012 PERMIT

FRAMING DETAILS
FOUNDATION DETAILS

S201B

ISSUED FOR PERMIT

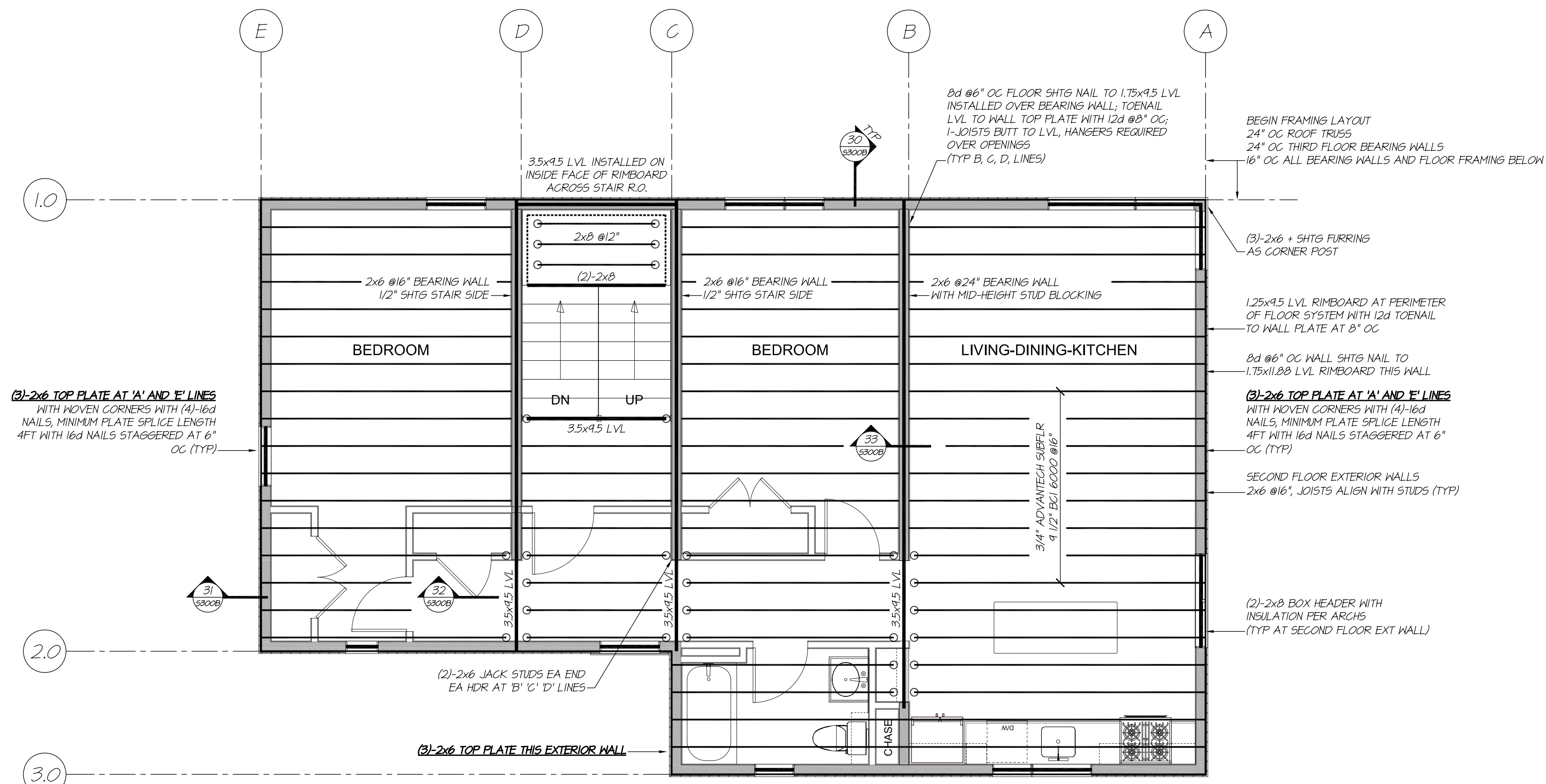
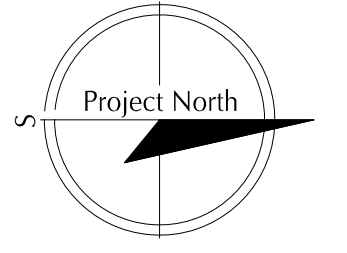

THIRD FLOOR FRAMING PLAN
1/4" = 1'-0"

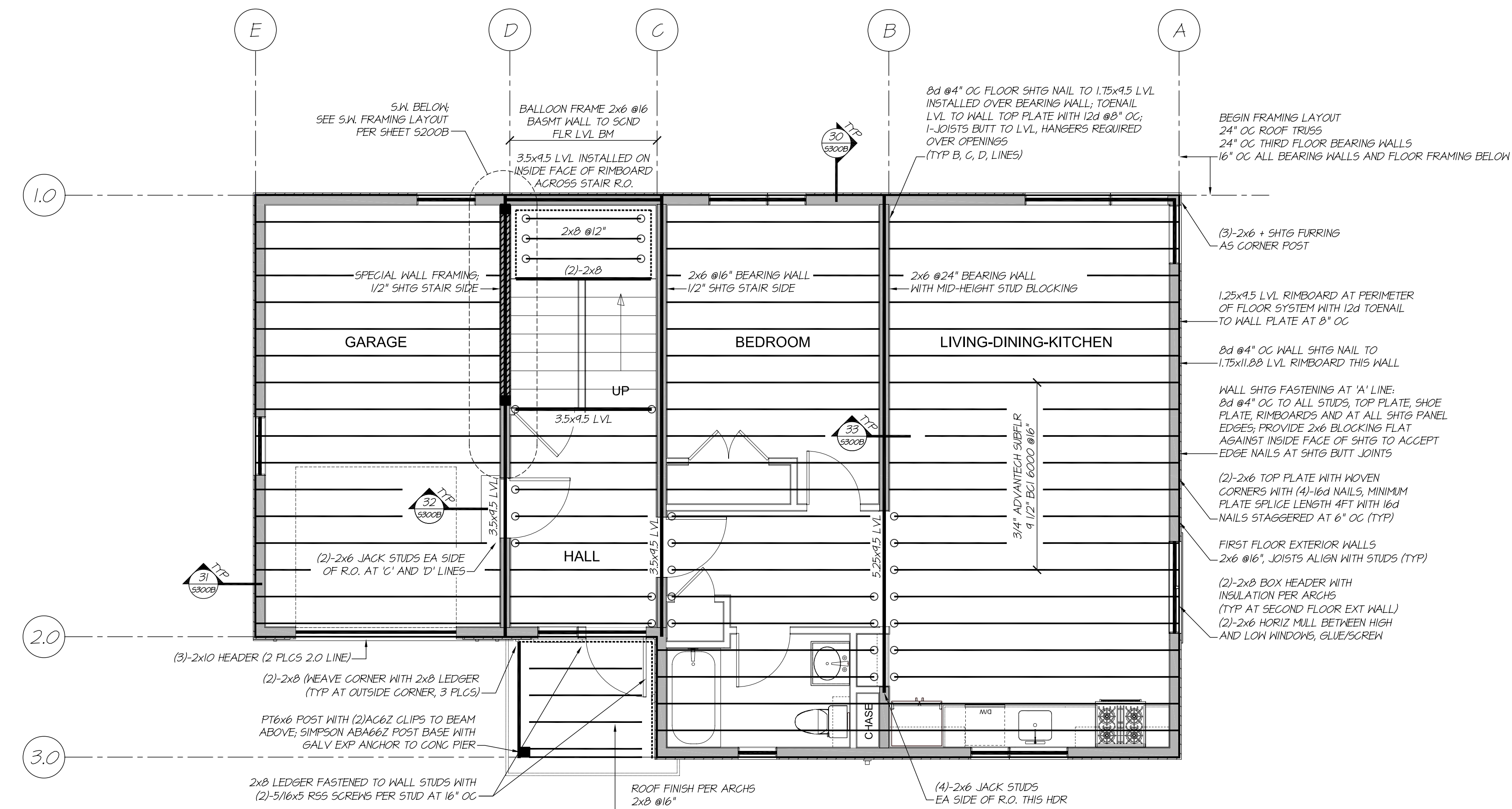

SECOND FLOOR FRAMING PLAN
1/4" = 1'-0"

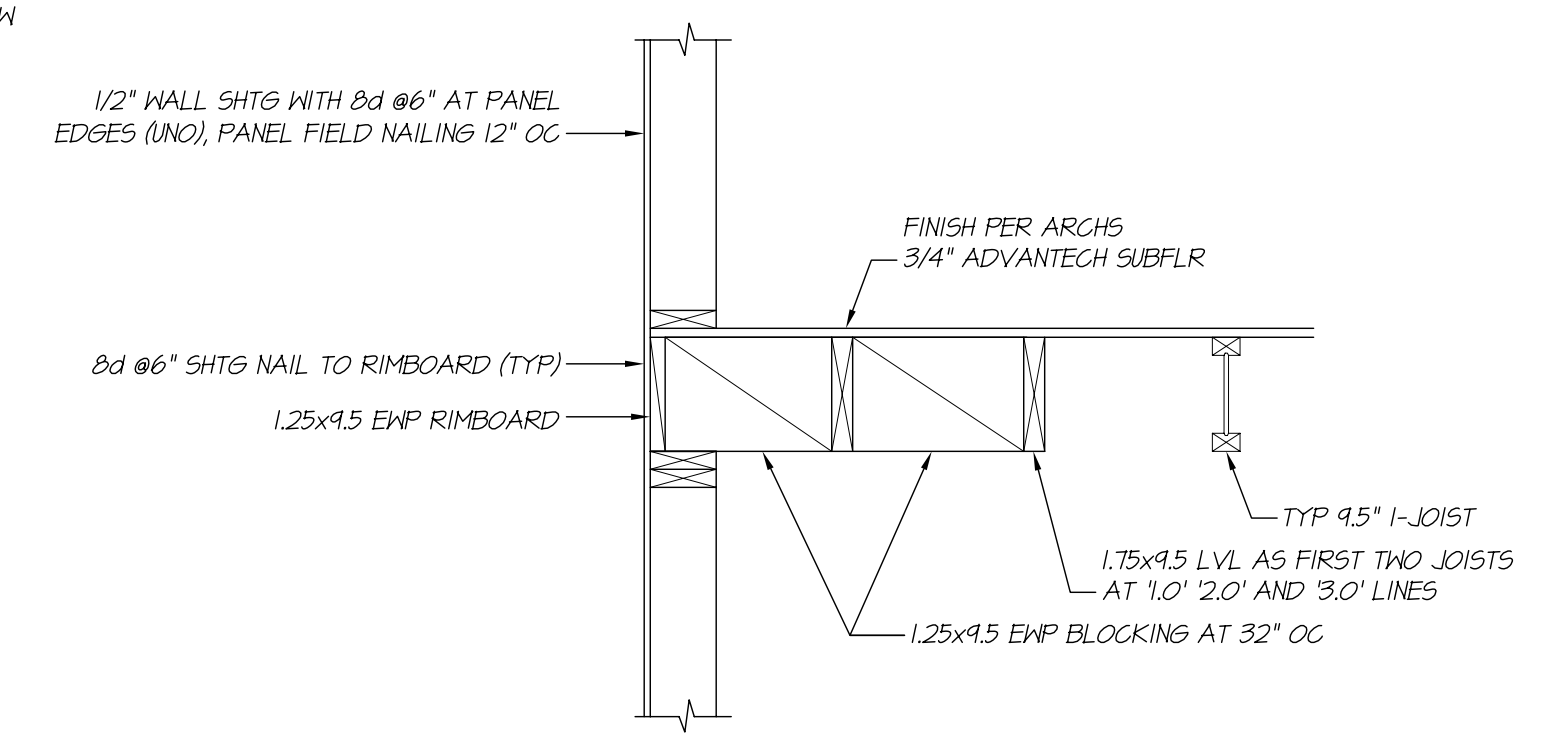

SECTION 30
3/4" = 1'-0"

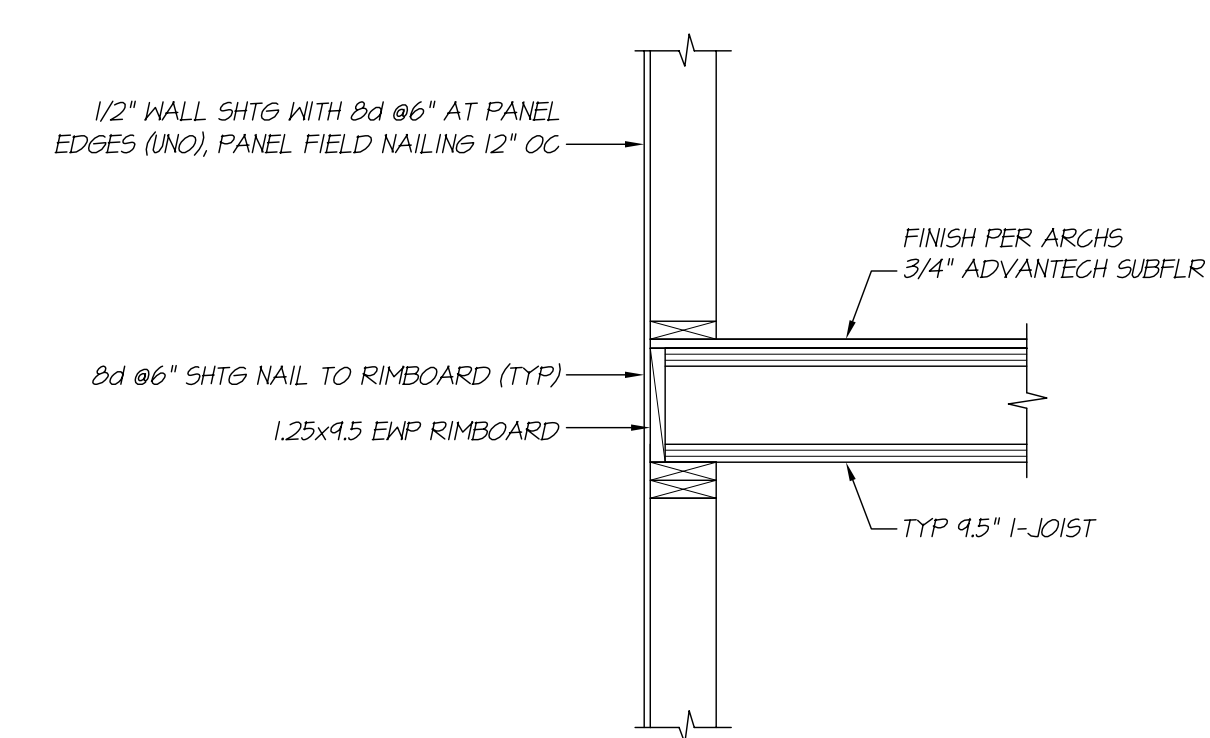

SECTION 31
3/4" = 1'-0"

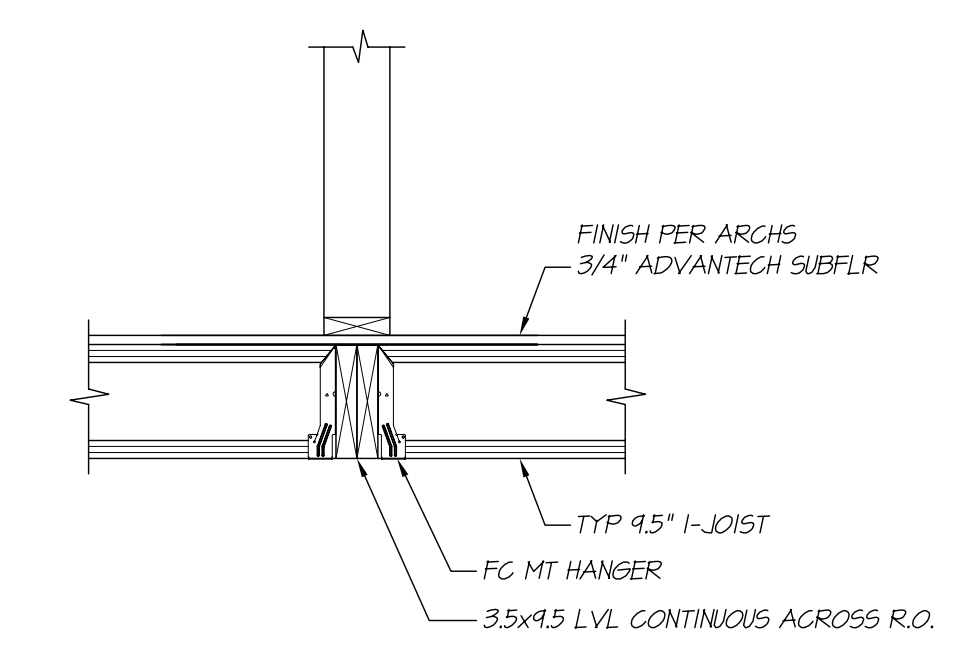

SECTION 32
3/4" = 1'-0"

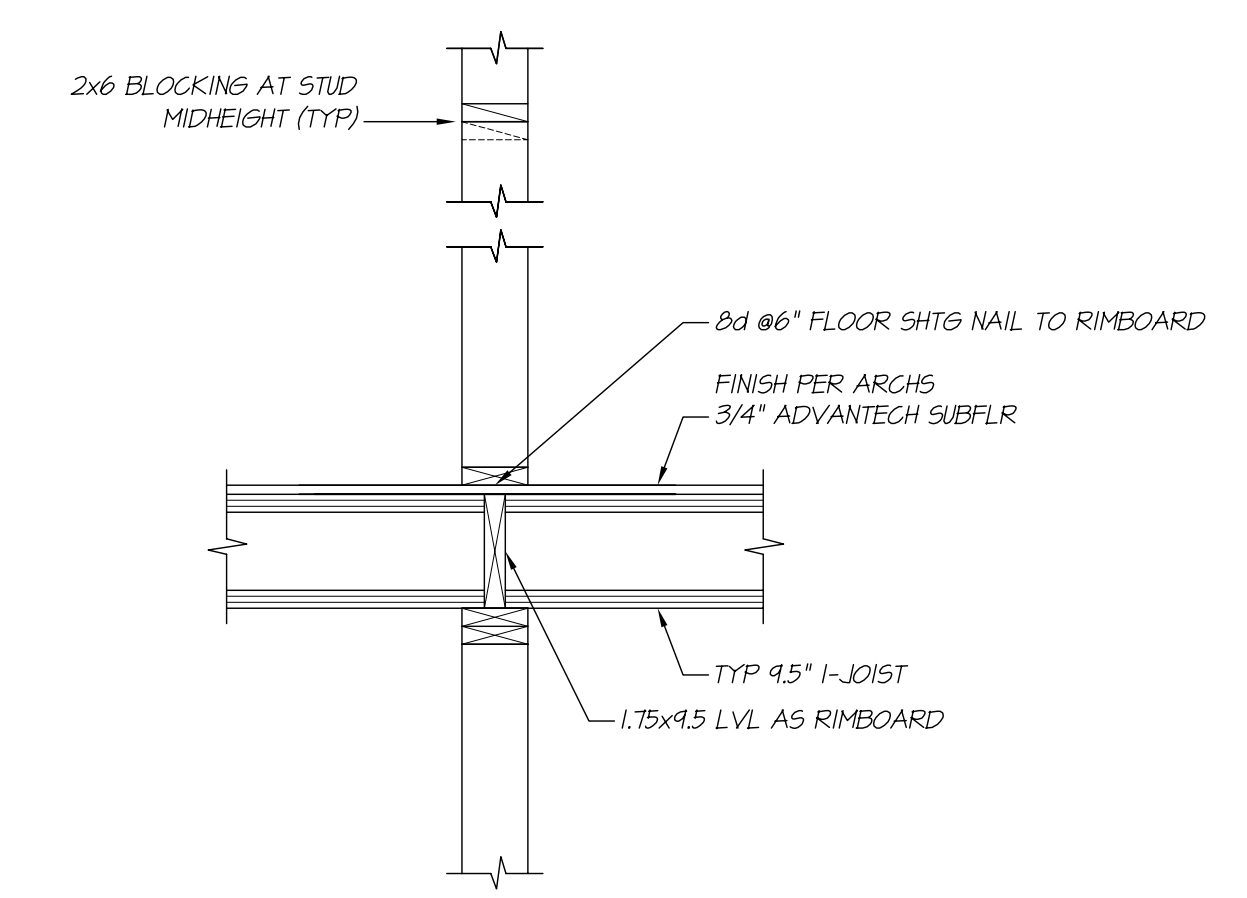

SECTION 33
3/4" = 1'-0"

HAMMOND APARTMENTS - BUILDING 'B'
56 HAMMOND STREET
PORTLAND, MAINE

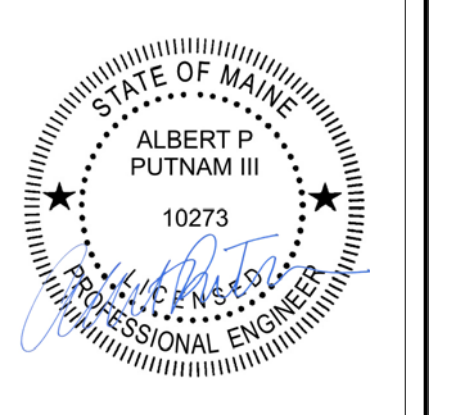

ALBERT PUTNAM PE
STRUCTURAL ENGINEER
183 PARK ROW
BRUNSWICK, ME 04011
(207) 729-6230
www.albertputnam.com

05.21.2012 PERMIT

THIRD FLOOR FRAMING
SECOND FLOOR FRAMING

S300B

ISSUED FOR PERMIT

OWNERSHIP AND USE OF DOCUMENTS:
DRAWINGS AND SPECIFICATIONS ARE INSTRUMENTS OF PROFESSIONAL SERVICE AND SHALL REMAIN THE PROPERTY OF THE ENGINEER. THESE DOCUMENTS ARE NOT TO BE REPRODUCED OR COPIED IN ANY MANNER WITHOUT THE WRITTEN AUTHORIZATION OF ALBERT PUTNAM PE.

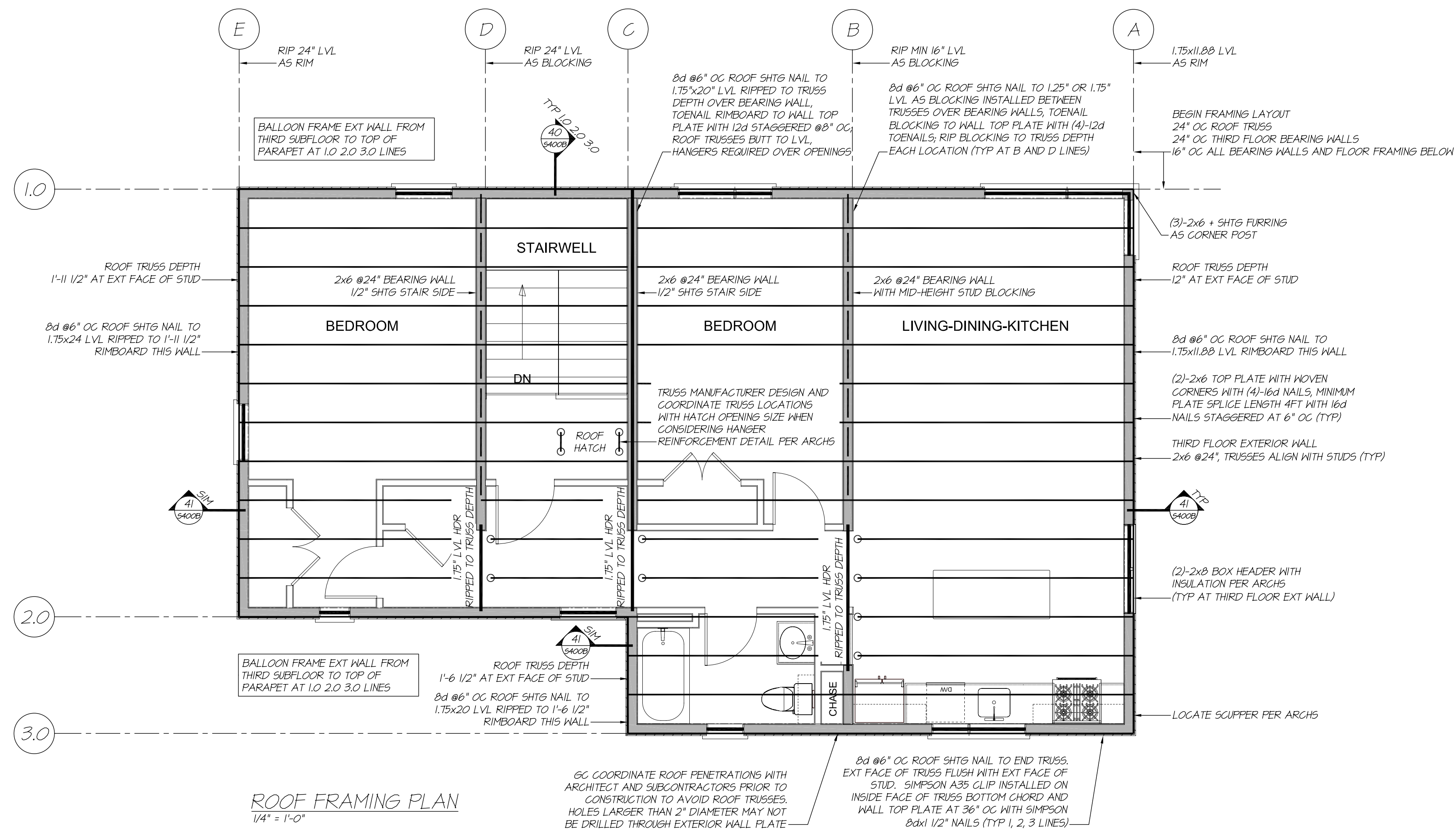

ROOF FRAMING PLAN
1/4" = 1'-0"

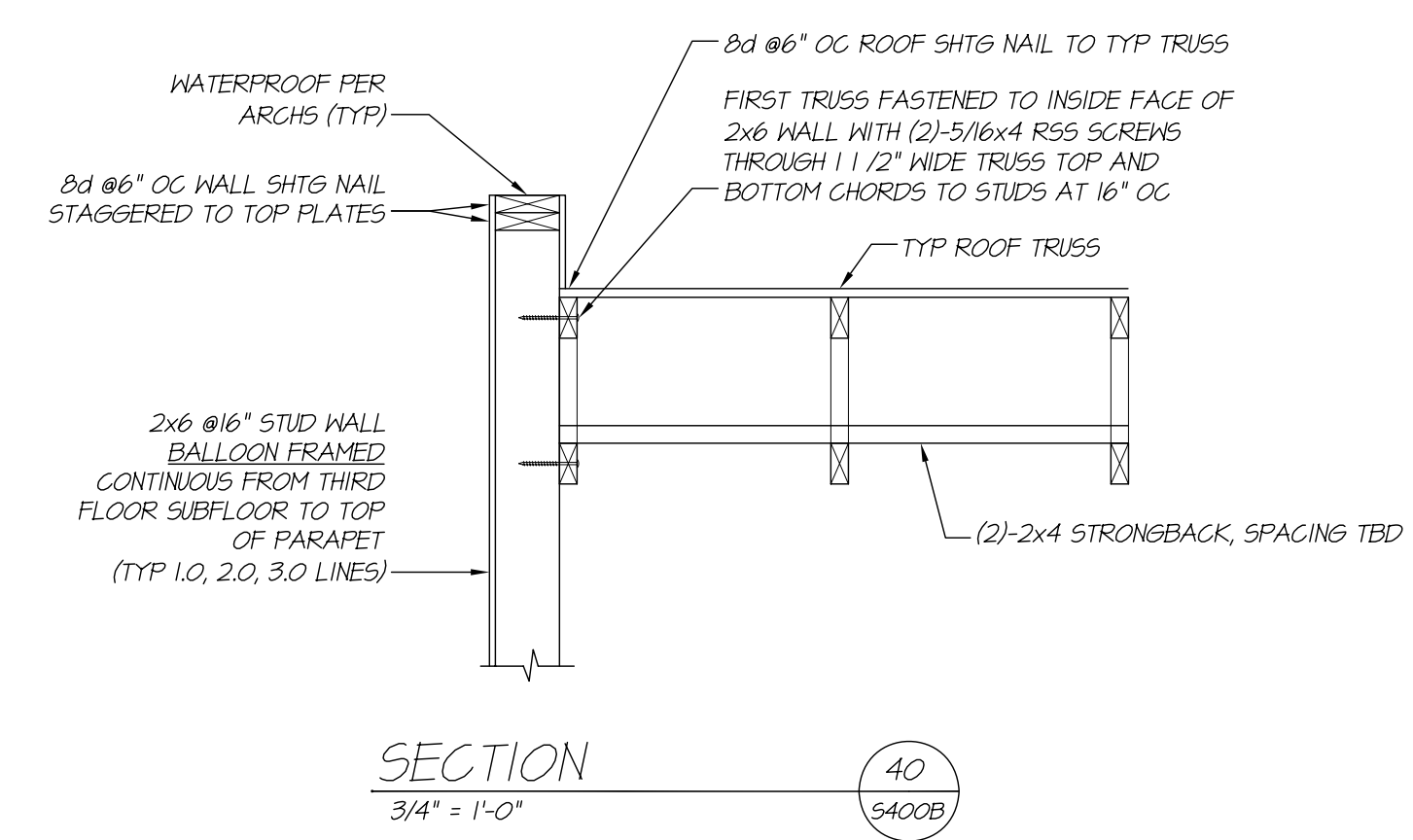

SECTION
3/4" = 1'-0" 40
S400B

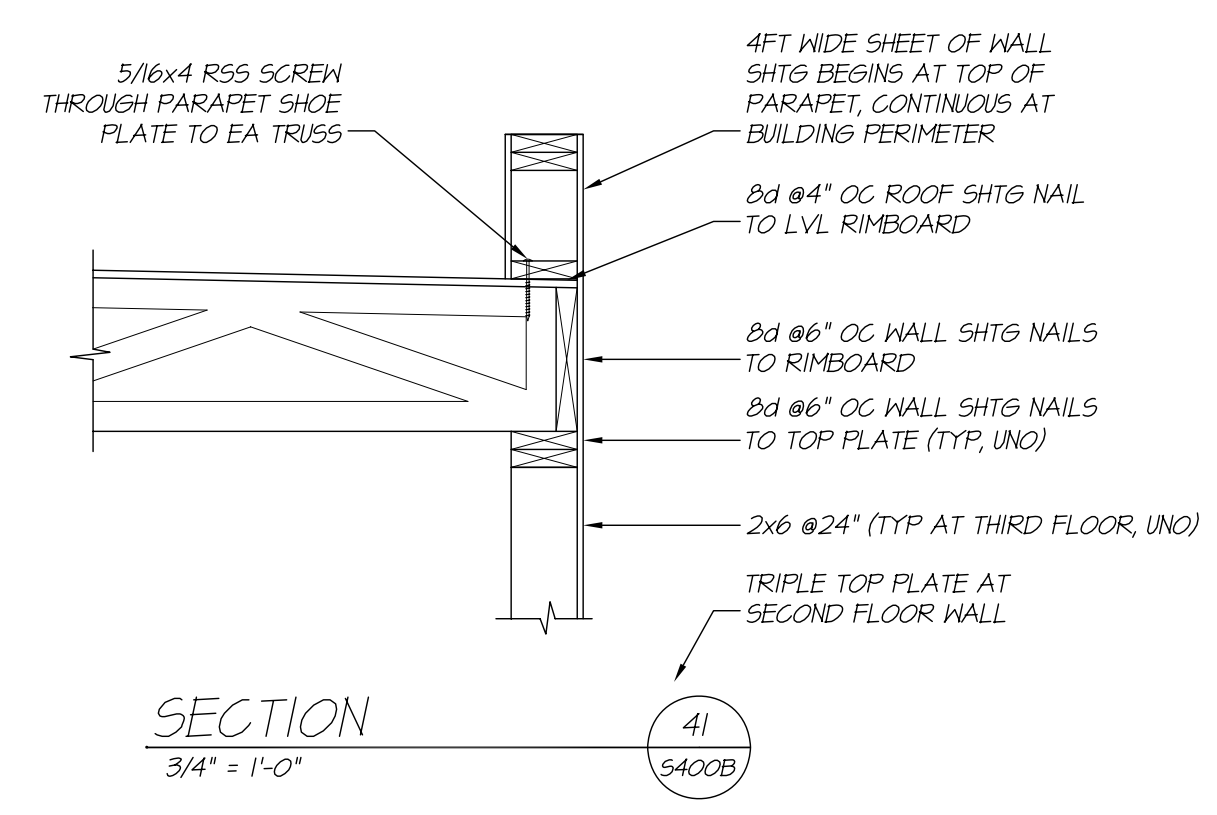

SECTION
3/4" = 1'-0" 41
S400B

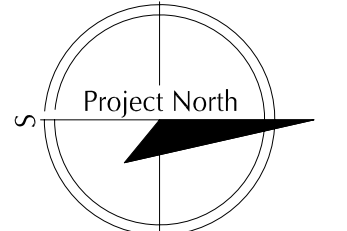

HAMMOND APARTMENTS - BUILDING 'B'

56 HAMMOND STREET
PORTLAND, MAINE

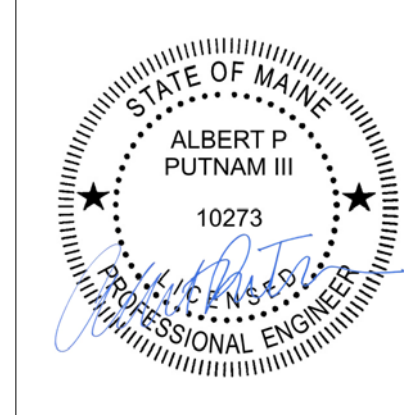

ALBERT PUTNAM PE
STRUCTURAL ENGINEER
183 PARK ROW
BRUNSWICK, ME 04011
(207) 729-6230
www.albertputnam.com

05.21.2012 PERMIT

ROOF FRAMING

S400B

ISSUED FOR PERMIT

OWNERSHIP AND USE OF DOCUMENTS:
DRAWINGS AND SPECIFICATIONS AS INSTRUMENTS OF PROFESSIONAL SERVICE ARE AND SHALL REMAIN THE PROPERTY OF THE ENGINEER. THESE DOCUMENTS ARE NOT TO BE USED IN WHOLE OR IN PART FOR ANY OTHER PROJECT OR PURPOSES, IN OR OUT OF STATE, WITHOUT THE WRITTEN AUTHORIZATION OF ALBERT PUTNAM PE.