

5 LANDING DETAIL WITH GUARDRAIL
1" = 1'-0"

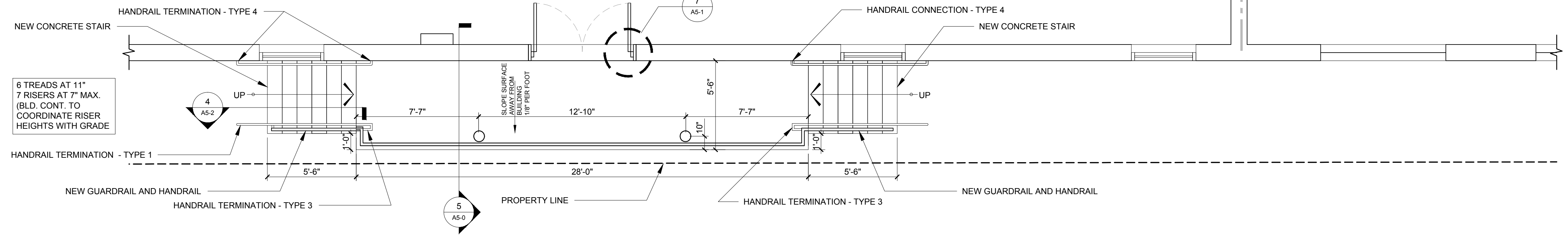

3 STAIR / RAMP DETAIL
1/4" = 1'-0"

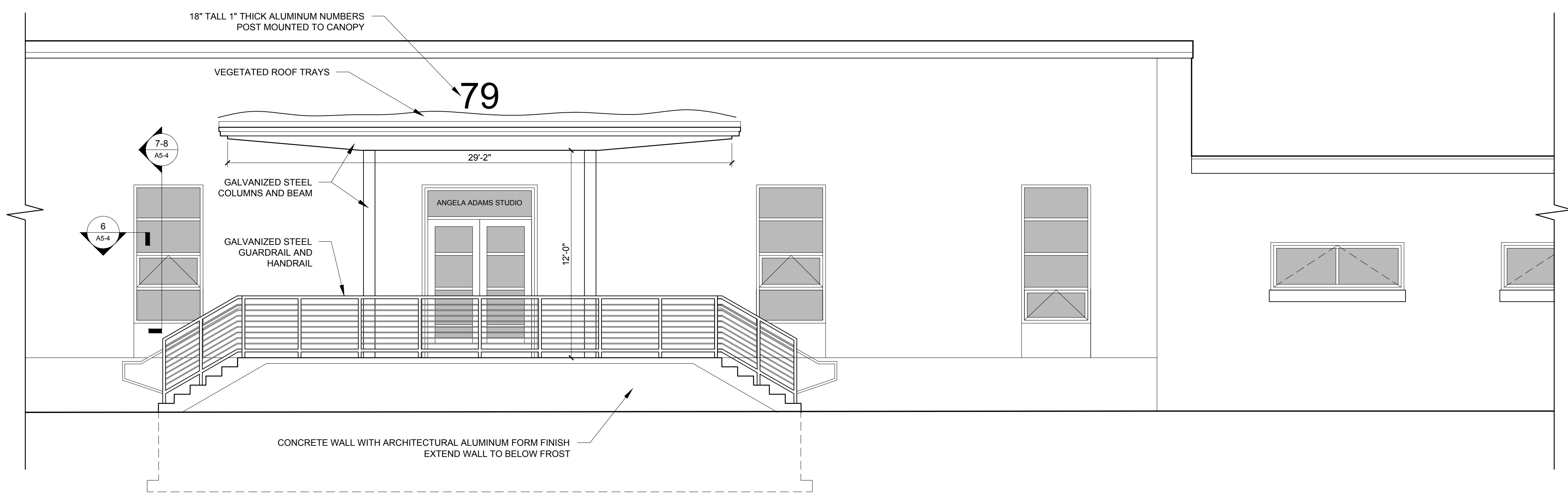

4 STAIR / RAMP ELEVATION
1/4" = 1'-0"

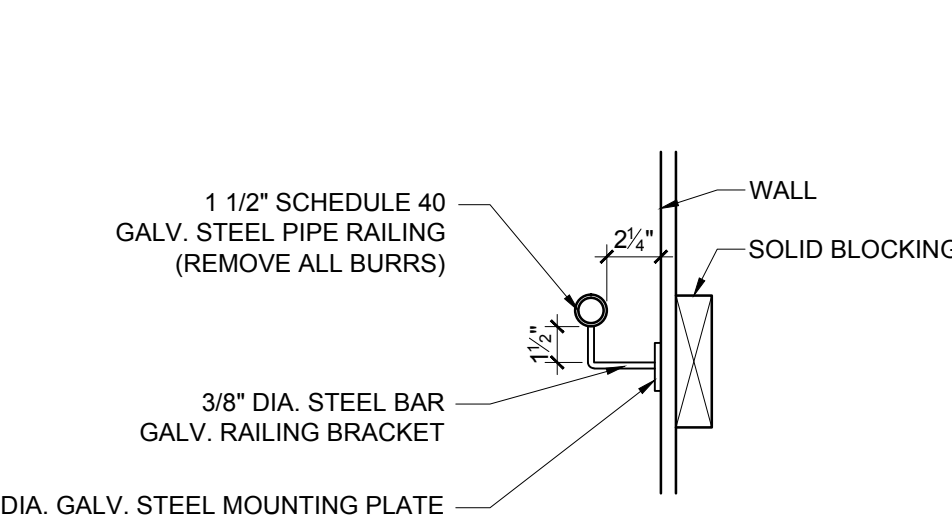

2 TYPICAL RAILING CONNECTION INTO WALL
1/4" = 1'-0"

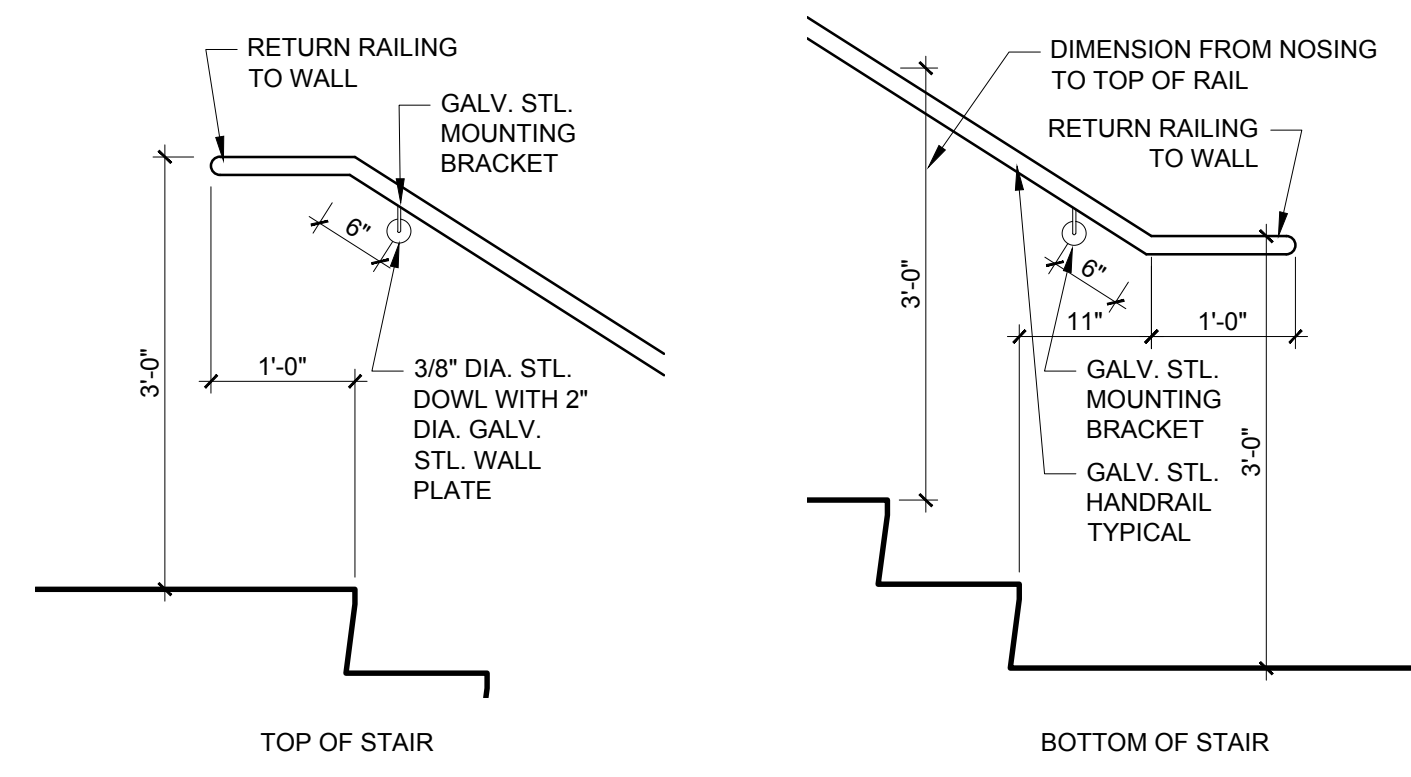

1 TYPICAL RAILING DETAIL AT TOP AND BOTTOM OF STAIR
3/4" = 1'-0"

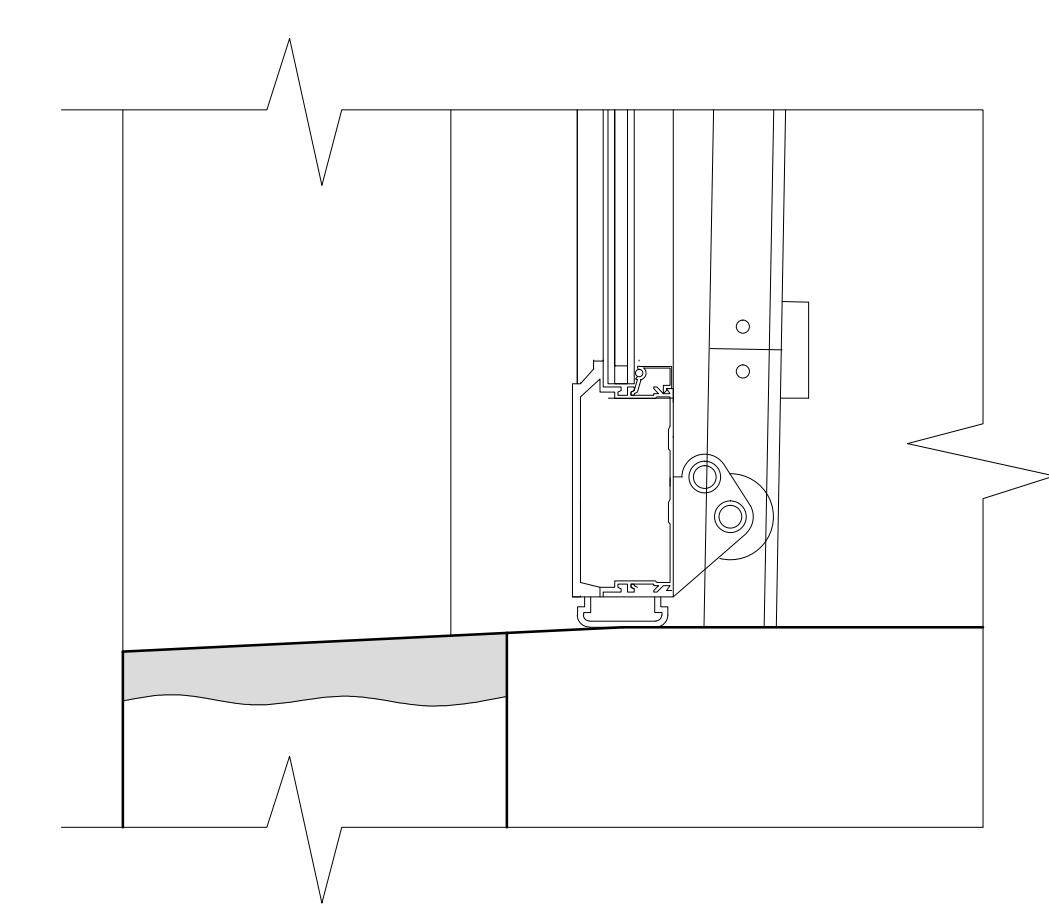

6 SECTION DETAIL AT OVERHEAD DOOR SILL
3/4" = 1'-0"

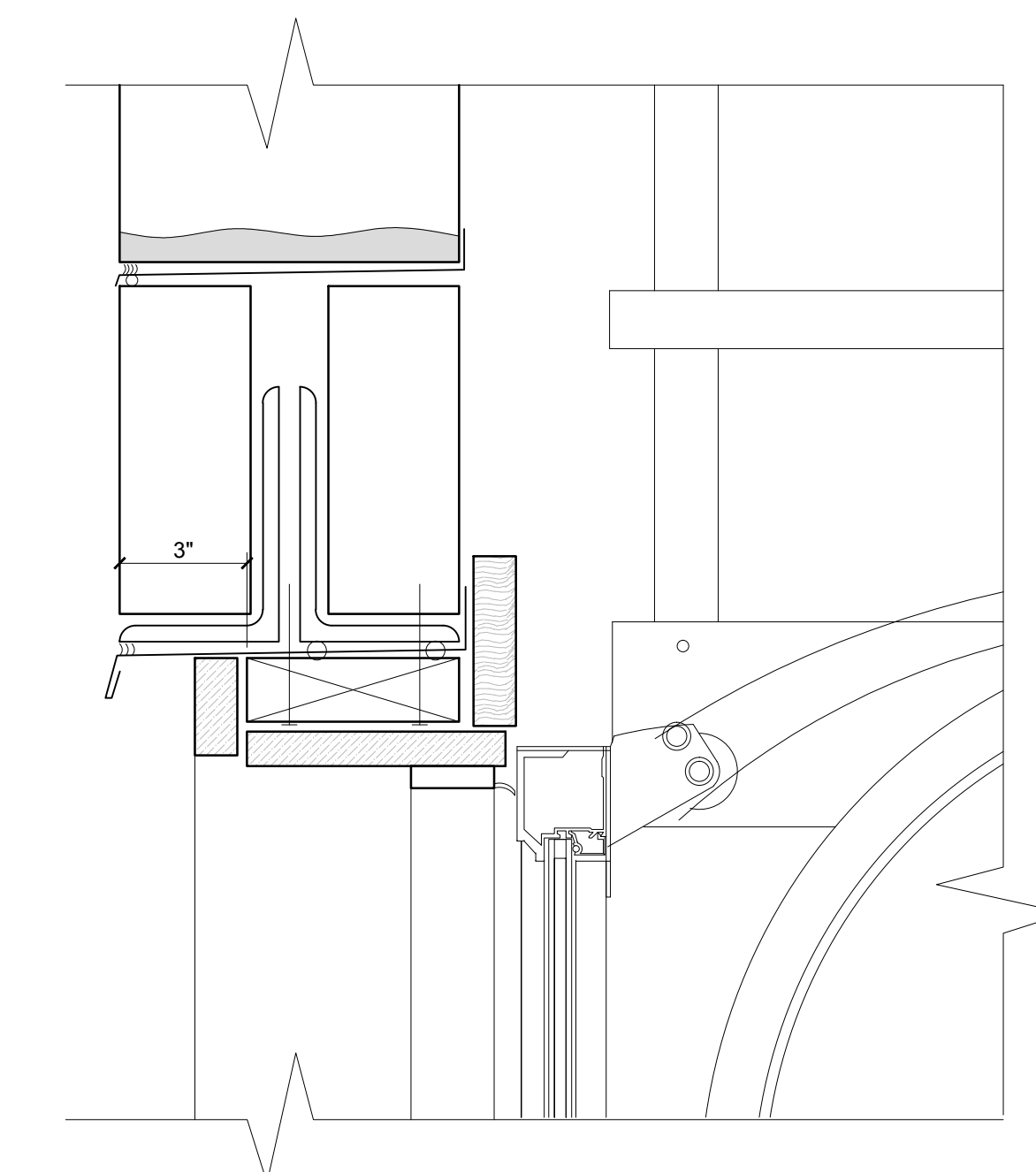

7 SECTION DETAIL AT OVERHEAD DOOR HEAD
3/4" = 1'-0"



© 2014 RYAN SENATORE ARCHITECTURE

RENOVATIONS TO
170 ANDERSON STREET
PORTLAND, MAINE



RYAN SENATORE ARCHITECTURE
565 CONGRESS STREET
SUITE 304
PORTLAND, MAINE 04101
207-655-6414
senatorearchitecture.com

CONSULTANTS:
STRUCTURAL: Structural Integrity
77 Oak Street
Portland, ME 04101
207-774-4614

REVISIONS:

DATE: MAY 09, 2014
PROJECT No. 1416
DRAWN BY: RJS / RRT
CHECKED BY: RJS
SCALE: AS NOTED

SHEET TITLE:
DETAILS

A5-0