

UNDERDRAINED SAND FILTER PLAN VIEW

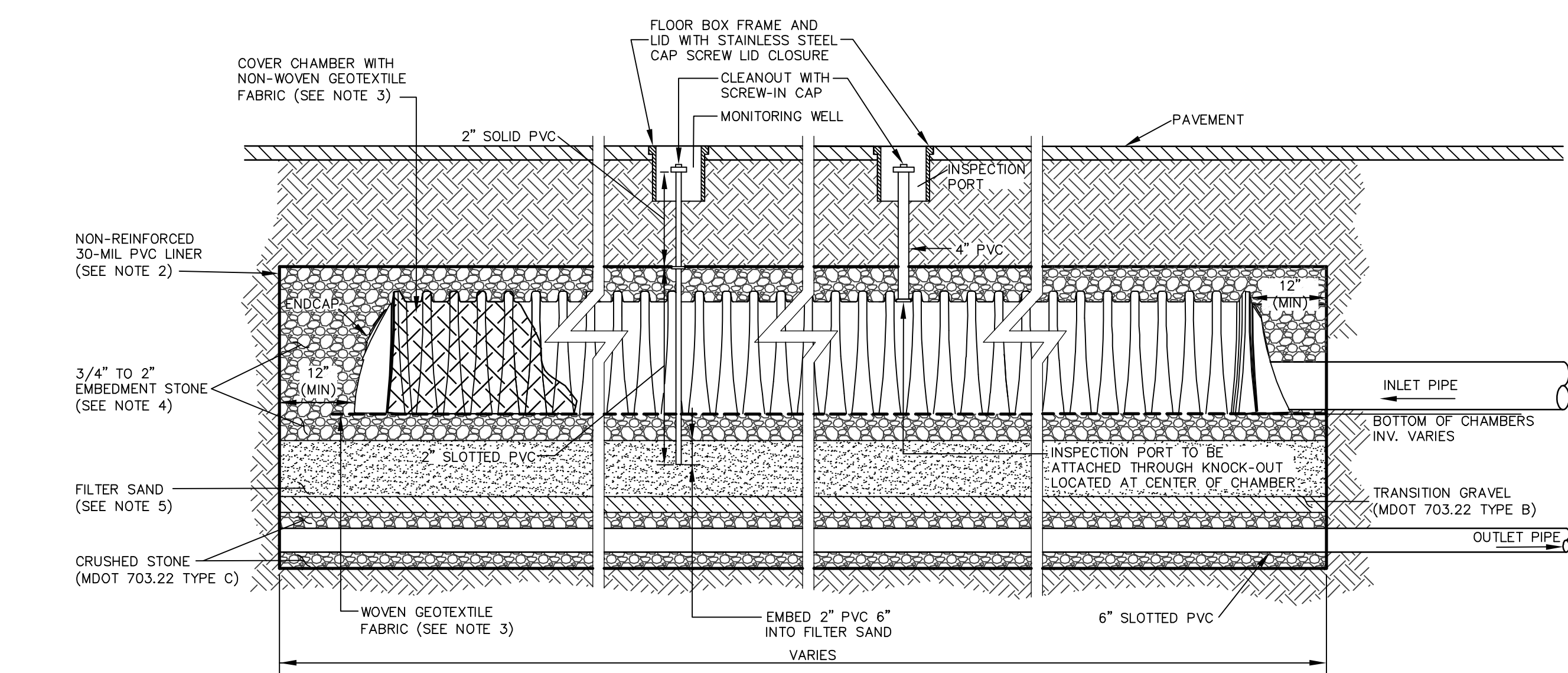

UNDERDRAINED SAND FILTER ELEVATION VIEW

SUBSURFACE UNDERDRAINED SAND FILTER
NOT TO SCALE

SUBSURFACE UNDERDRAINED SAND FILTER NOTES:

1. THE STORMWATER CHAMBER SHALL BE A STORMTECH MC-3500 OR EQUIVALENT SUBSURFACE STORAGE CHAMBER APPROVED BY THE ENGINEER.
2. THE ENTIRE SUBSURFACE SYSTEM, INCLUDING THE CRUSHED STONE STORAGE VOLUME, THE FILTER MEDIA, AND UNDERDRAIN MATERIALS, SHALL BE WRAPPED IN A NON-REINFORCED 30-MIL PVC LINER.
3. A STRIP OF WOVEN GEOTEXTILE THAT MEETS AASHTO M288 CLASS ONE REQUIREMENTS (MIRAFI FW404 OR EQUIVALENT) MUST BE PLACED BETWEEN THE BOTTOM OF THE CHAMBER AND ITS STONE FOUNDATION. THIS FABRIC TRAPS SEDIMENTS AND PROTECTS THE UNDERLYING CRUSHED STONE. A SECOND STRIP OF NON-WOVEN AASHTO M288 CLASS 2 GEOTEXTILE (MIRAFI 160N OR EQUIVALENT) SHALL BE DRAPED OVER THE ENTIRE LENGTH OF THE CHAMBERS. THIS FABRIC WILL ALSO TRAP SEDIMENTS AND PROVIDE SEPARATION BETWEEN THE CHAMBERS AND SURROUNDING STONE.
4. THE EMBEDMENT STONE SURROUNDING THE CHAMBERS SHALL BE A WASHED, ANGULAR STONE WITH THE MAJORITY OF PARTICLES BETWEEN 3/4 INCH AND 2 INCH. THE BOTTOM 6 INCH LAYER OF STONE THAT ACTS AS THE FOUNDATION BELOW THE CHAMBERS SHALL BE COMPACTED TO ACHIEVE A 95% STANDARD PROCTOR DENSITY.
5. THE SAND FILTER MATERIAL SHALL BE A UNIFORM MIX, FREE OF STONES LARGER THAN 2 INCHES, STUMPS, ROOTS, OR OTHER SIMILAR OBJECTS. THE MATERIAL SHALL MEET THE SPECIFICATIONS FOR MDOT AGGREGATE SAND (MDOT #703.01). HOWEVER, THIS AGGREGATE SAND SHALL BE MIXED WITH LOAM TO ACHIEVE A MATERIAL WITH BETWEEN 8% AND 10% PASSING THE #200 SIEVE. THE LOAM USED IN THIS MIXTURE SHALL HAVE A MINIMAL CLAY CONTENT. THIS 18 INCH LAYER OF SAND FILTRATION MEDIA SHALL BE PLACED TO ACHIEVE A LEVEL OF COMPACTION BETWEEN 92% AND 95% STANDARD PROCTOR DENSITY.

CONSTRUCTION OVERSIGHT NOTES FOR SUBSURFACE SAND FILTER:

1. INSPECTIONS BY A PROFESSIONAL ENGINEER SHALL CONSIST OF WEEKLY VISITS TO THE SITE TO INSPECT THE CONSTRUCTION AND STABILIZATION OF THE PROPOSED SUBSURFACE CHAMBERS AND ITS FILTER COURSE MATERIAL TO BE BUILT ON THE SITE. INSPECTIONS SHALL CONSIST OF AN APPROPRIATE NUMBER OF VISITS TO THE SITE TO INSPECT THE INSTALLATION OF THE SUBGRADE, FILTER BED MATERIAL PLACEMENT, INSTALLATION OF STONE, ISOLATOR ROW AND CHAMBER, SURROUNDING STONE, FABRIC LAYOUT AND STORMWATER OVERFLOW BYPASS CONSTRUCTION FROM INITIAL GROUND DISTURBANCE TO FINAL PAVEMENT PLACEMENT.

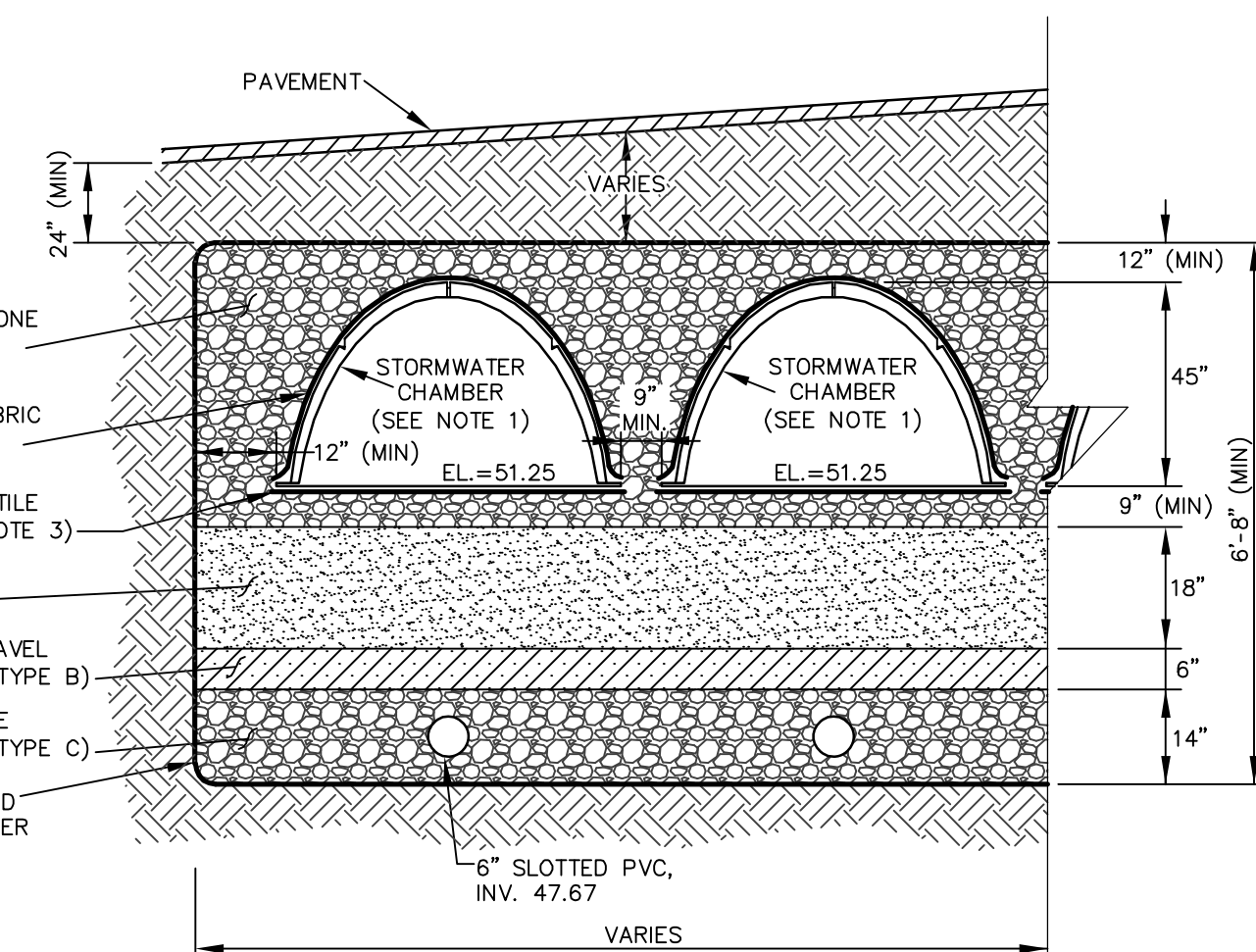

UNDERDRAINED SAND FILTER SECTION

HOUSEKEEPING:

- SPILL PREVENTION:** CONTROLS MUST BE USED TO PREVENT POLLUTANTS FROM BEING DISCHARGED FROM MATERIALS ON-SITE, INCLUDING STORAGE PRACTICES TO MINIMIZE EXPOSURE OF THE MATERIALS TO STORMWATER, AND APPROPRIATE SPILL PREVENTION, CONTAINMENT, AND RESPONSE PLANNING AND IMPLEMENTATION.
- GROUNDWATER PROTECTION:** DURING CONSTRUCTION, LIQUID PETROLEUM PRODUCTS AND OTHER HAZARDOUS MATERIALS WITH THE POTENTIAL TO CONTAMINATE GROUNDWATER MAY NOT BE STORED OR HANDLED IN AREAS OF THE SITE DRAINING TO AN INFILTRATION AREA. AN "INFILTRATION AREA" IS ANY AREA OF THE SITE THAT BY DESIGN OR AS A RESULT OF SOILS, TOPOGRAPHY AND OTHER RELEVANT FACTORS, ACCUMULATES RUNOFF THAT INFILTRATES INTO THE SOIL. DIKES, BERMS, SUMPS, AND OTHER FORMS OF SECONDARY CONTAINMENT THAT PREVENT DISCHARGE TO GROUNDWATER MAY BE USED TO ISOLATE PORTIONS OF THE SITE FOR THE PURPOSES OF STORAGE AND HANDLING OF THESE MATERIALS.
- FUGITIVE SEDIMENT AND DUST:** ACTIONS MUST BE TAKEN TO INSURE THAT ACTIVITIES DO NOT RESULT IN NOTICEABLE EROSION OF SOILS OR FUGITIVE DUST EMISSIONS DURING OR AFTER CONSTRUCTION. OIL MAY NOT BE USED FOR DUST CONTROL.
- DEBRIS AND OTHER MATERIALS:** LITTER, CONSTRUCTION DEBRIS, AND CHEMICALS EXPOSED TO STORMWATER MUST BE PREVENTED FROM BECOMING A POLLUTANT SOURCE.
- TRENCH DEWATERING:** TRENCH DEWATERING IS THE REMOVAL OF WATER FROM TRENCHES, FOUNDATIONS, COFFERDAMS, PONDS, AND OTHER AREAS WITHIN THE CONSTRUCTION AREA THAT RETAIN WATER AFTER EXCAVATION. IN MOST CASES, THE COLLECTED WATER IS HEAVILY SILTED AND HINDERS CORRECT AND SAFE CONSTRUCTION PRACTICES. THE COLLECTED WATER MUST BE REMOVED FROM THE PONDED AREA, EITHER THROUGH GRAVITY OR PUMPING, AND MUST BE SPREAD THROUGH NATURAL WOODED BUFFERS OR REMOVED TO AREAS THAT ARE SPECIFICALLY DESIGNED TO COLLECT THE MAXIMUM AMOUNT OF SEDIMENT POSSIBLE, LIKE A COFFERDAM SEDIMENTATION BASIN. AVOID ALLOWING THE WATER TO FLOW OVER DISTURBED AREAS OF THE SITE. EQUIVALENT MEASURES MAY BE TAKEN IF APPROVED.

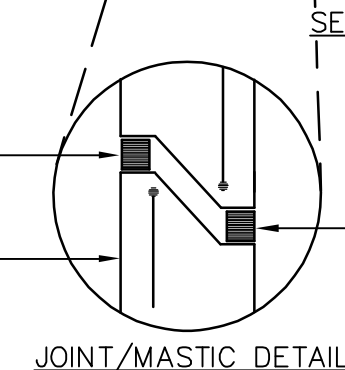
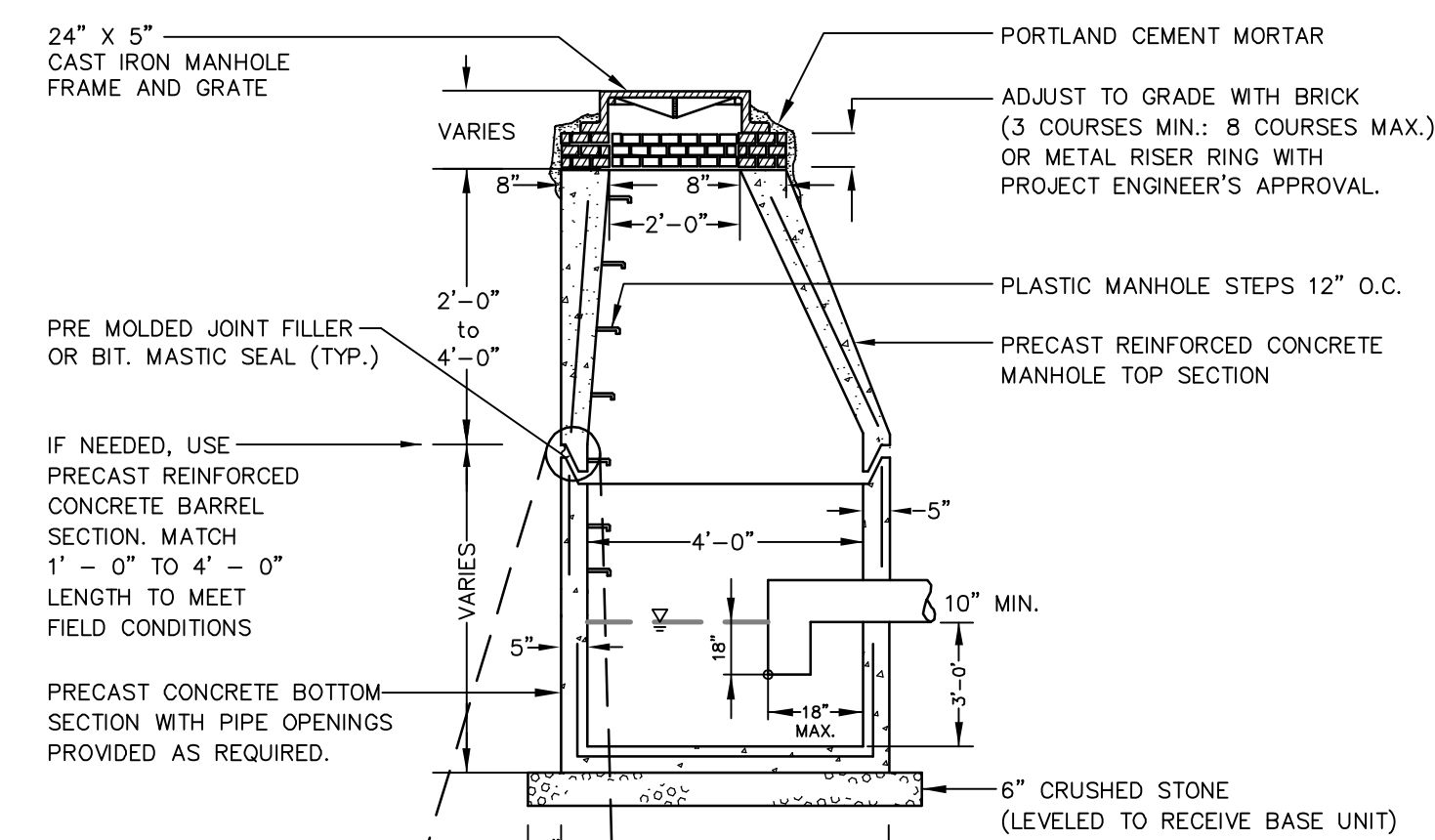

OIL / GRIT SEPARATOR
NOT TO SCALE

- NOTES:**
1. 4'-0" I.D. TYPICAL. SOME STRUCTURES MAY REQUIRE LARGER I.D. PROVIDE SHOP DRAWINGS.
 2. DRAINAGE STRUCTURES TO BE DESIGNED FOR H=20 LOADING.
 3. PIPE SIZES AND INVERTS AS NOTED ON PLANS.
 4. CATCH BASIN FRAME AND GRATE TO BE EAST JORDAN FOUNDRY S250, OR APPROVED EQUAL.

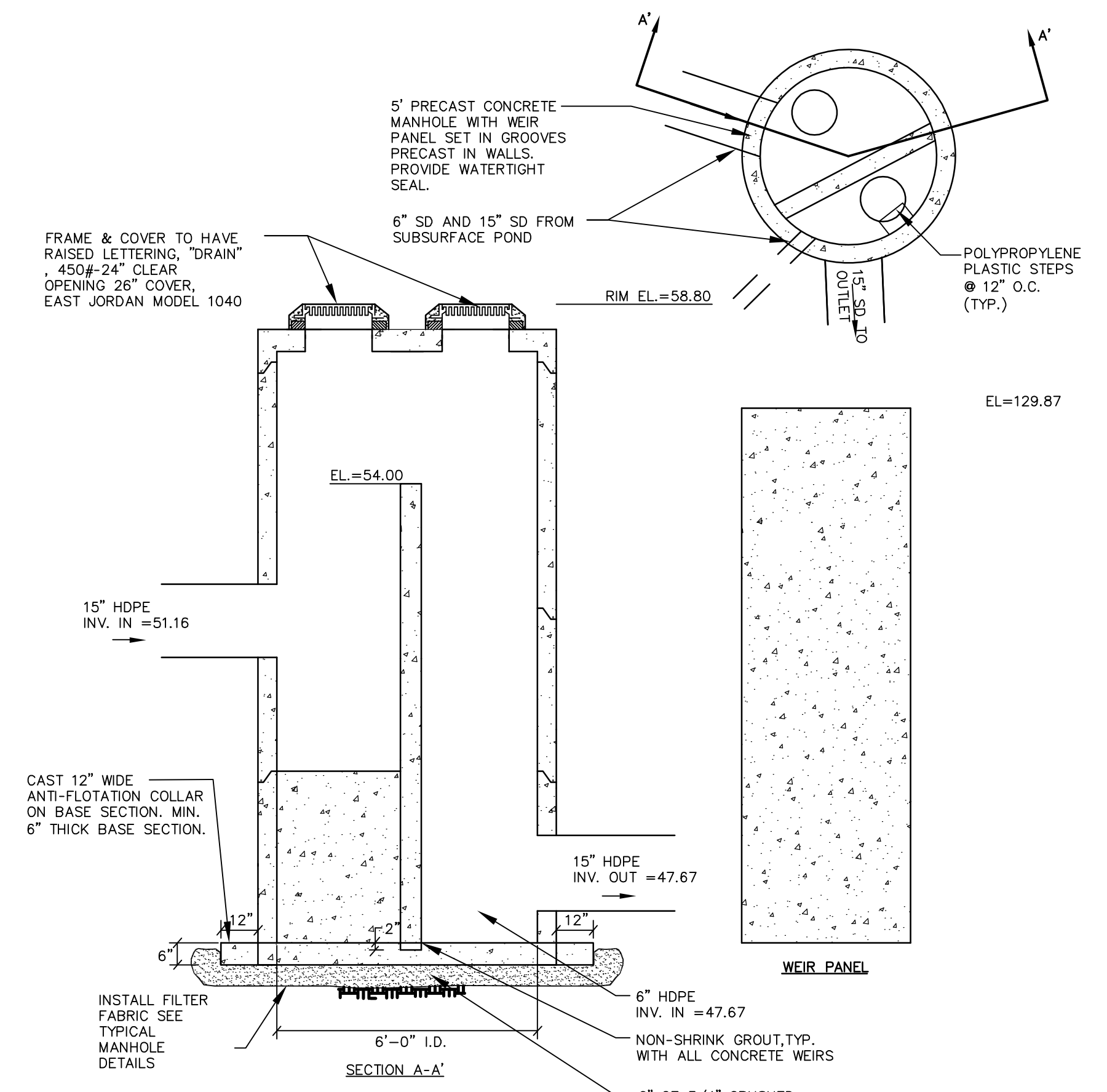

OUTLET CONTROL STRUCTURE (OCS-1)
NOT TO SCALE

NOTE:
SUBMIT SHOP DRAWINGS AND STRUCTURE SPECIFICATIONS FOR OWNER/ENGINEER APPROVAL.

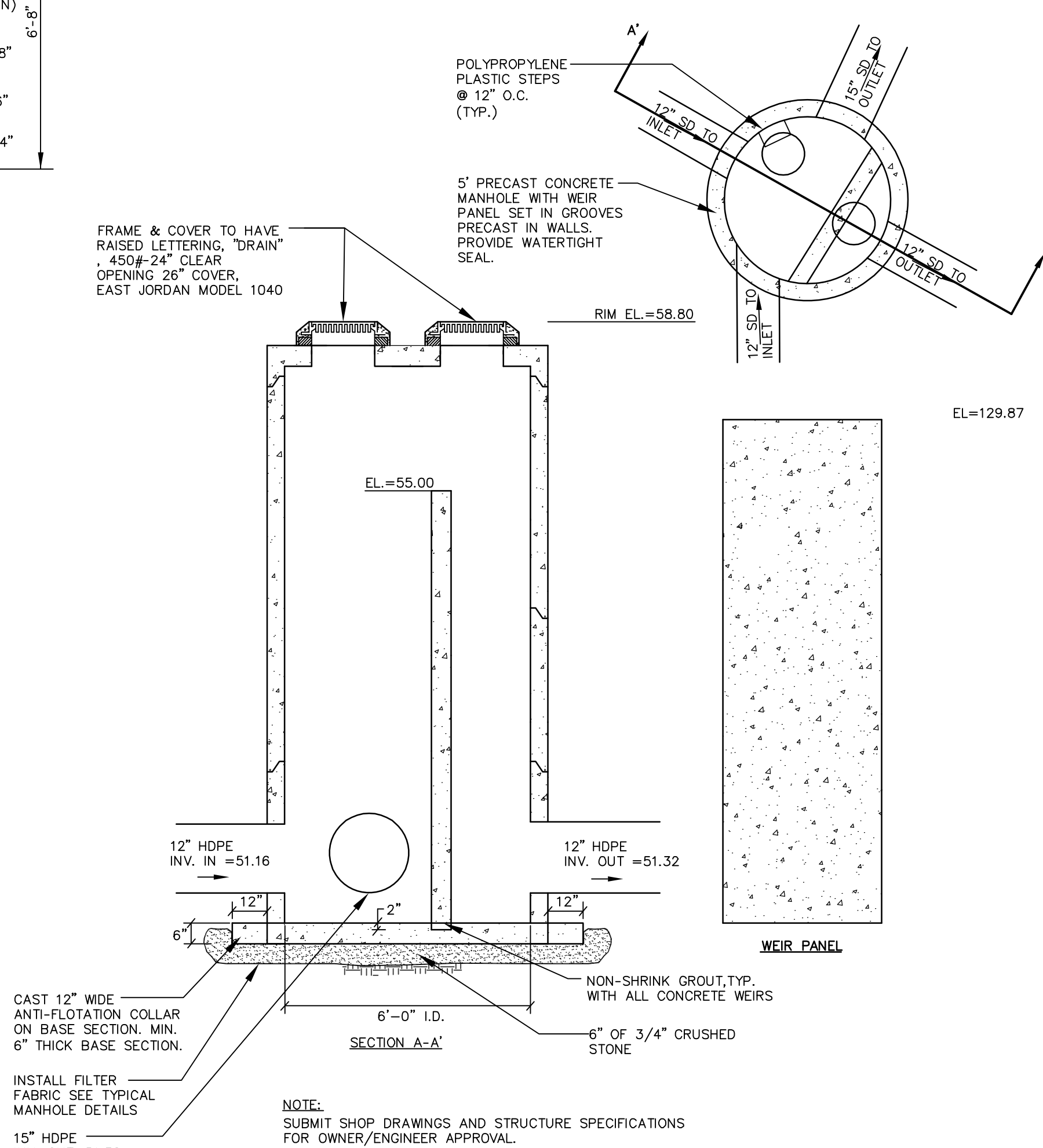

INLET CONTROL STRUCTURE (ICS-1)
NOT TO SCALE

NOTE:
SUBMIT SHOP DRAWINGS AND STRUCTURE SPECIFICATIONS FOR OWNER/ENGINEER APPROVAL.

KEITH D. GRAY, PE #13313

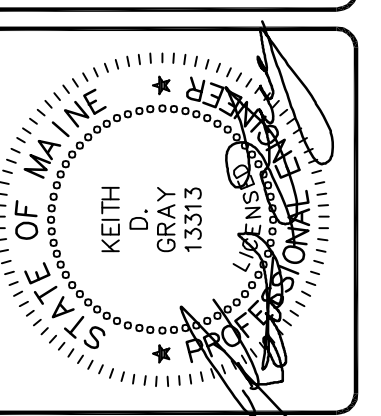

DESIGNED	CHECKED
KDG	KDG
A. WTC 12/15/16 CITY SUBMITTAL NO. 1 REV. BY: DATE: STATUS: THIS PLAN SHALL NOT BE MODIFIED WITHOUT WRITTEN PERMISSION FROM SEBAGO TECHNICS, INC. ANY ALTERATIONS AUTHORIZED OR OTHERWISE, SHALL BE AT THE USER'S SOLE RISK AND WITHOUT LIABILITY TO SEBAGO TECHNICS, INC.	

SEBAGO TECHNICS
 WWW.SEBAGOTECHNICS.COM
 75 John Roberts Rd., Suite 1A
 South Portland, ME 04106
 Tel. 207-200-9100
 250 Goddard Rd., Suite B
 Lewiston, ME 04240
 Tel. 207-783-5656

DETAILS
 OF: 218-220 WASHINGTON AVENUE
 PORTLAND, MAINE
 FOR: 218-220 WASHINGTON AVENUE LLC
 199 ELDERBERRY ROAD
 SOUTH PORTLAND, MAINE 04106

PROJECT NO.	SCALE
06172	AS SHOWN

SHEET 8D OF 23

061720.dwg 146.04