

TYP SLAB DETAIL @ DOOR
N.T.S.

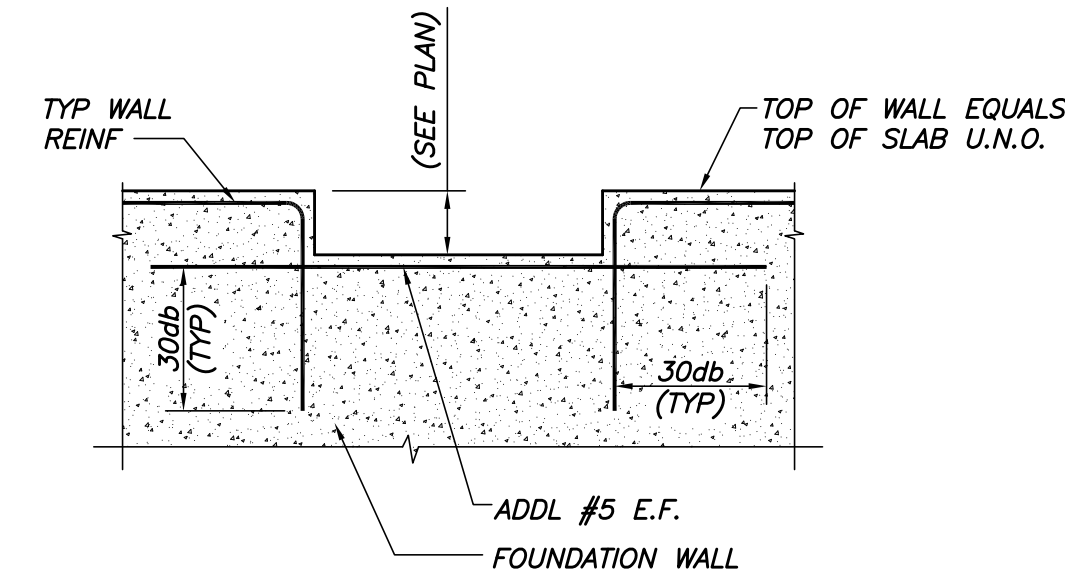

TYP WALL DEPRESSION DETAIL @ DOOR
N.T.S.

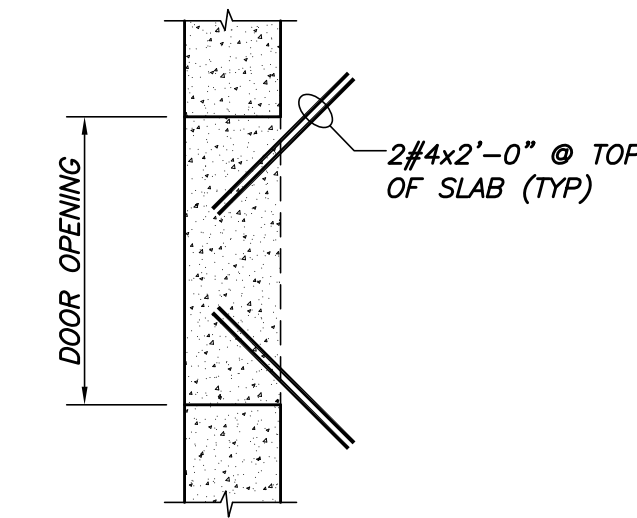

TYP SLAB CORNER DETAIL @ DOOR
N.T.S.

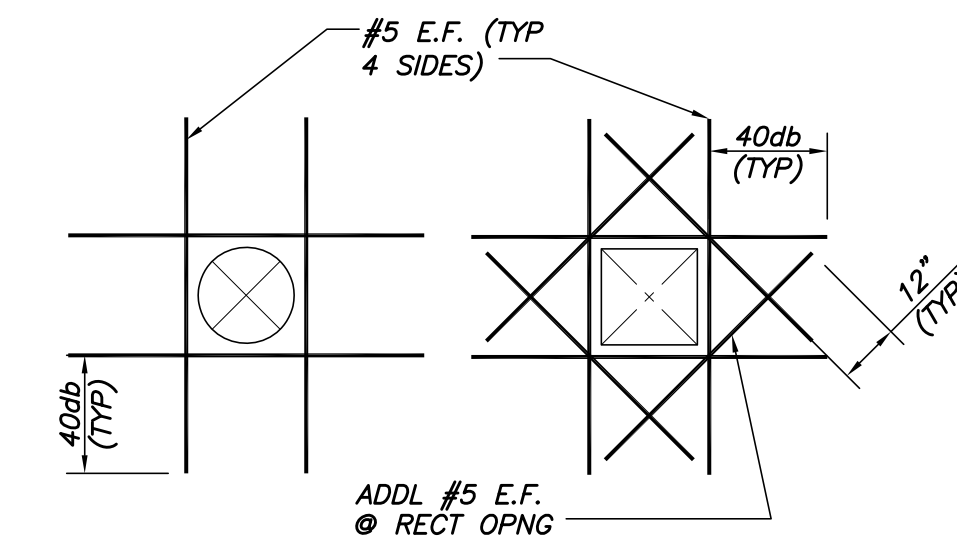

TYP OPENING IN WALL OR SLAB DETAIL
N.T.S.

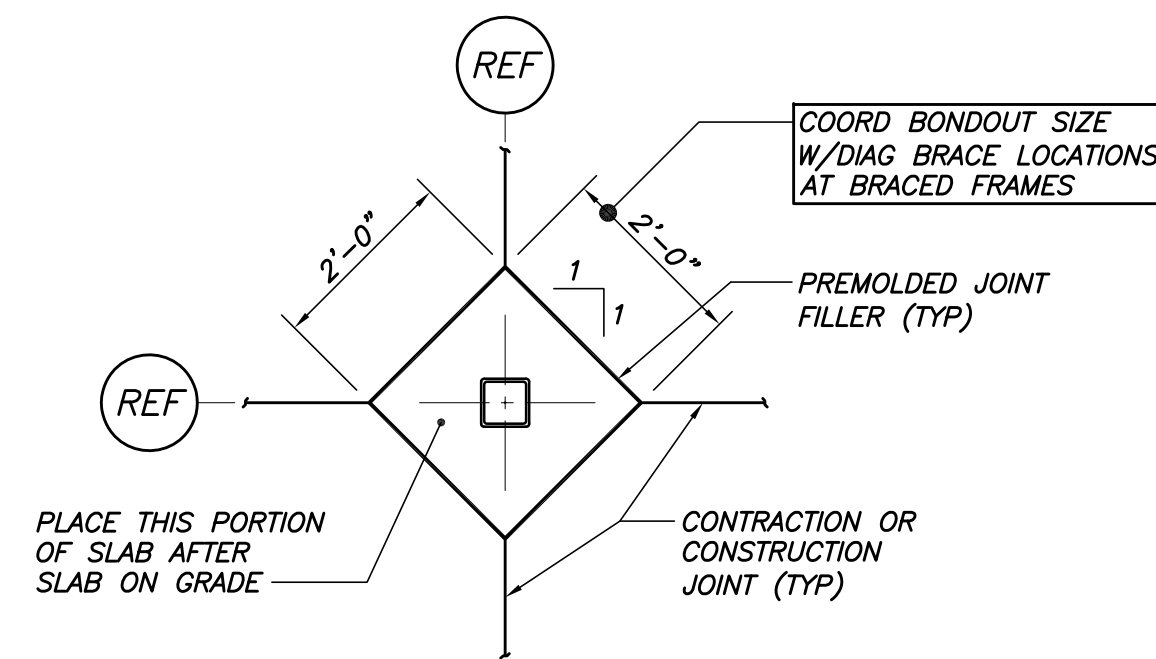

TYP INT COLUMN ISOLATION
JOINT DETAIL
N.T.S.

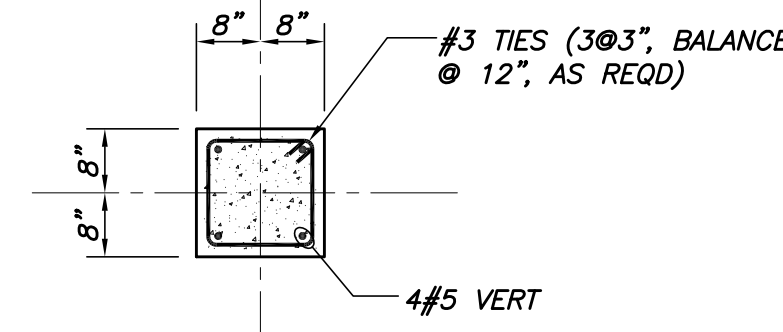

P1 PIER DETAIL

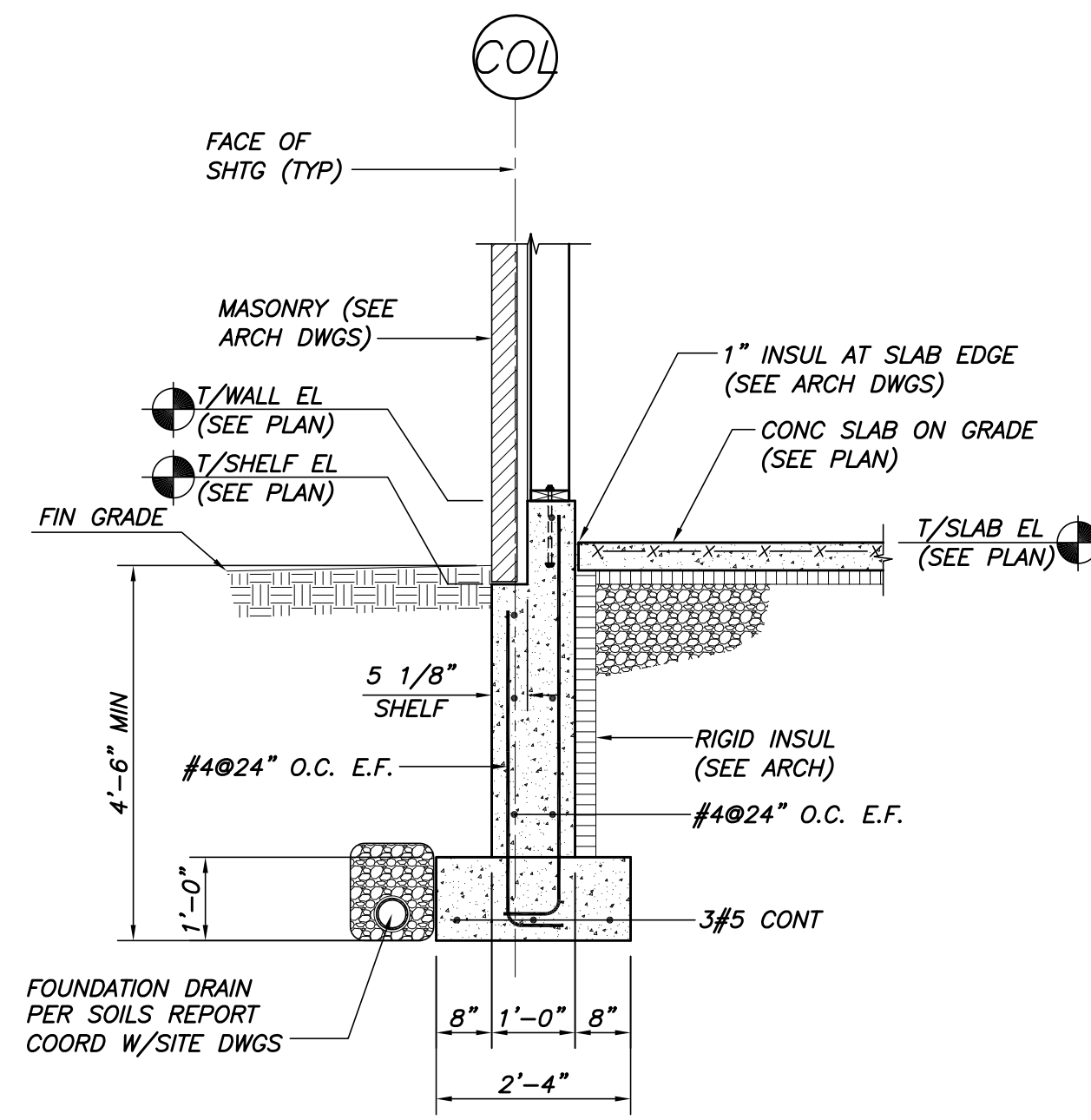

SECTION 1
1/2"=1'-0" S1.0

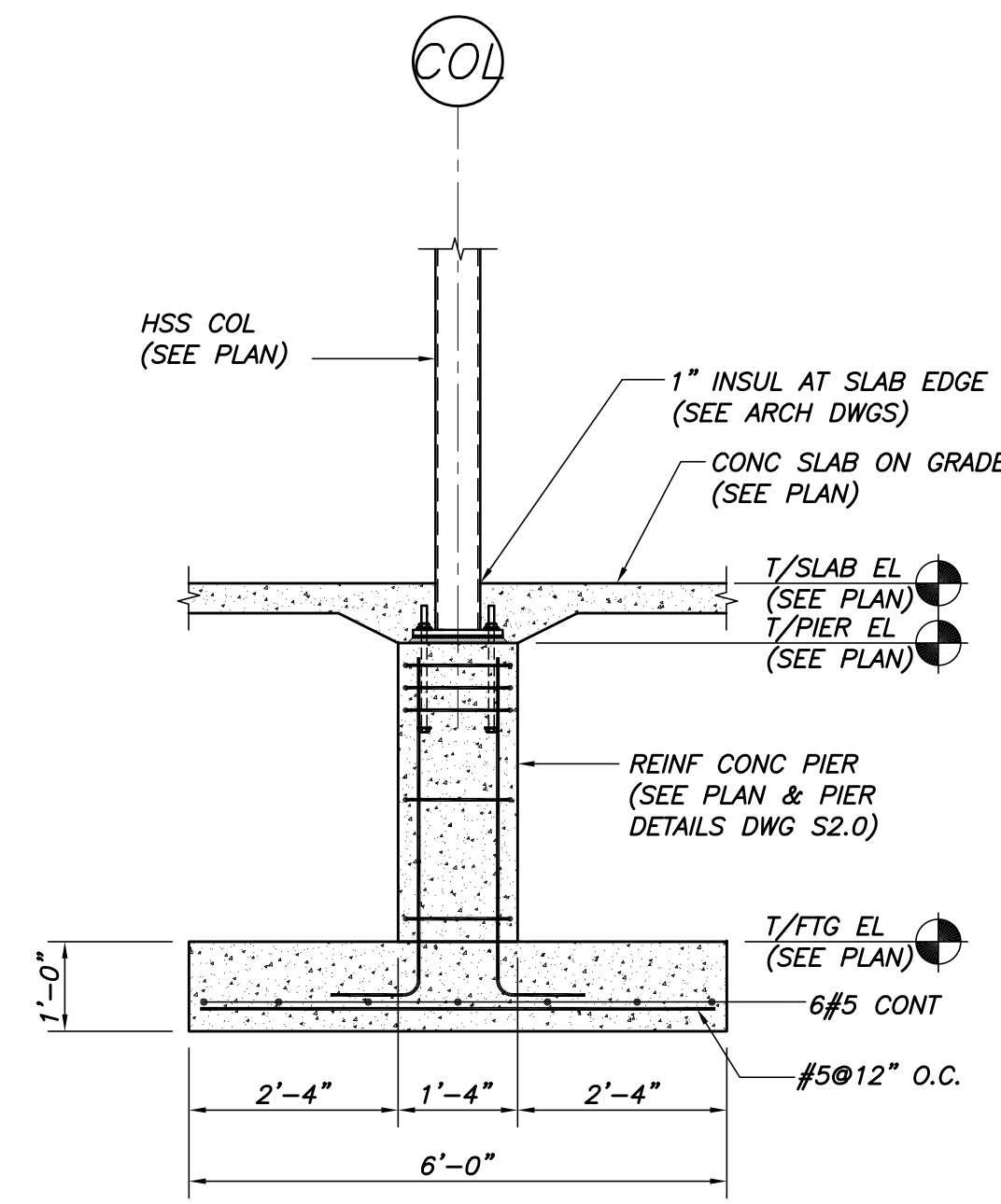

SECTION 2
1/2"=1'-0" S1.1

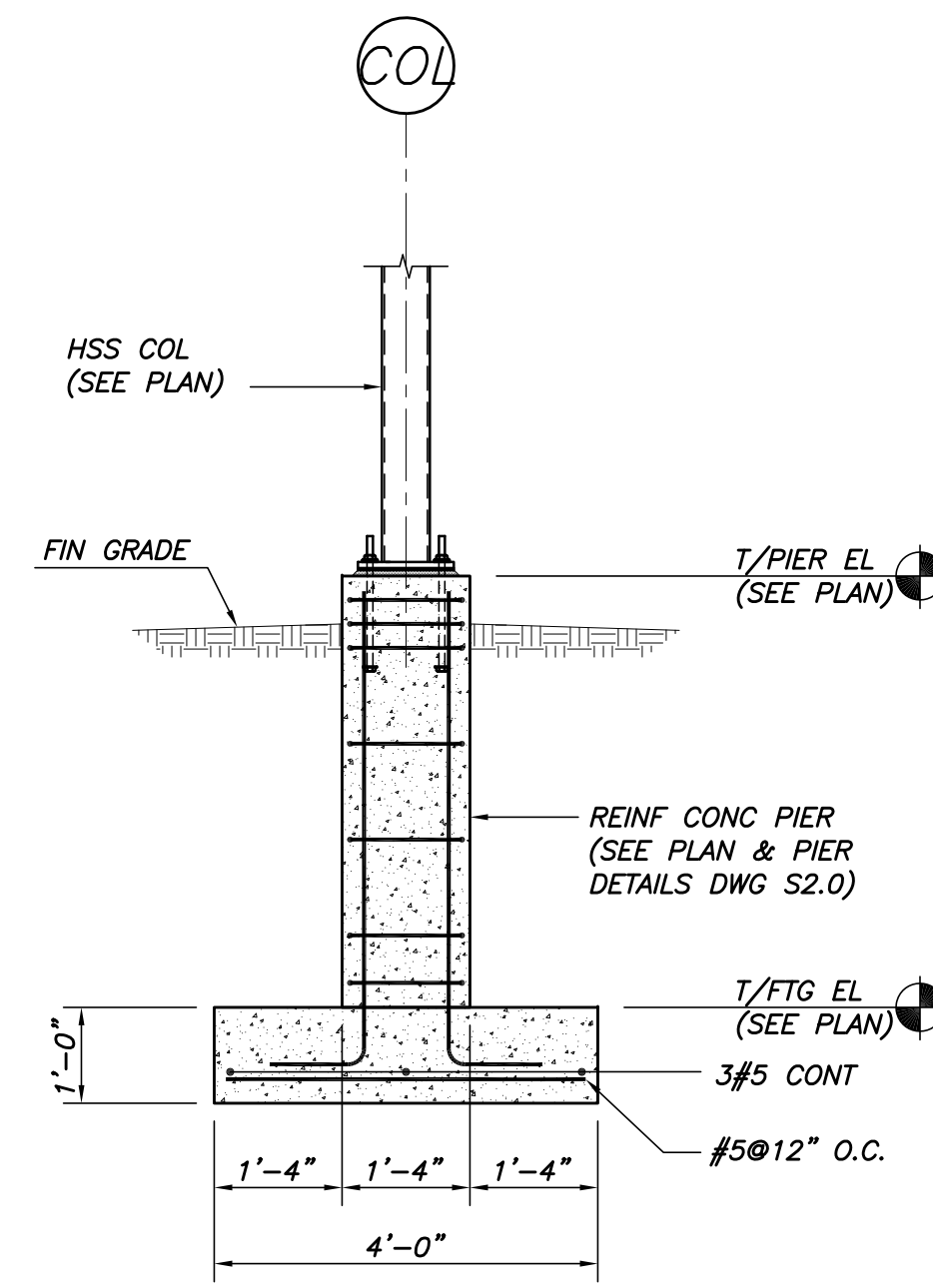

SECTION 3
1/2"=1'-0" S1.1

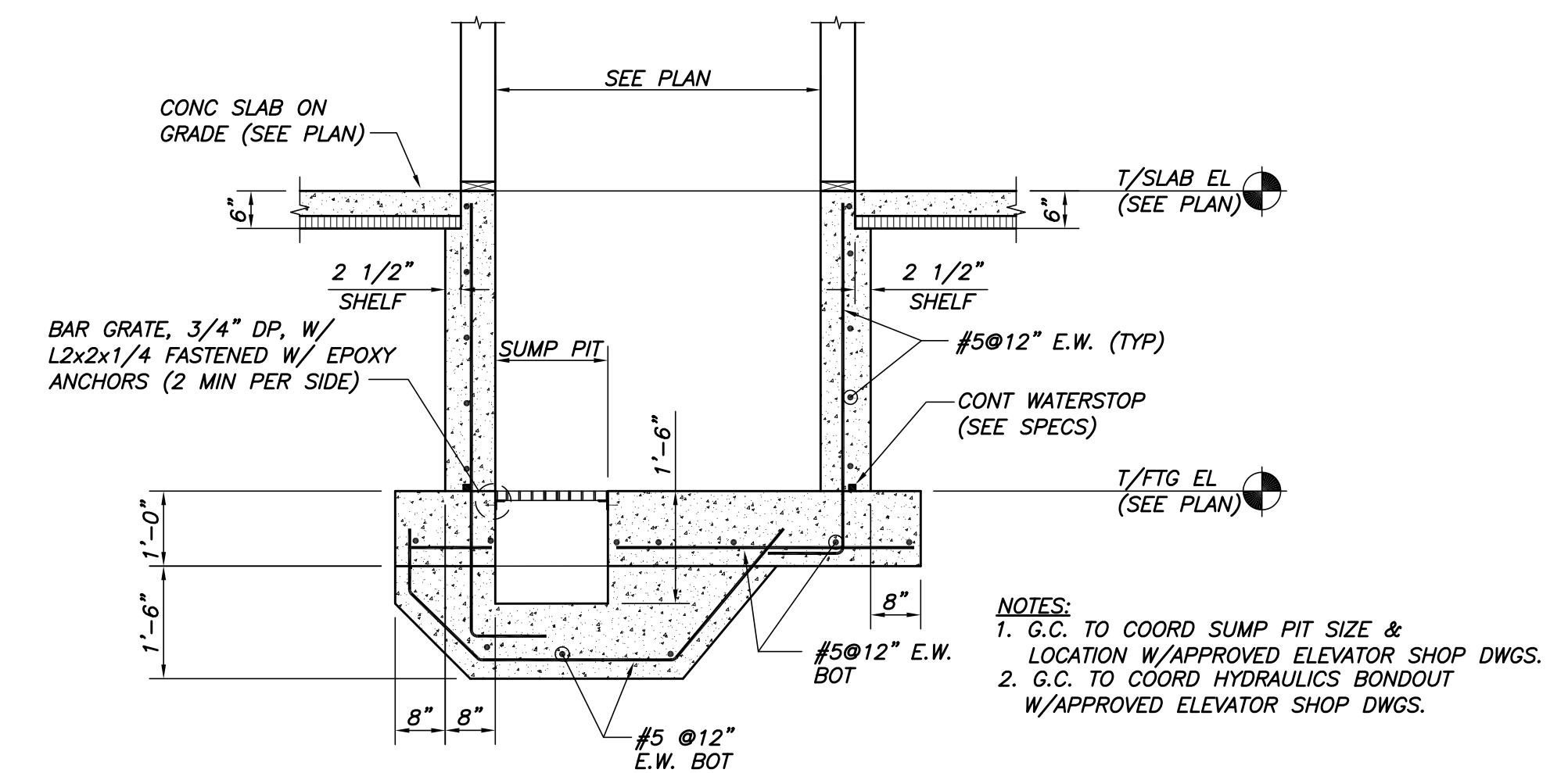

SECTION 4
1/2"=1'-0" S1.1

NOTES:
1. G.C. TO COORD SUMP PIT SIZE & LOCATION W/APPROVED ELEVATOR SHOP DWGS.
2. G.C. TO COORD HYDRAULICS BONDOUT W/APPROVED ELEVATOR SHOP DWGS.

THIS DRAWING IS AN INSTRUMENT OF SERVICE AND SHALL REMAIN THE PROPERTY OF BECKER STRUCTURAL ENGINEERS, INC. IT SHALL NOT BE REPRODUCED, COPIED, LENT, OR DISPOSED OF DIRECTLY OR INDIRECTLY, NOR USED FOR ANY PURPOSE OTHER THAN FOR WHICH IT IS SPECIFICALLY FURNISHED AND MUST BE RETURNED TO BECKER STRUCTURAL ENGINEERS, INC. ON COMPLETION OF WORK, IF REQUESTED.

Approved	
Issued For	
Date	
Rev. No	

BRADY RESIDENCE
9 MOODY STREET
PORTLAND, ME 04101
TYPICAL DETAILS & SECTIONS

Designed	RTN	Scale	AS NOTED
Drawn	RJB	Date	1/8/18
Checked	PBB	Becker Job Number	4196

NOT FOR CONSTRUCTION
100% DD SET
01/08/18

THESE DWGS ARE NOT COMPLETE.
DESIGN IS STILL IN PROGRESS.
CONTRACTOR SHALL CARRY
APPROPRIATE CONTINGENCY.

S2.0