

slope of EPDM roofing
 1/4"=1'-0"

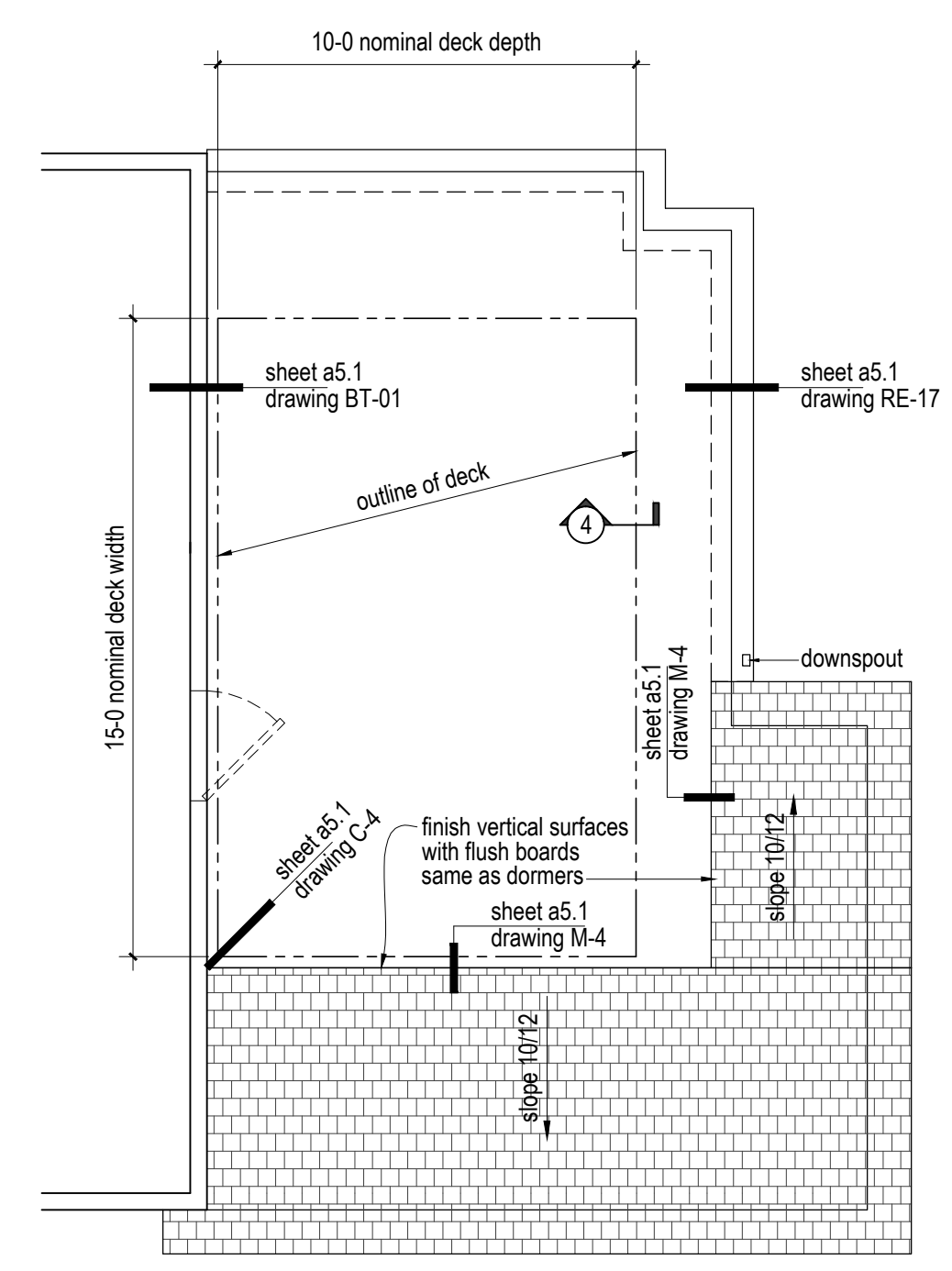

3rd floor roof plan
 1/4"=1'-0"

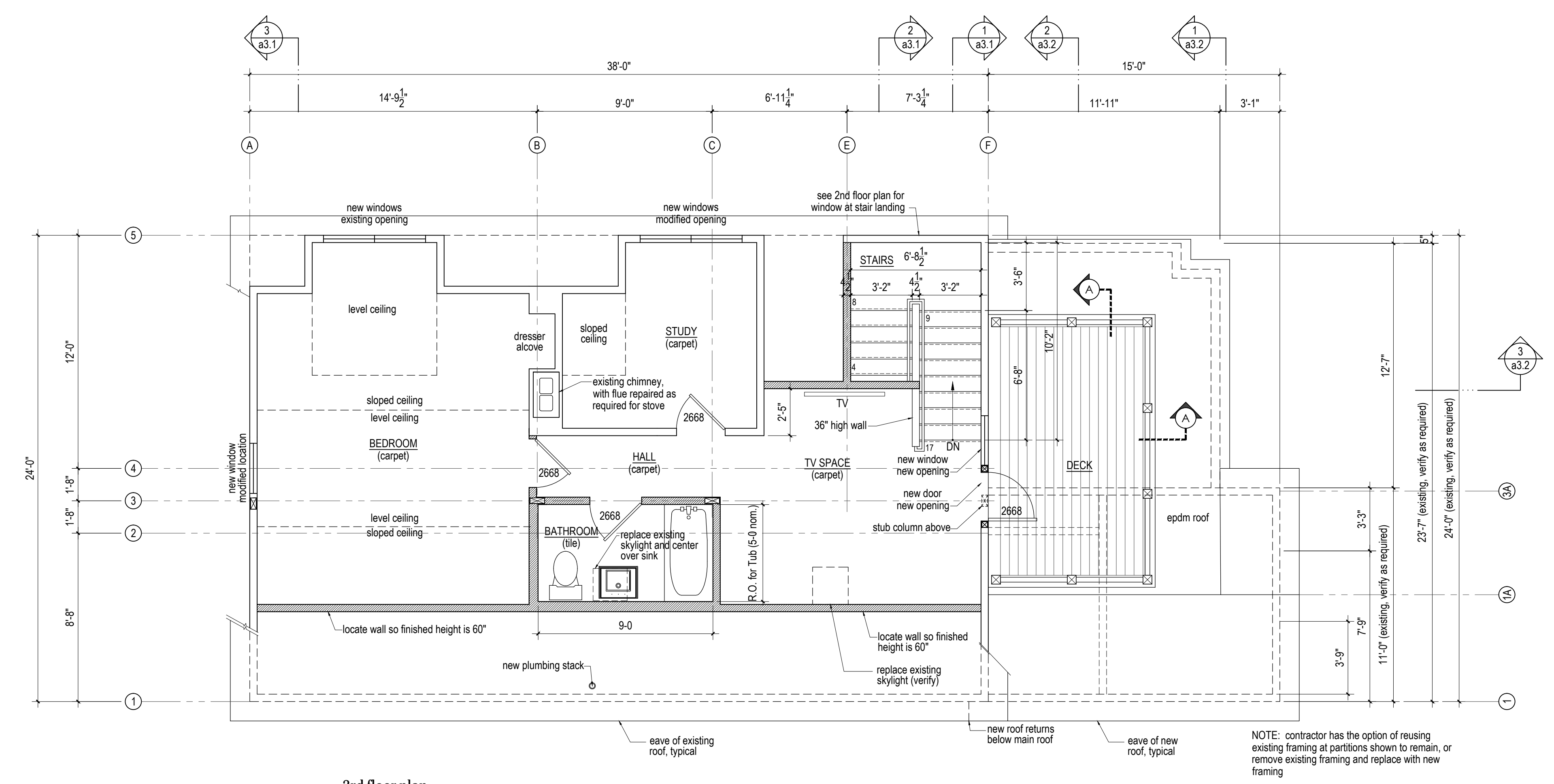

3rd floor plan
 1/4"=1'-0"

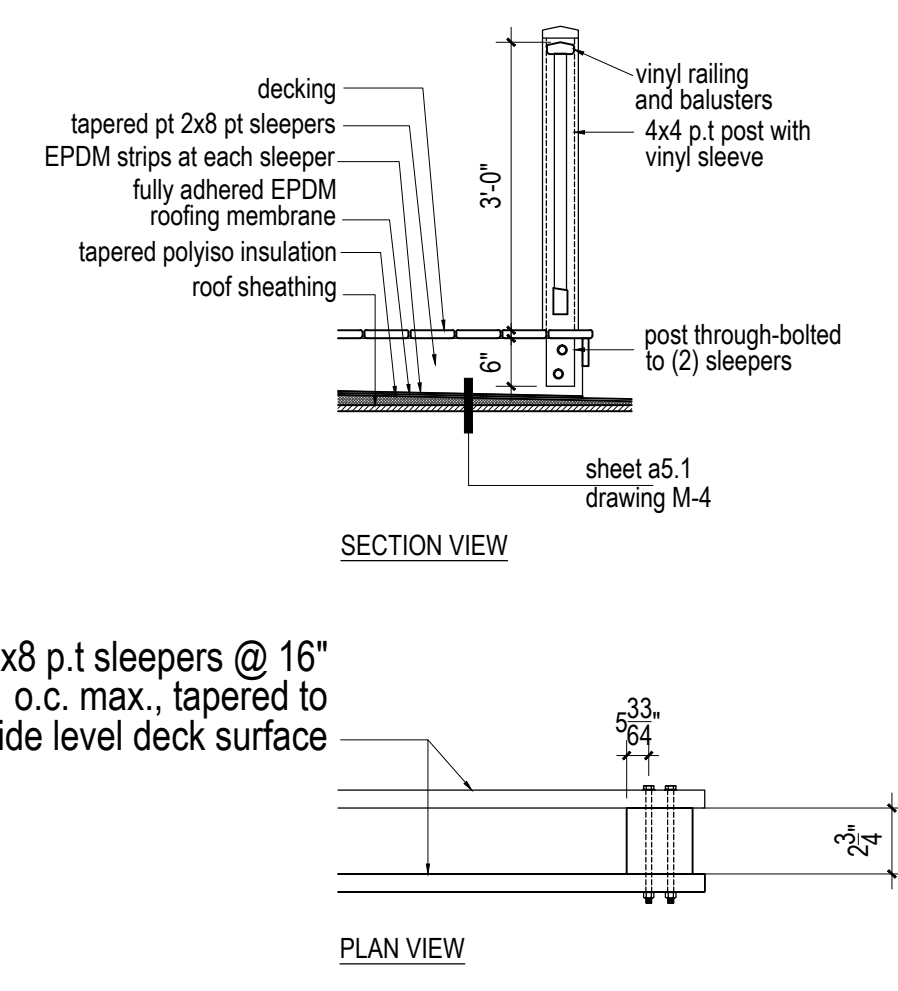

A Roof Deck Railing Detail
 1/2"=1'-0"

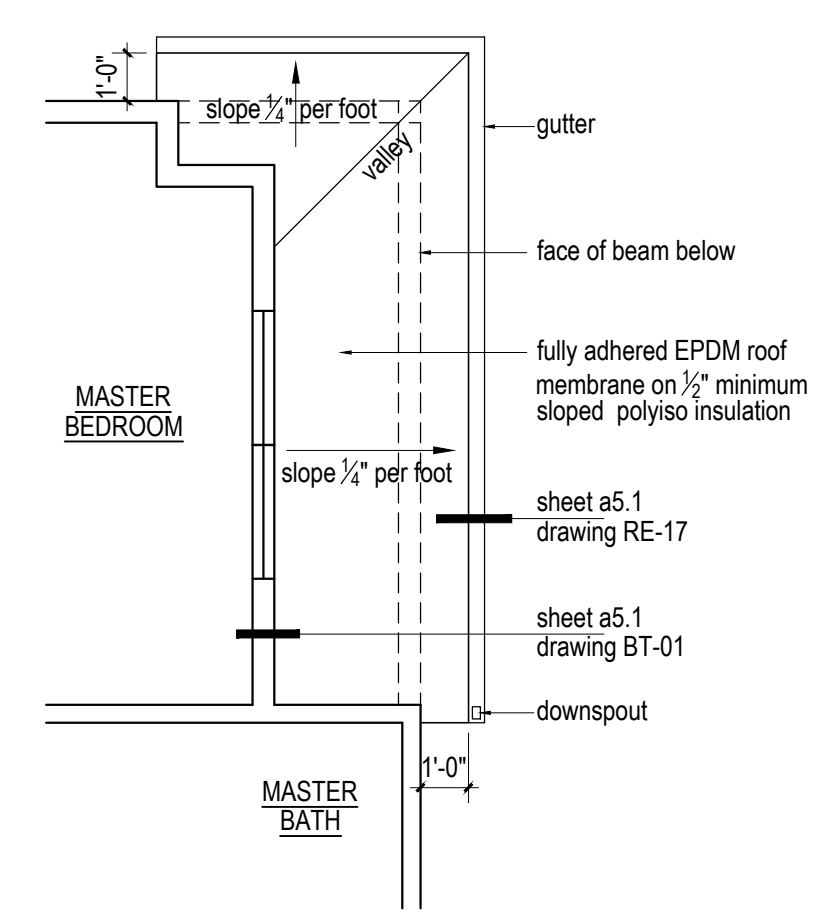

Porch roof plan at 2nd floor
 1/4"=1'-0"

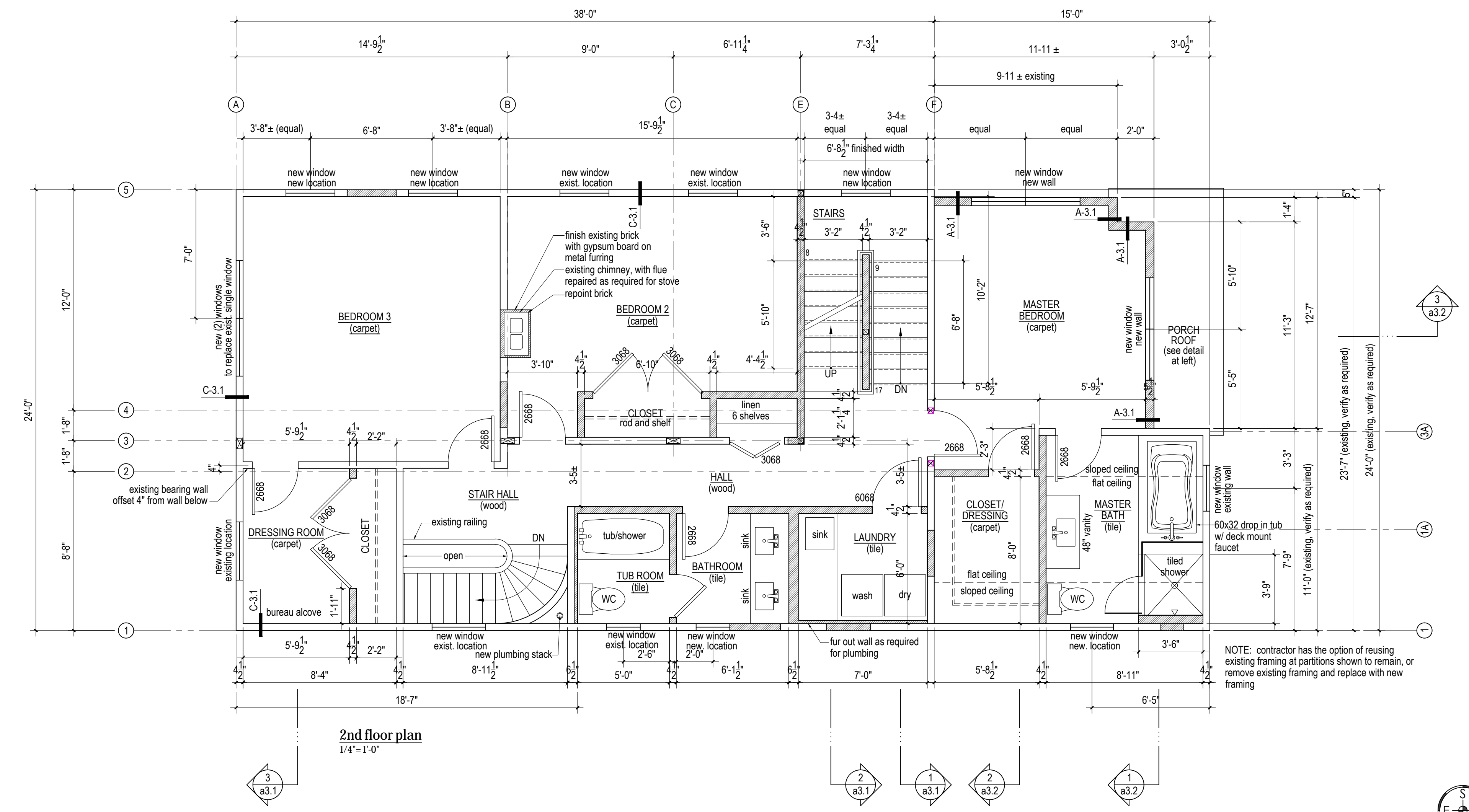

2nd floor plan
 1/4"=1'-0"



NOTE: contractor has the option of reusing existing framing at partitions shown to remain, or remove existing framing and replace with new framing

NOTE: contractor has the option of reusing existing framing at partitions shown to remain, or remove existing framing and replace with new framing