

SUBMITTAL DATA: MSZ-FH09NA & MUZ-FH09NA
 9,000 BTU/H WALL-MOUNTED HEAT PUMP SYSTEM

Job Name:	Location:	Date:
Purchaser:	Engineer:	
Submitted to:	For <input type="checkbox"/> Reference <input type="checkbox"/> Approval <input type="checkbox"/> Construction	
System Designation:	Schedule No.:	

GENERAL FEATURES

- Highly energy-efficient system that features 100% heating capacity at 5°F, 82% at -4°F, and 62% at -13°F
- Updated sleek, compact indoor unit design
- Includes Standard, Platinum Deodorizing, and Anti-allergy Enzyme filters for a complete air purifying system
- “Powerful Mode” function permits system to temporarily run at a lower/higher temperature with an increased fan speed, which quickly brings the room to the optimum comfort level
- Integrated i-see Sensor automatically adjusts the unit’s operation according to temperature differences detected between the floor and the intake air, ensuring optimum comfort and energy usage
- Hand-held Wireless Remote Controller
- Base heater is available as an option
- Limited warranty: five years parts and seven years compressors

ACCESSORIES
Outdoor Unit

- Base Heater (MAC-640BH-U)
- Drain Socket (MAC-851DS)

Indoor Unit

- Condensate Pump (BlueDiamond X87-711/721; 115/230V)
- Condensate Pump (Sauermann SI30-115/230; 115/230V)
- Replacement Platinum Deodorizing Filter (MAC-3000FT-E)
- Replacement Anti-allergy Enzyme Filter ((MAC-2330FT-E)

Controller Options

- Wireless Wall-mounted Remote Controller Kit (MHK1)*
 - Portable Central Controller (MCCH1)*
 - Outdoor Air Sensor (MOS1)*
 - Wired Wall-mounted Controller (PAR-31MAA requires MAC-333IF)*
 - Simple MA Remote Controller (PAC-YT53CRAU requires MAC-333IF)*
- *See Submittal for information on each option.
- System Control Interface (MAC-333IF)



SPECIFICATIONS: MSZ-FH09NA & MUZ-FH09NA

Cooling*1

Rated Capacity.....	9,000 Btu/h
Capacity Range.....	1,700 - 12,000 Btu/h
Rated Total Input	560 W
Maximum Total Input	1,000 W
SEER	30.5 Btu/h/W

Heating at 47° F*2

Rated Capacity.....	10,900 Btu/h
Capacity Range.....	1,600 - 18,000 Btu/h
Rated Total Input	710 W
Maximum Total Input	1,470 W
HSPF.....	13.5 Btu/h/W

Heating at 17° F *3

Rated Capacity.....	6,700 Btu/h
Max. Capacity	12,200 Btu/h
Rated Total Input	600 W
Maximum Total Input	1,440 W

Heating at 5° F *4

Max. Capacity	10,900 Btu/h
Maximum Total Input	1,500 W

Rating Conditions:

- *1 Cooling | Indoor: 80° F (27° C) DB / 67° F (19° C) WB
- *1 Cooling | Outdoor: 95° F (35° C) DB / 75° F (24° C) WB
- *2 Heating at 47°F | Indoor: 70° F (21° C) DB / 60° F (16° C) WB
- *2 Heating at 47°F | Outdoor: 47° F (8° C) DB / 43° F (6° C) WB
- *3 Heating at 17° F | Indoor: 70° F (21° C) DB / 60° F (16° C) WB
- *3 Heating at 17° F | Outdoor: 17° F (-8° C) DB / 15° F (-9° C) WB
- *4 Heating at 5° F | Indoor: 70° F (21° C) DB / 60° F (16° C) WB
- *4 Heating at 5° F | Outdoor: 5° F (-15° C) DB / 5° F (-15° C) WB

Electrical Requirements

Power Supply	208 / 230V, 1-Phase, 60 Hz
Breaker Size.....	15 A

Voltage

Indoor - Outdoor S1-S2	AC 208 / 230V
Indoor - Outdoor S2-S3	DC +/- 24V
Indoor - Remote Controller	MKH1 DC 3V
	PAR-31MAA DC 12V
	PAC-YT53CRAU DC 12V

Operating Conditions

Cooling

Indoor Intake Air Temp. . . (Max.)	90° F (32° C) DB / 73° F (23° C) WB
	(Min.) 67° F (19° C) DB / 57° F (14° C) WB

Outdoor Intake Air Temp. (Max.)	115° F (46° C) DB
	(Min.) 14° F (-10° C) DB

Heating

Indoor Intake Air Temp. . . (Max.)	80° F (27° C) DB / 67° F (19° C) WB
	(Min.) 70° F (21° C) DB / 60° F (16° C) WB

Outdoor Intake Air Temp. (Max.)	75° F (24° C) DB / 65° F (18° C) WB
	(Min.) -13° F (-25° C) DB / -15° F (-26° C) WB**

** System cuts out at -18° F (-28° C) to avoid thermistor error, but recovers from cutout operation and automatically restarts at -13° F (-25° C).

Indoor Unit

MCA	1.0 A
Blower Motor (ECM).....	0.67 F.L.A.
Blower Motor Output	30 W

Airflow (Lo - Med - Hi - Super Hi - Powerful)

Cooling	137-167-221-304-381 Dry CFM
	117-143-190-261-328 Wet CFM
Heating.....	140-167-225-325-437 Dry CFM

Sound Pressure Level (Lo - Med - Hi - Super Hi - Powerful)

Cooling	20-23-29-36-40 dB(A)
Heating.....	20-24-29-36-42 dB(A)

External Finish Color	Munsell 1.0Y 9.2/0.2
-----------------------------	----------------------

External Dimensions

Inches:	12 + 11/16 H x 36-7/16 W x 9-3/16 D
mm:	305 +17 H x 925 W x 234 D

Weight Unit.....	29 lbs. / 12 kg
------------------	-----------------

Field Drainpipe Size O.D.....	19/32 In. / 15mm
-------------------------------	------------------

Outdoor Unit

MCA	11 A
Fan Motor (ECM)	0.50 F.L.A.

Sound Pressure Level

Cooling *1.....	48 dB(A)
Heating *2	49 dB(A)

External Finish Color	Munsell 3Y 7.8/1.1
-----------------------------	--------------------

Dimensions

Inches:.....	21-5/8 H x 31-1/2 W x 11-1/4 D
mm:	550 H x 800 W x 285 D

Weight	81 lbs. / 36 kg
--------------	-----------------

Refrigerant Type	R410A
------------------------	-------

Refrigerant Pipe

Gas Side O.D.....	3/8" x 9.52 mm
Liquid Side O.D.....	1/4" x 6.35 mm

Max. Refrigerant Pipe Length

Height Difference	40' / 12m
Length	65' / 20m

Connection Method

Indoor/Outdoor.....	Flared
---------------------	--------

Notes:

DIMENSIONS: MSZ-FH09NA & MUZ-FH09NA

MSZ-FH09NA

Unit: mm (in.)

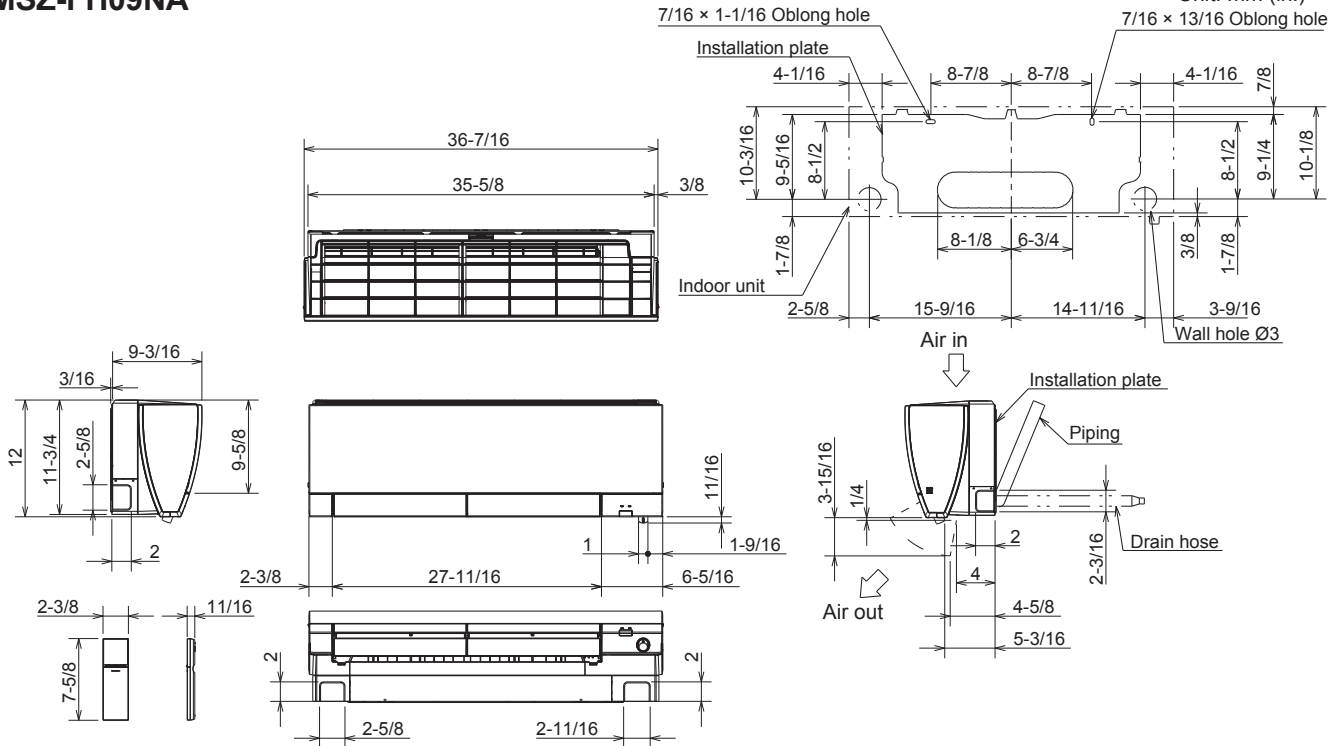

MUZ-FH09NA

Unit: mm (in.)

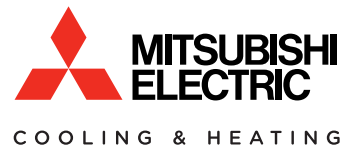
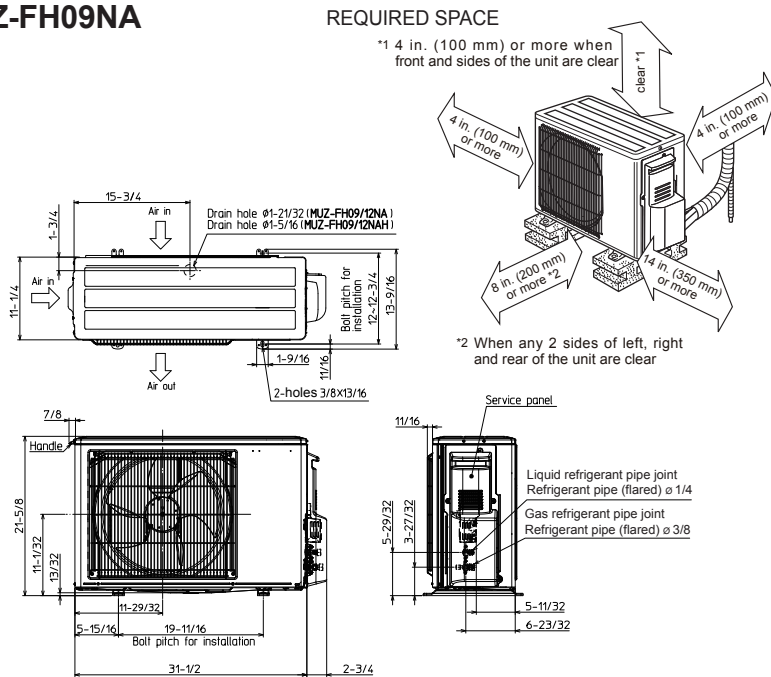

1340 Satellite Boulevard
 Suwanee, GA 30024
 Tele: 678-376-2900 • Fax: 800-889-9904
 Toll Free: 800-433-4822
 www.mehvac.com