

PIPE INSTALLATION DETAIL N.T.S.

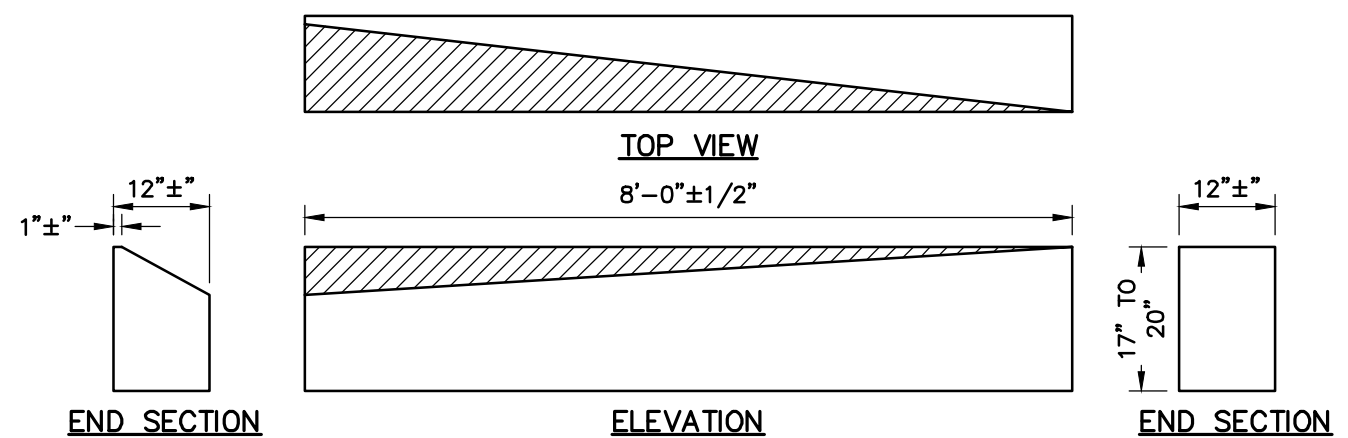

TRANSITION SECTION "B" CURB TYPE "5" TO VERTICAL CURB TYPE "1" CURB TRANSITION N.T.S.

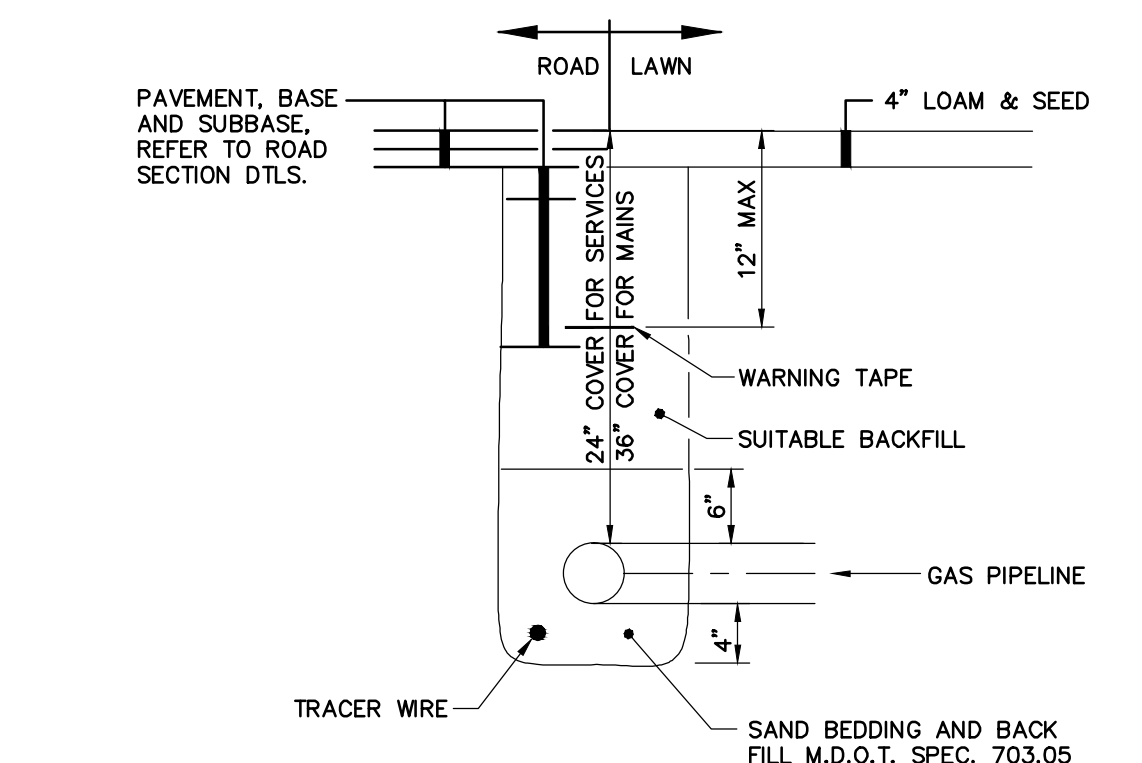

NATURAL GAS PIPE N.T.S.

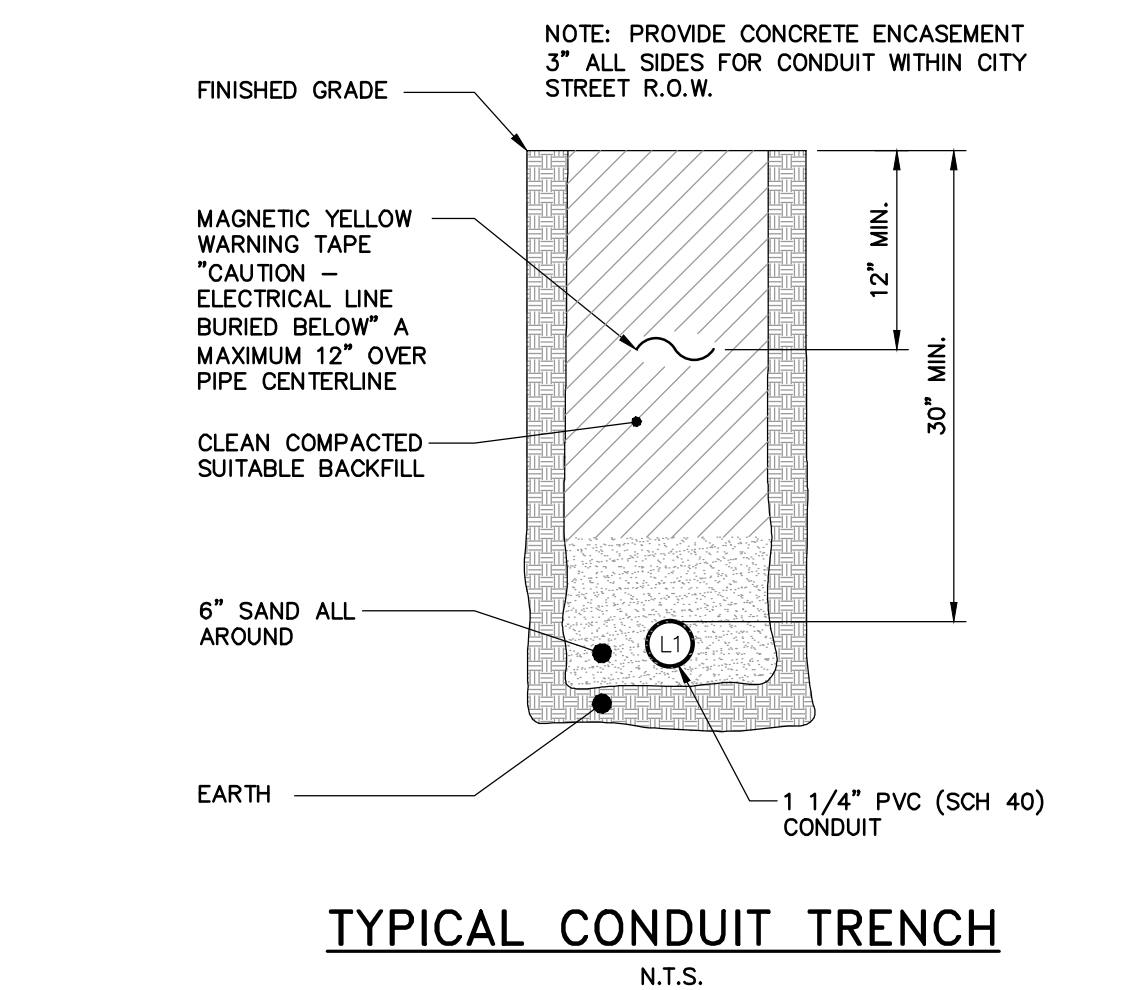

TYPICAL CONDUIT TRENCH N.T.S.

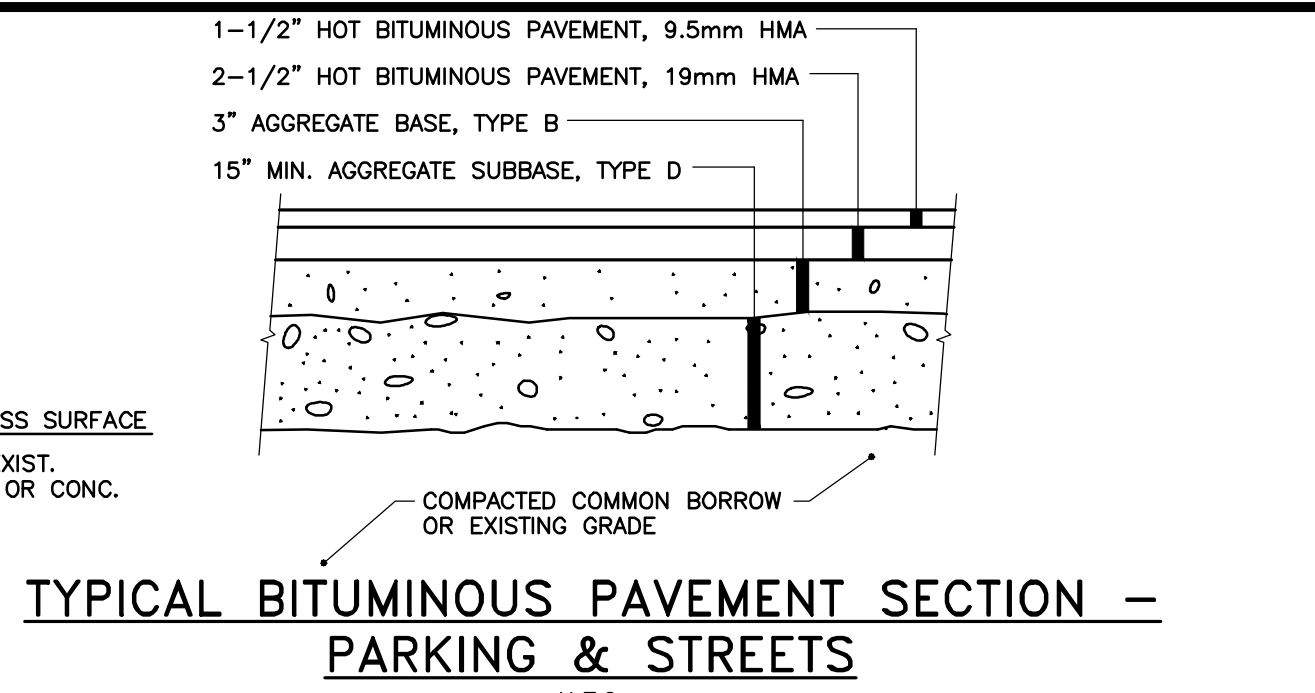

TYPICAL BITUMINOUS PAVEMENT SECTION - PARKING & STREETS N.T.S.

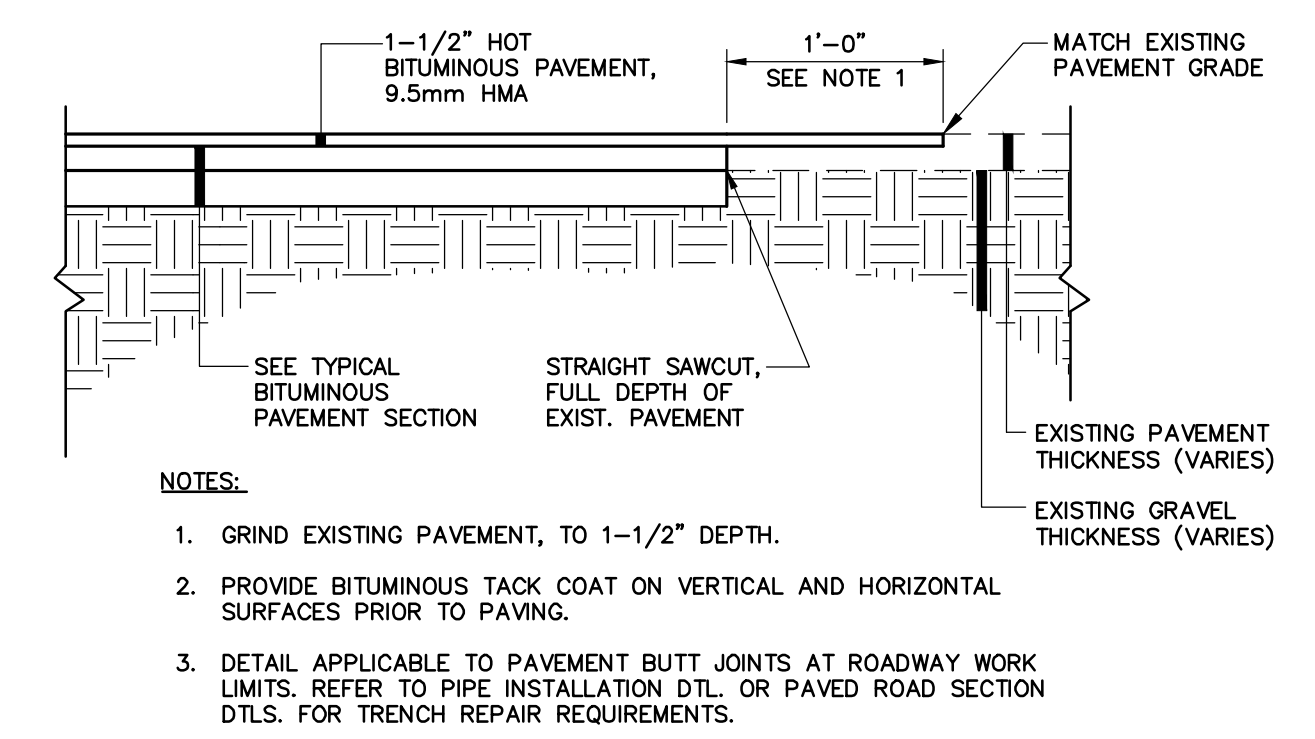

PAVEMENT BUTT JOINT DETAIL N.T.S.

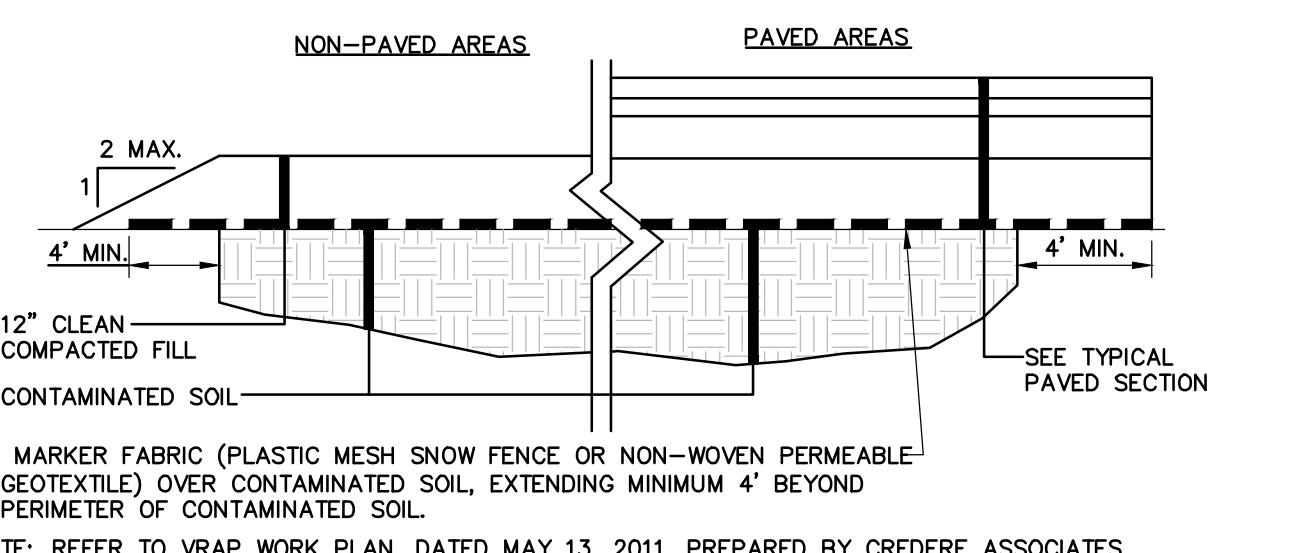

CONTAMINATED SOIL COVERING SECTION N.T.S.

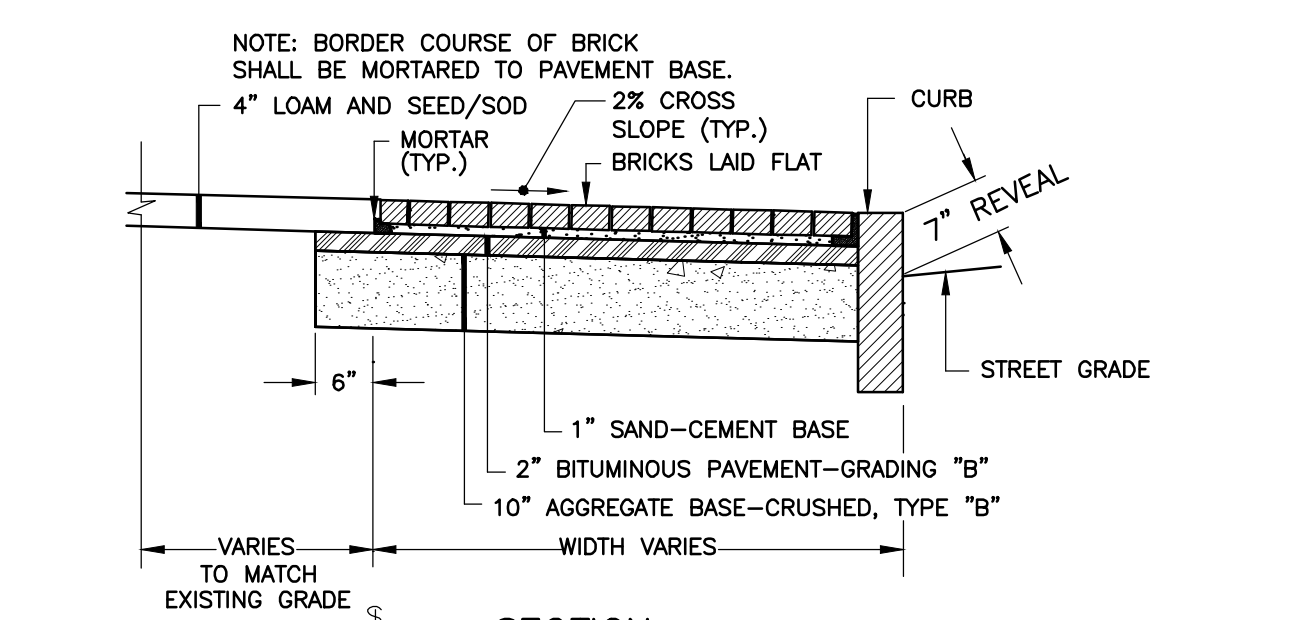

BRICK SIDEWALK DETAIL N.T.S.

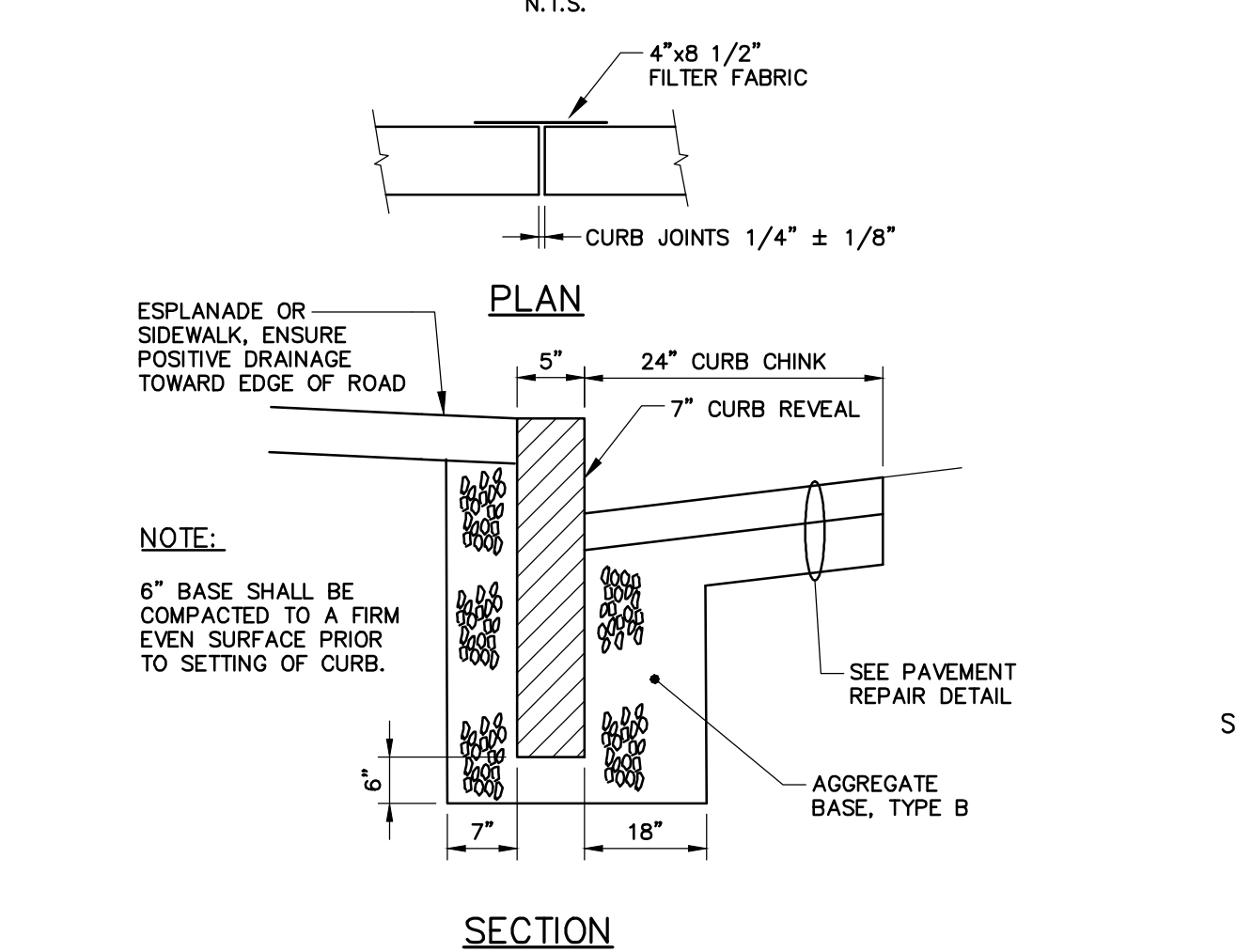

CURB TYPE 1 ON CURVES			
TYPE	RADIUS OF CURVE	LENGTH	STONE IS CUT OR CAST
1	0' TO 60' INCL.	4' MIN.	ARC TO FIT CURVE
	OVER 60' TO 160'	4' TO 6'	STRAIGHT PIECES

TYPICAL NEW AND RESET CURB INSTALLATION N.T.S. NOTE: AGGREGATE TYPES PER MDOT SECTION 304.02

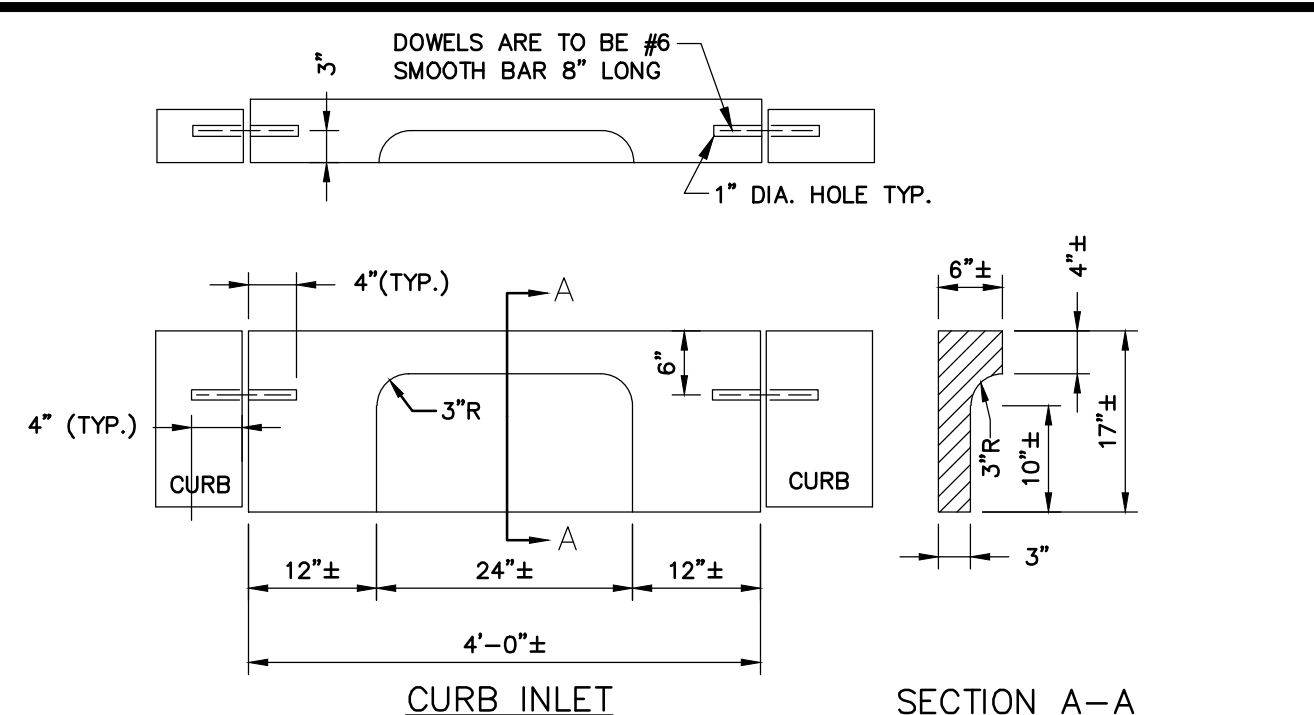

TYPE 1 GRANITE CURB INLET N.T.S.

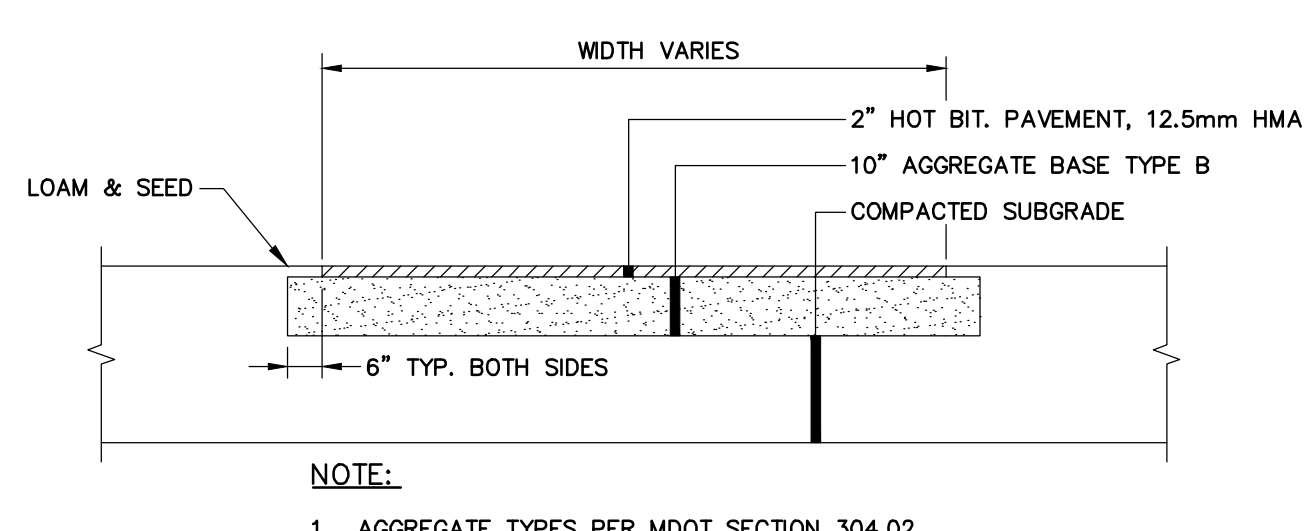

BITUMINOUS SIDEWALK DETAIL N.T.S.

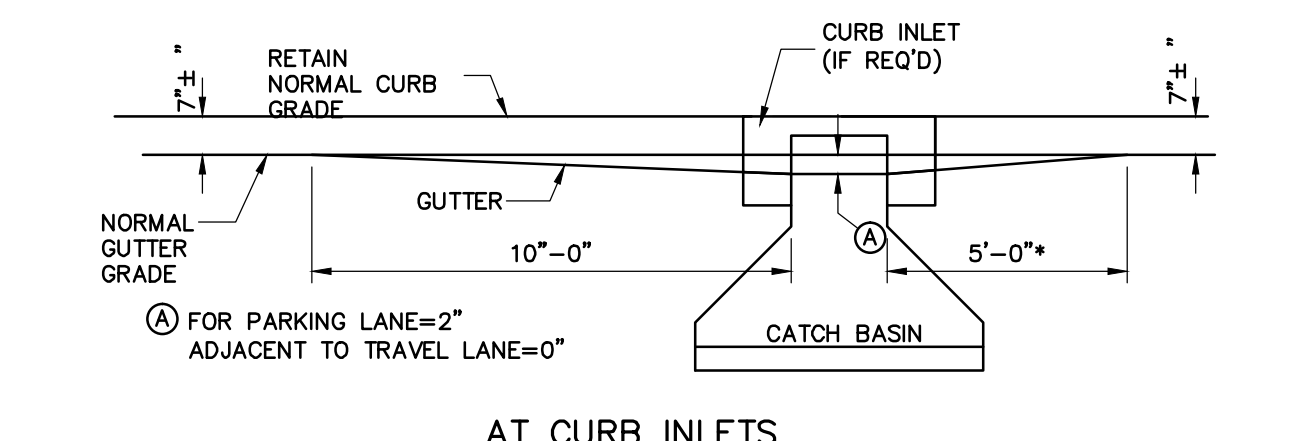

AT CURB INLETS

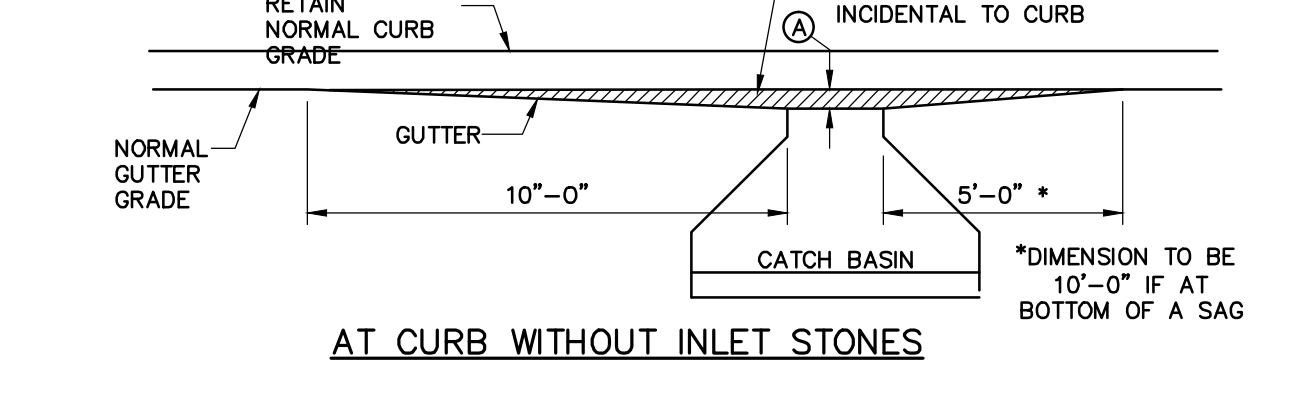

AT CURB WITHOUT INLET STONES

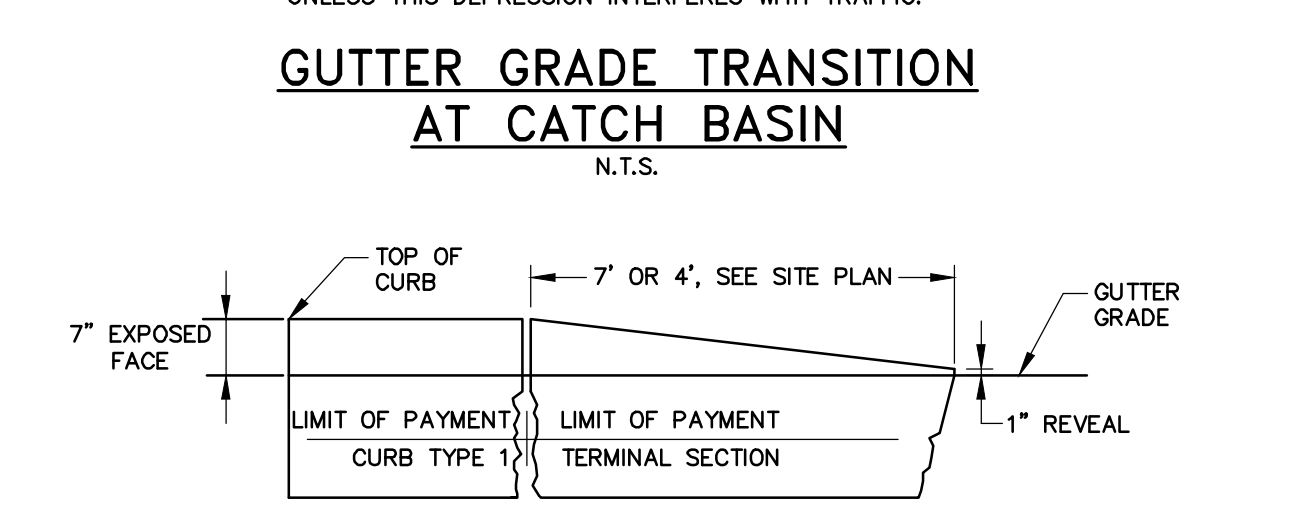

GUTTER GRADE TRANSITION AT CATCH BASIN N.T.S.

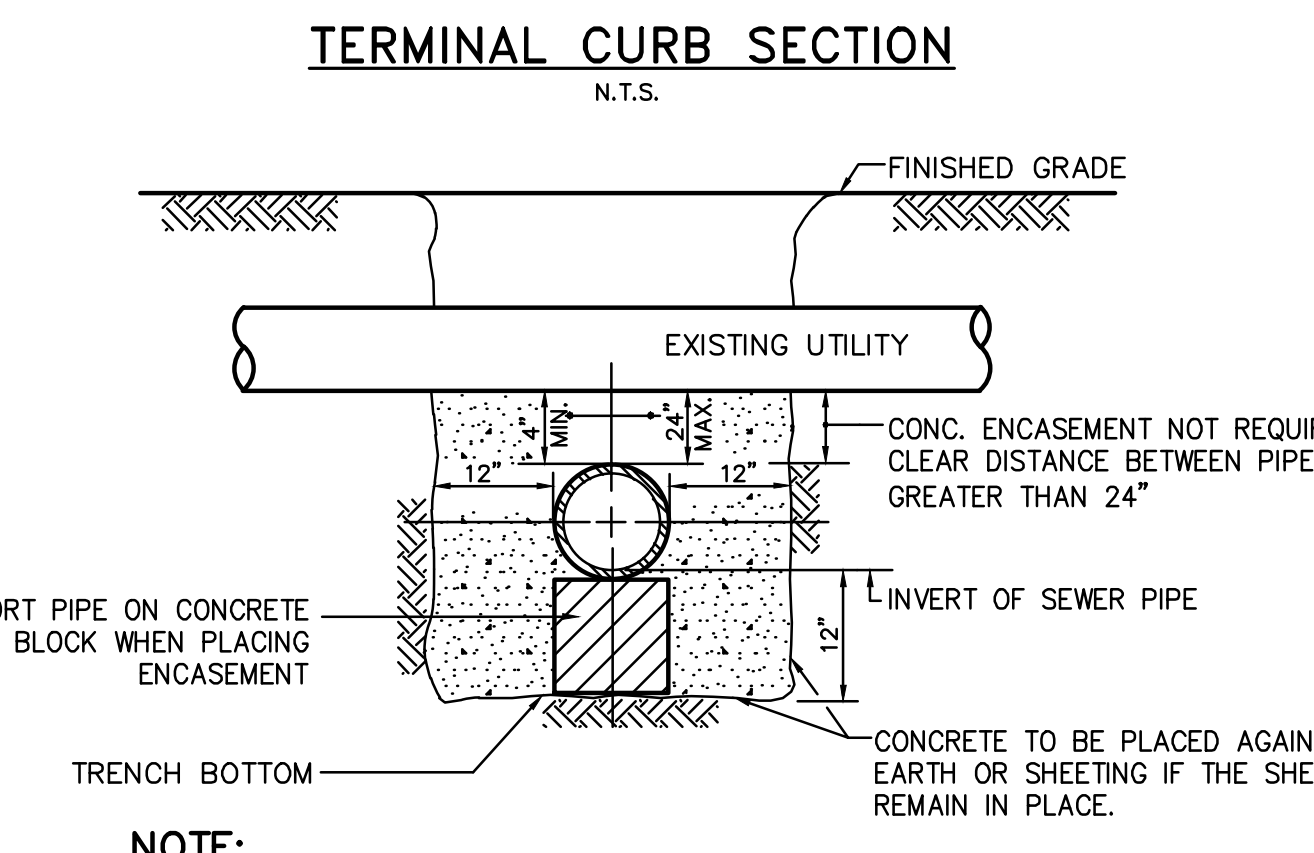

UTILITY CROSSING LESS THAN 24\"/>

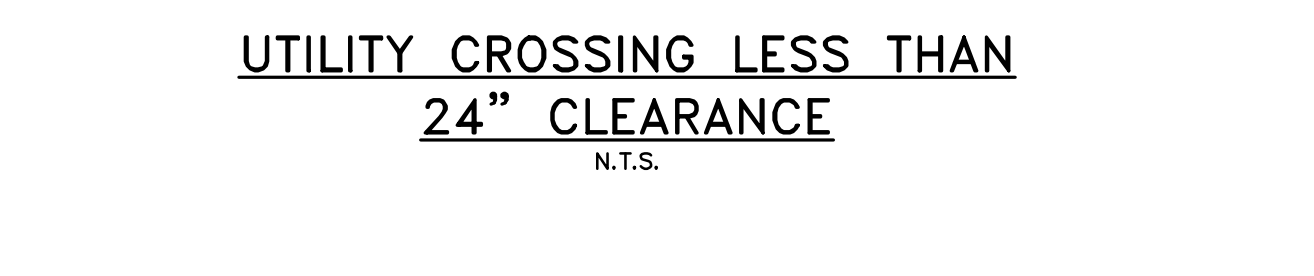

UTILITY CROSSING LESS THAN 24\"/>

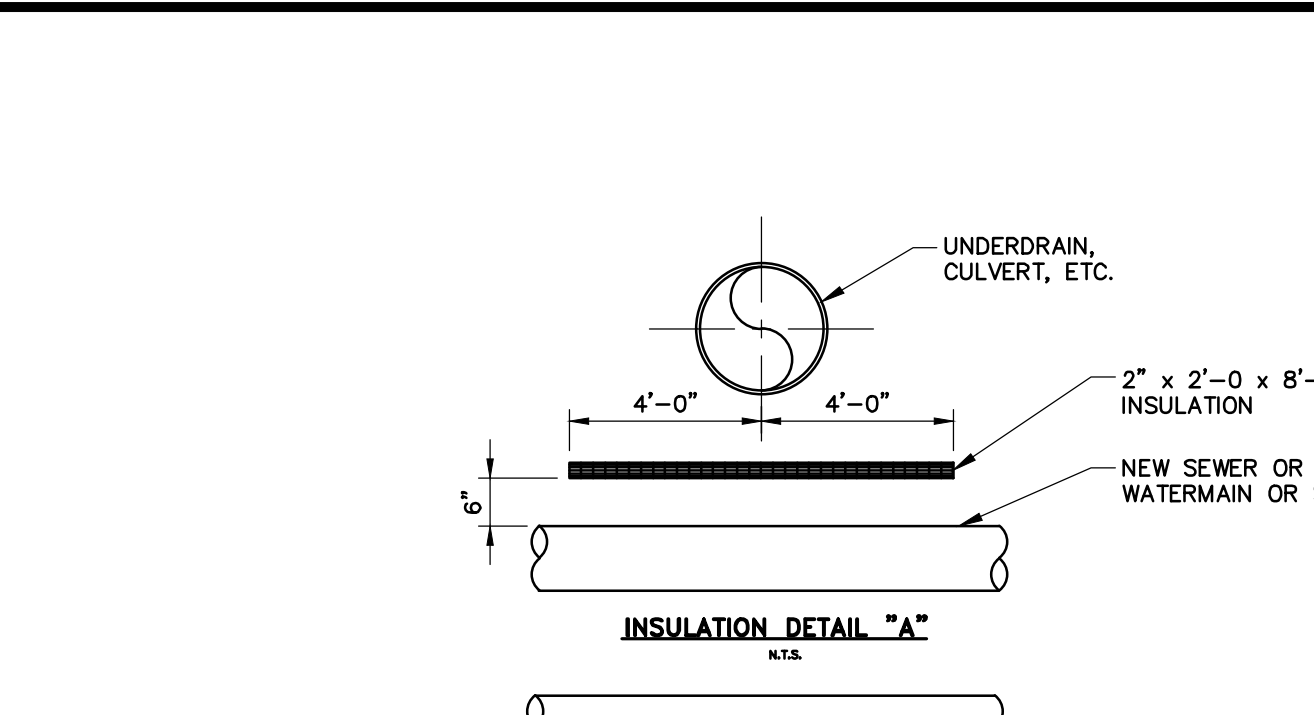

INSULATION DETAIL "A" N.T.S.

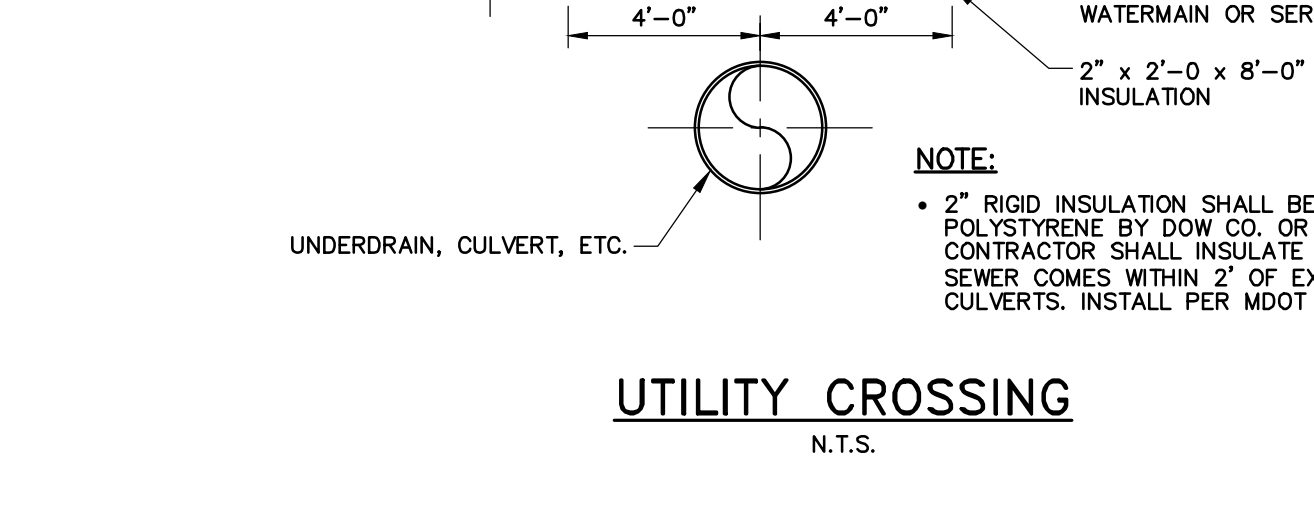

UTILITY CROSSING N.T.S.

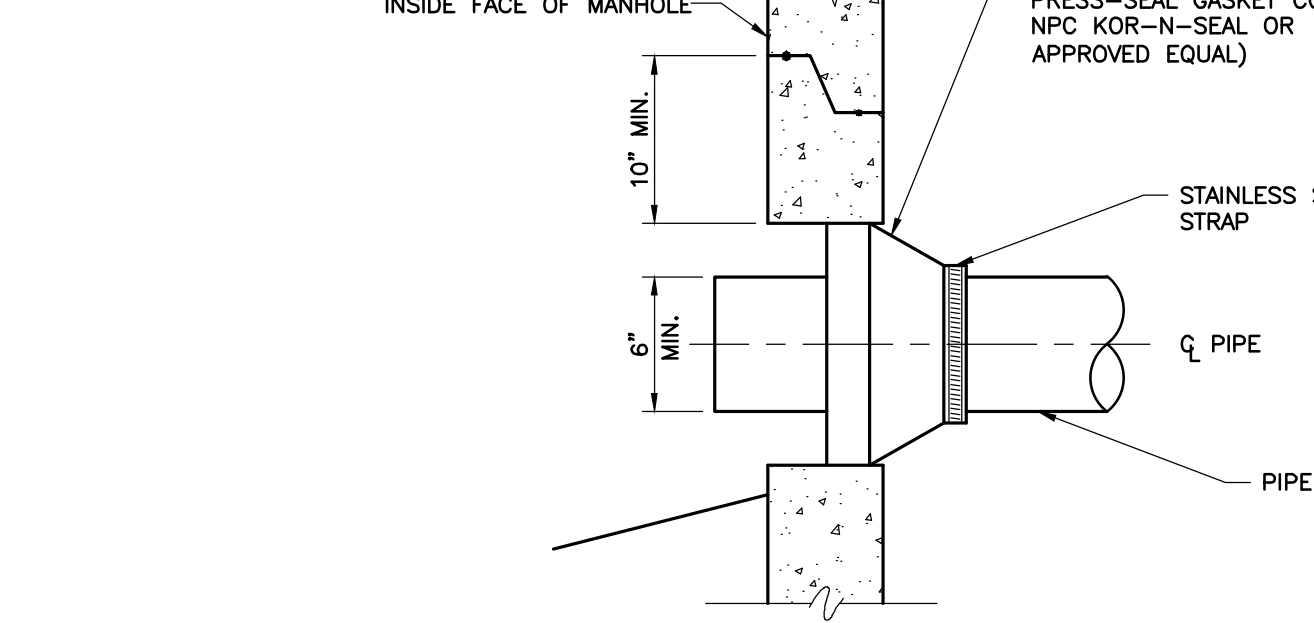

NEW PIPE TO NEW STRUCTURE CONNECTION DETAIL N.T.S.

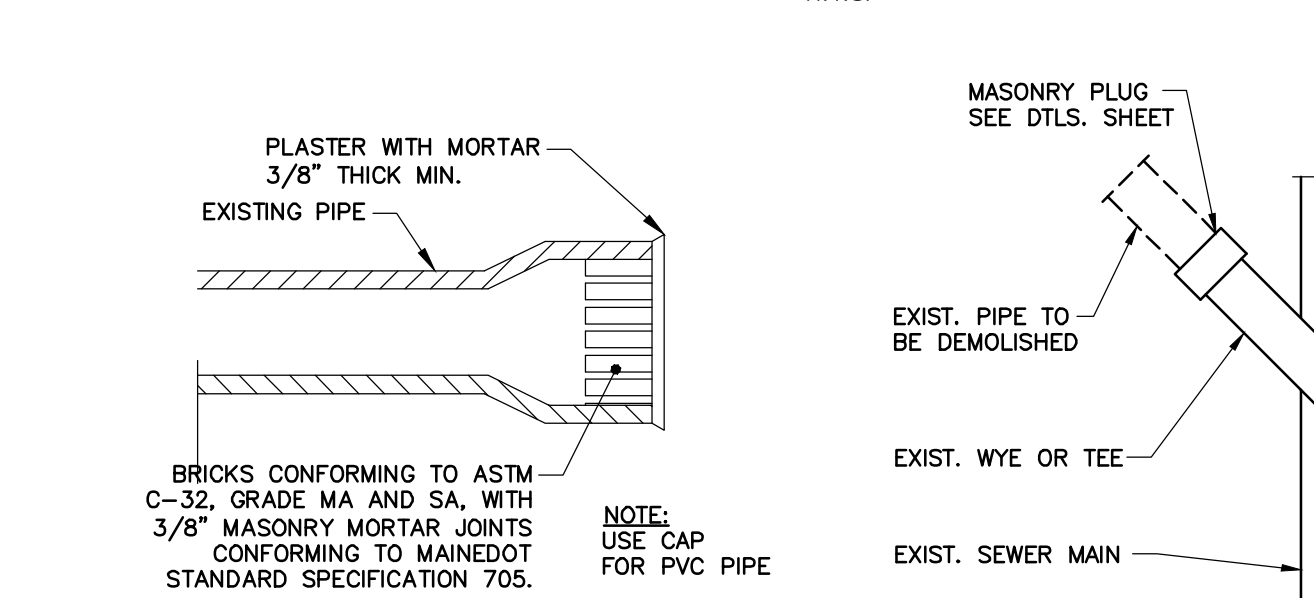

MASONRY PLUG DETAIL N.T.S.

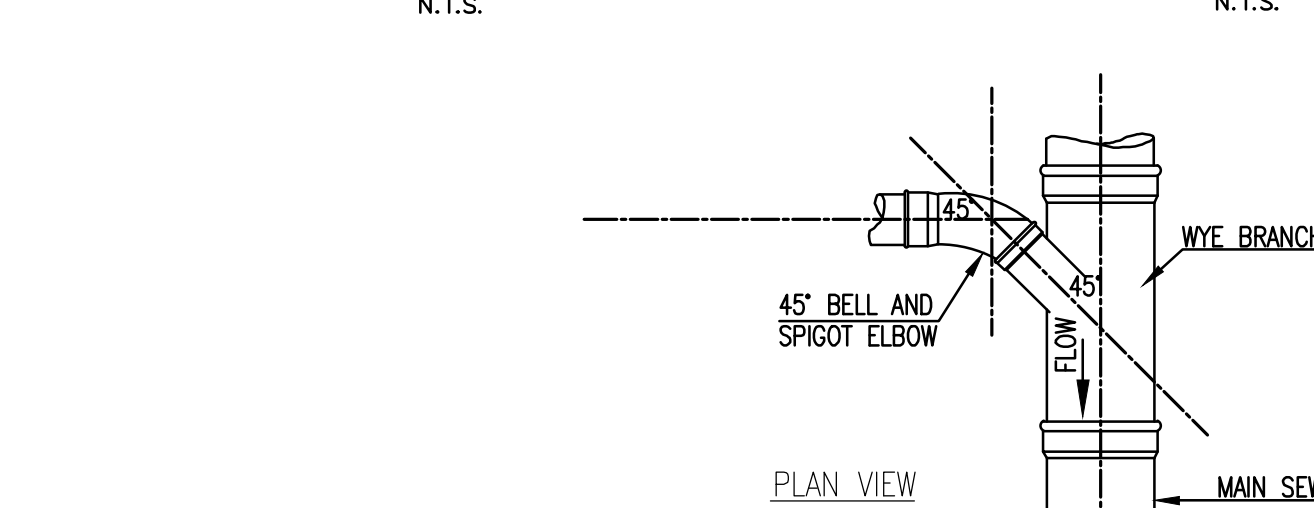

MASONRY PLUG @ MAIN N.T.S.

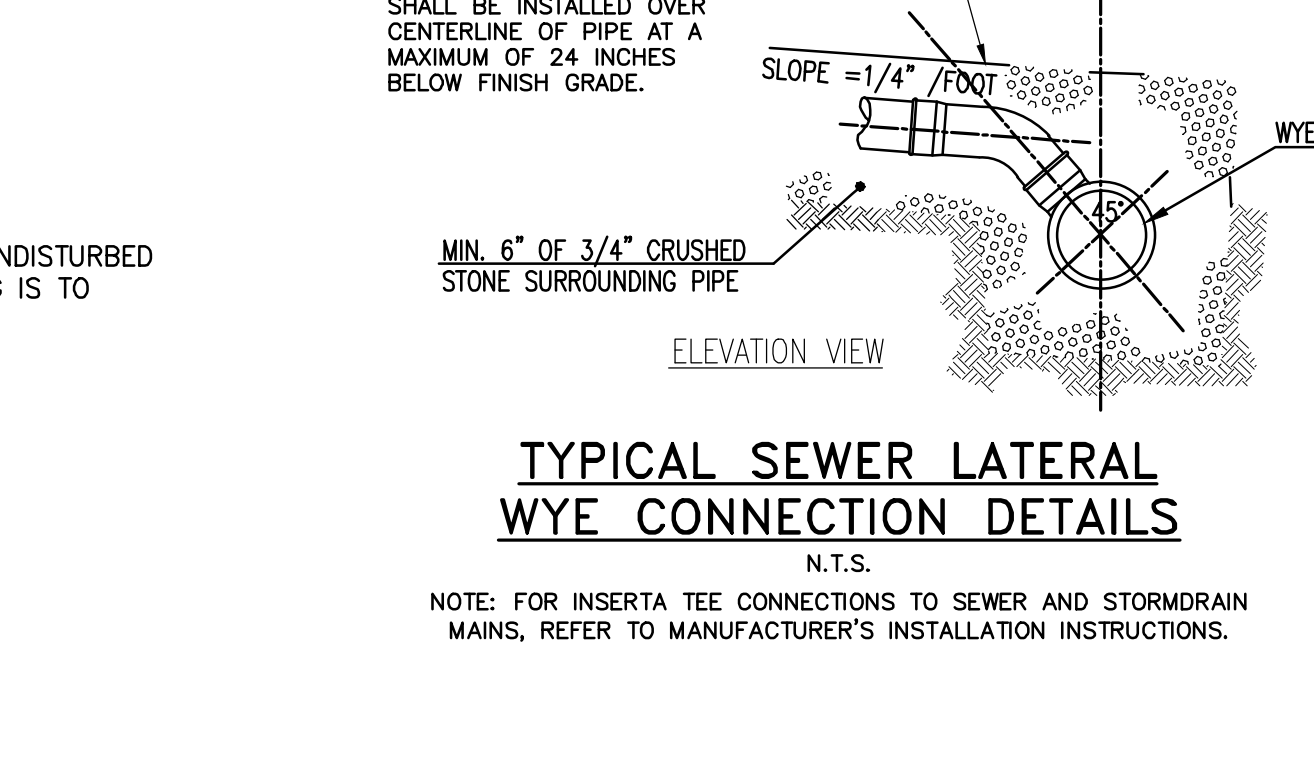

TYPICAL SEWER LATERAL WYE CONNECTION DETAILS N.T.S.

41 Hutchins Drive
Portland, Maine 04102
800.426.4262 | www.woodardcurran.com



ARCHITECTS
49 DARTMOUTH STREET
PORTLAND, MAINE 04101
207-775-1059
www.pdtarch.com

COPYRIGHT 2012
PDT Architects

Reuse or reproduction of the
contents of this document is not
permitted without written
permission of PDT Architects.

AVESTA - Adams School Site Redevelopment
PORTLAND, MAINE

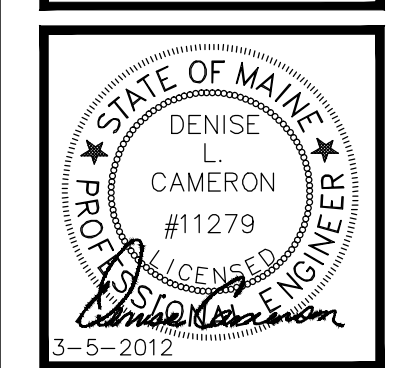

JOB NO.
08-056

DRWN. CHK
BCM DLC

SCALE:
AS NOTED

ISSUE
MARCH 5, 2012

TITLE
CIVIL DETAILS - 2

SHEET

C6