

1 4TH FLR ENLARGED PLAN
SCALE: 1/2" = 1'-0"

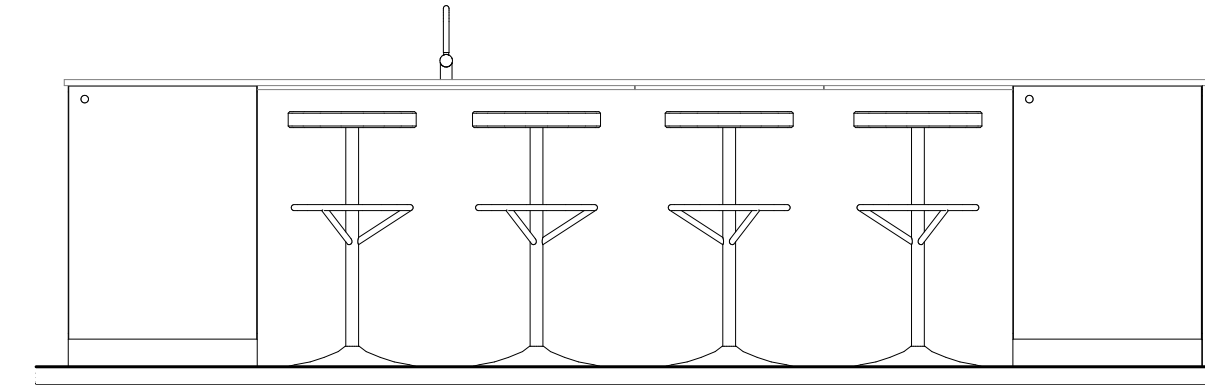

7 ISLAND - BACK SIDE
SCALE: 1/2" = 1'-0"

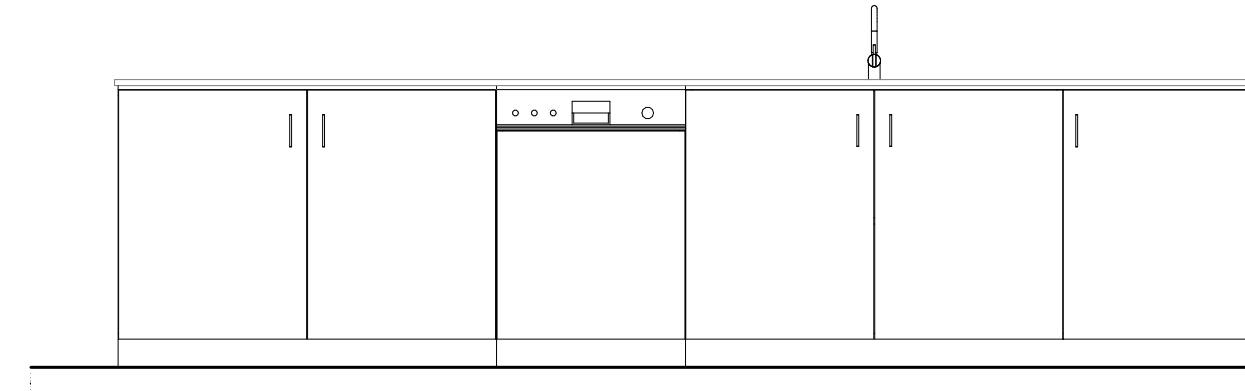

8 ISLAND - RANGE SIDE
SCALE: 1/2" = 1'-0"

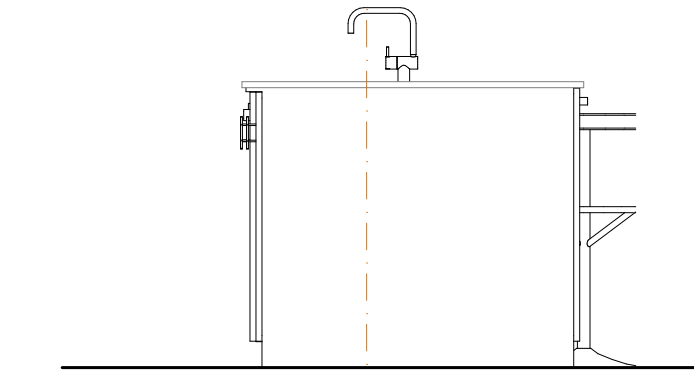

5 ISLAND - LEFT
SCALE: 1/2" = 1'-0"

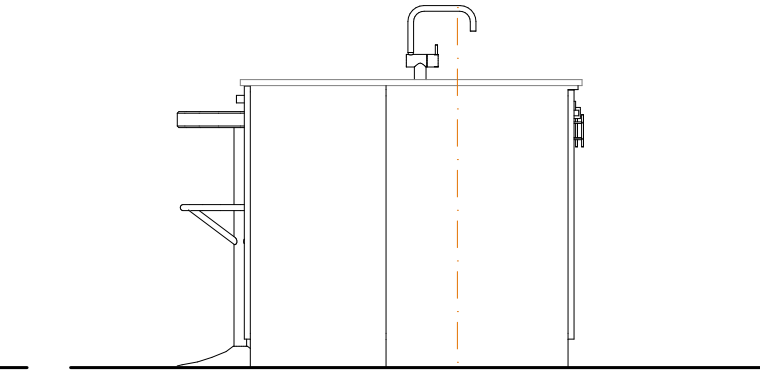

6 ISLAND - RIGHT
SCALE: 1/2" = 1'-0"

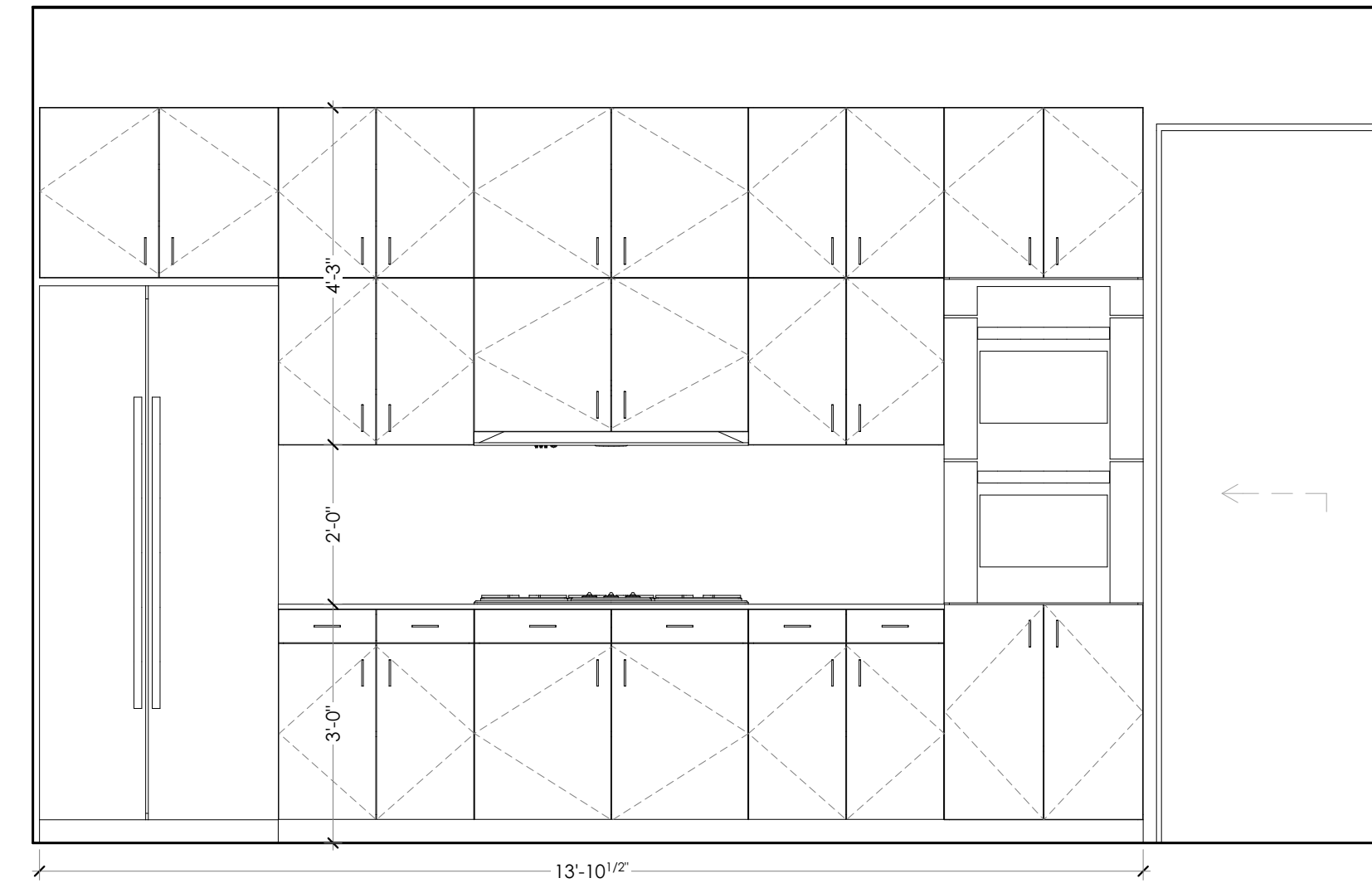

2 OWNER KITCHEN
SCALE: 1/2" = 1'-0"

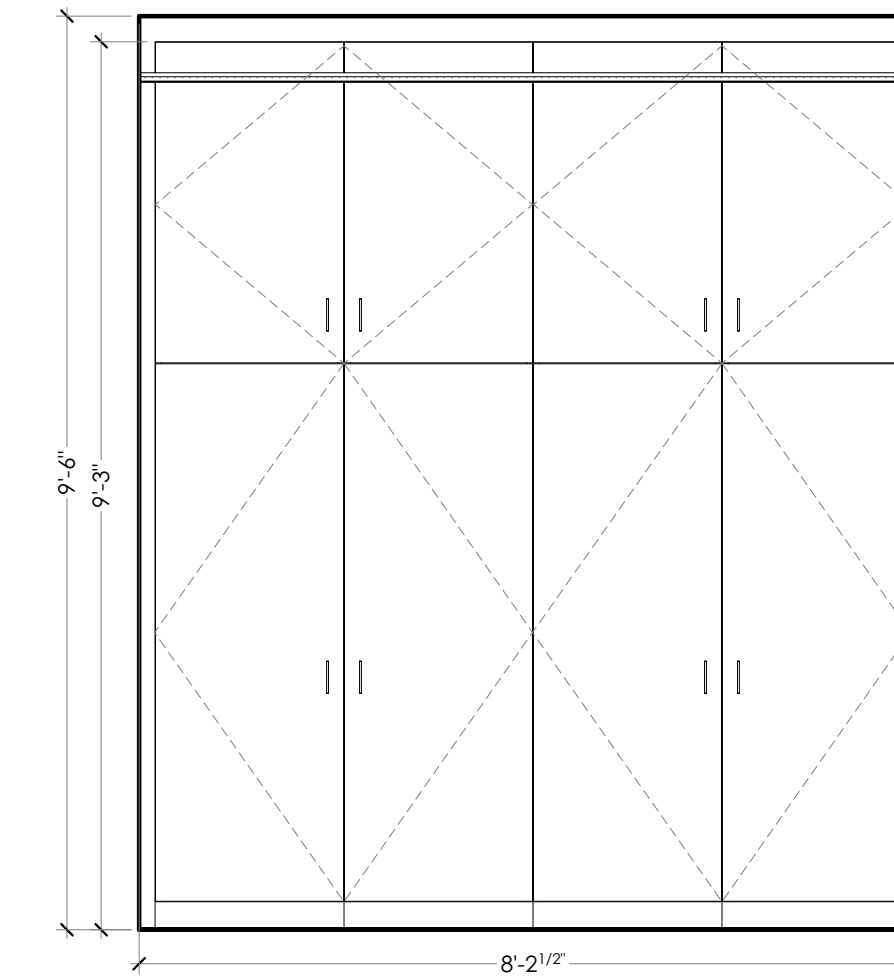

4 OWNER PANTRY - NORTH
SCALE: 1/2" = 1'-0"

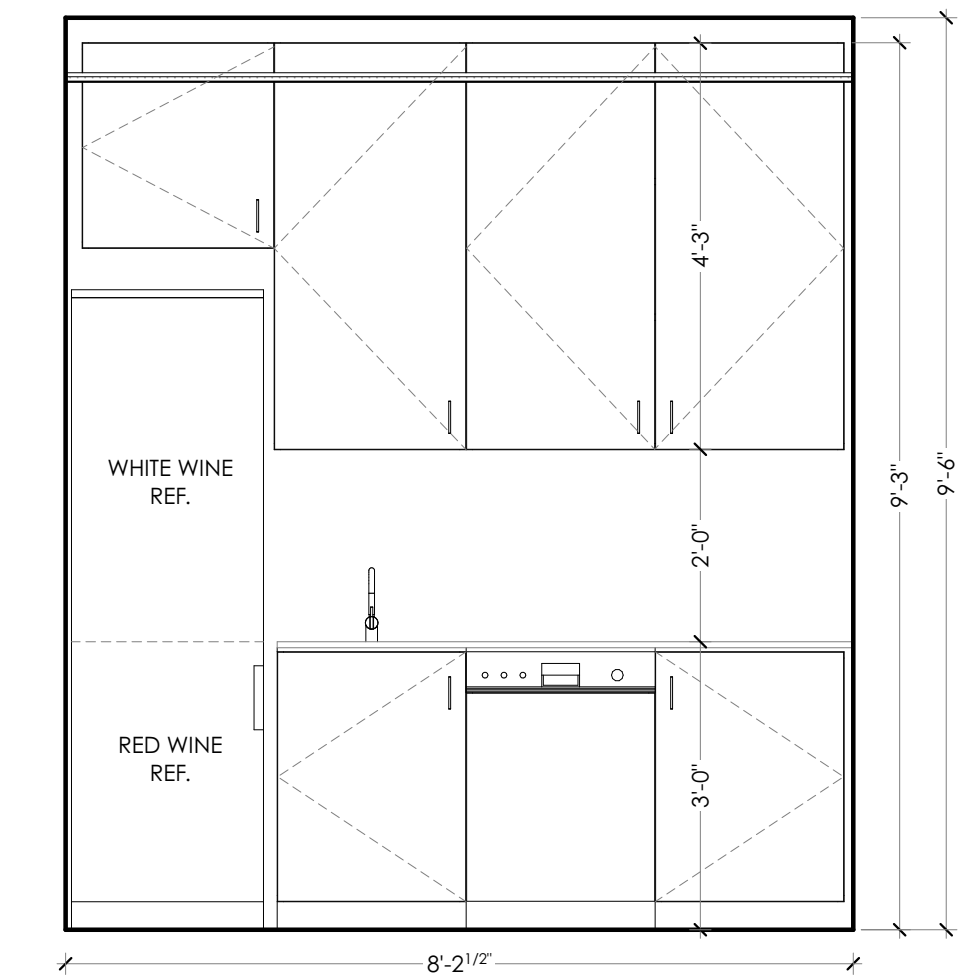

3 OWNER PANTRY - SOUTH
SCALE: 1/2" = 1'-0"

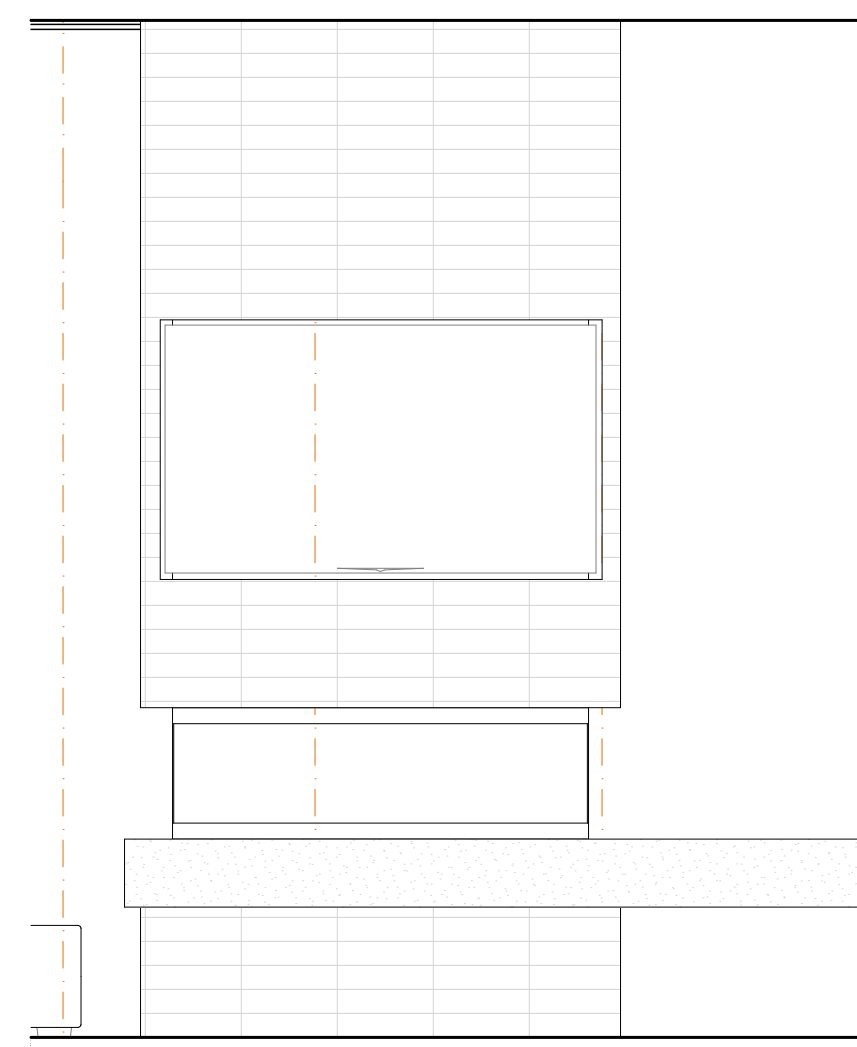

11 FIREPLACE - FRONT
SCALE: 1/2" = 1'-0"

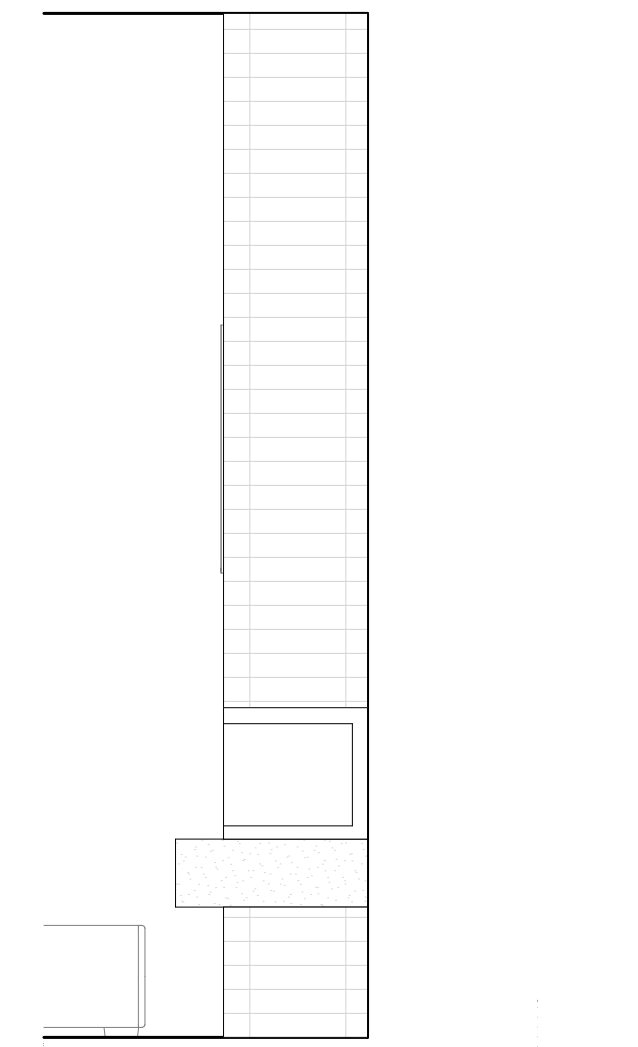

10 FIREPLACE - RIGHT SIDE
SCALE: 1/2" = 1'-0"

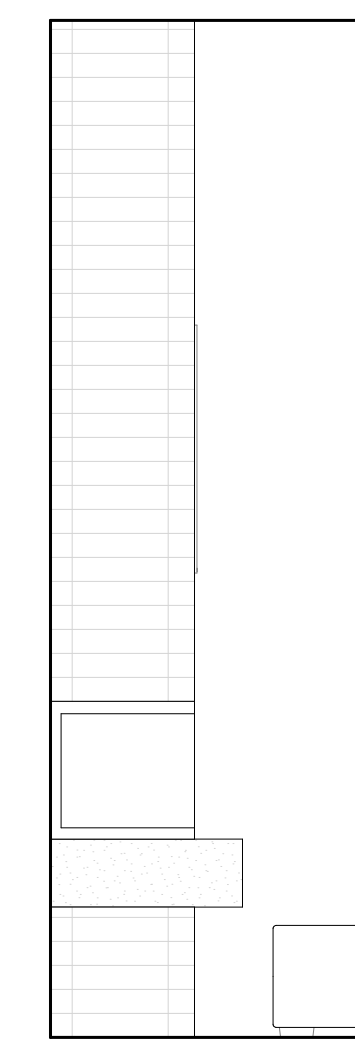

9 FIREPLACE - LEFT SIDE
SCALE: 1/2" = 1'-0"

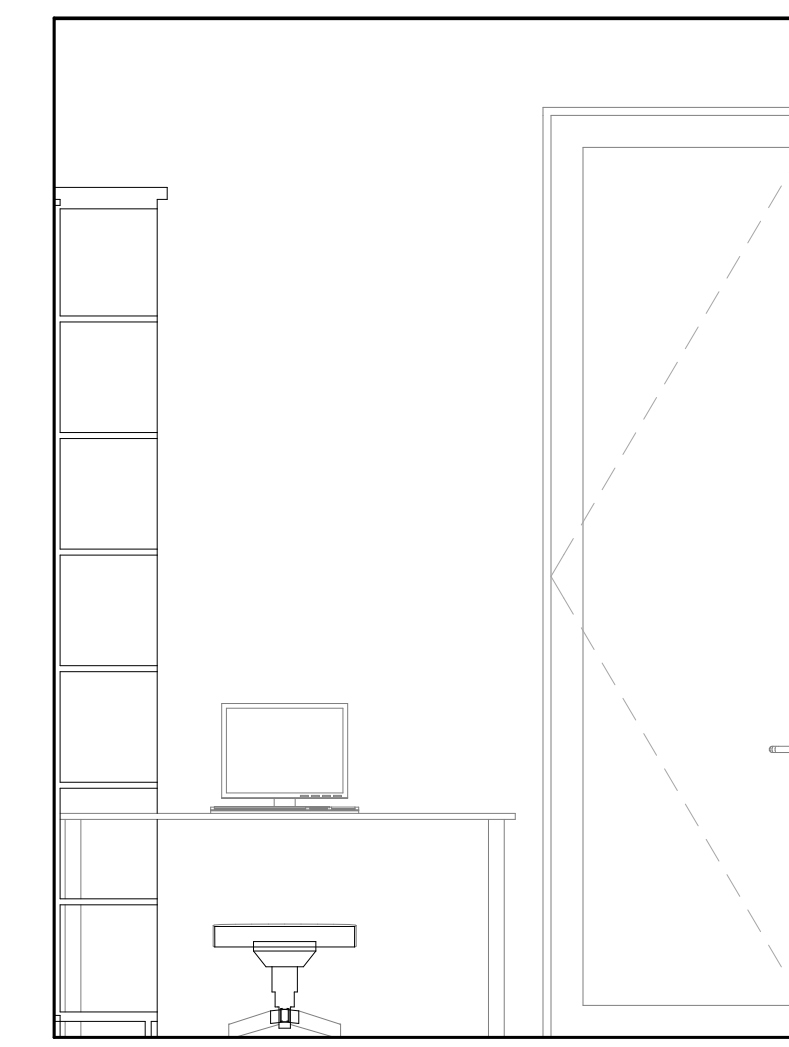

12 OFFICE BUILT-INS - NORTH
SCALE: 1/2" = 1'-0"

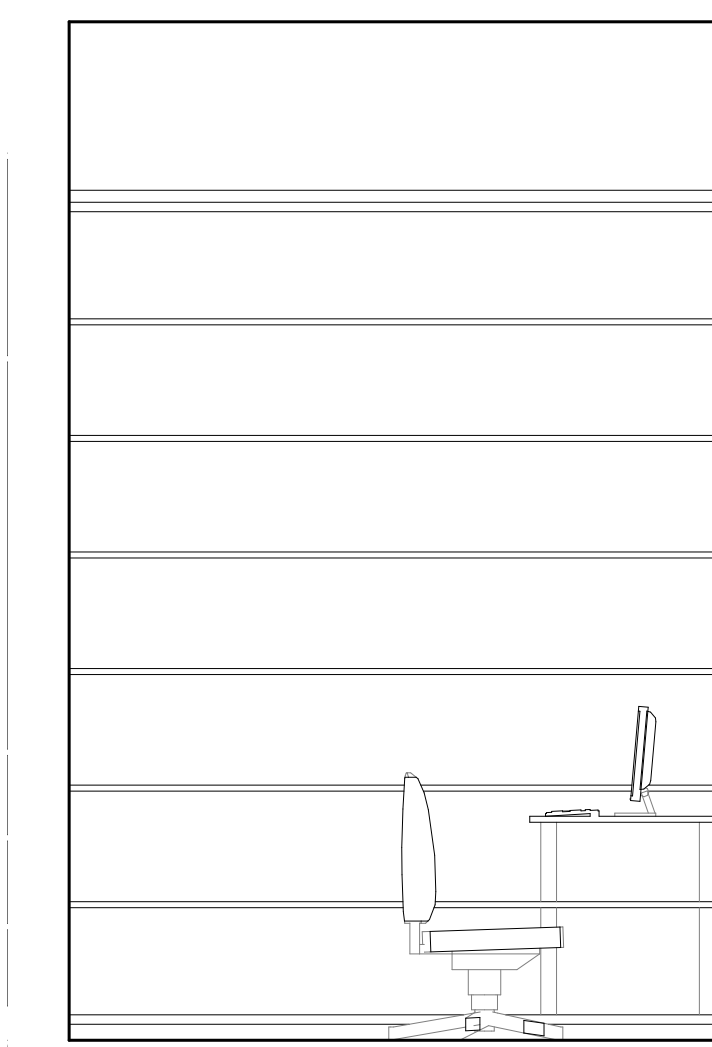

13 OFFICE BUILT-INS - WEST
SCALE: 1/2" = 1'-0"

PRELIMINARY
NOT FOR CONSTRUCTION

INTERIOR ELEVATIONS - OWNER
4TH FLOOR MILLWORK

A-501

Brady Residence

Jim and Julia Brady
9 Moody Street Portland ME 04101

ARCHITECT
DRAFTSPERSON:
PJ/J/OK
PJ/J/OK
3/7/18
PROJECT STATUS:
90% CD'S

CONSULTANT:

SUBMISSIONS:

ISSUE	DATE	DESCRIPTION
001	12/01/2017	CITY REVIEW
002	03/07/2018	REVISOR'S CITY REVIEW COMMENTS

CHANGES THIS ISSUE:

ID	DESCRIPTION