

7 STAIR HANDRAIL SECTION DETAIL  
SCALE: 3" = 1'-0"

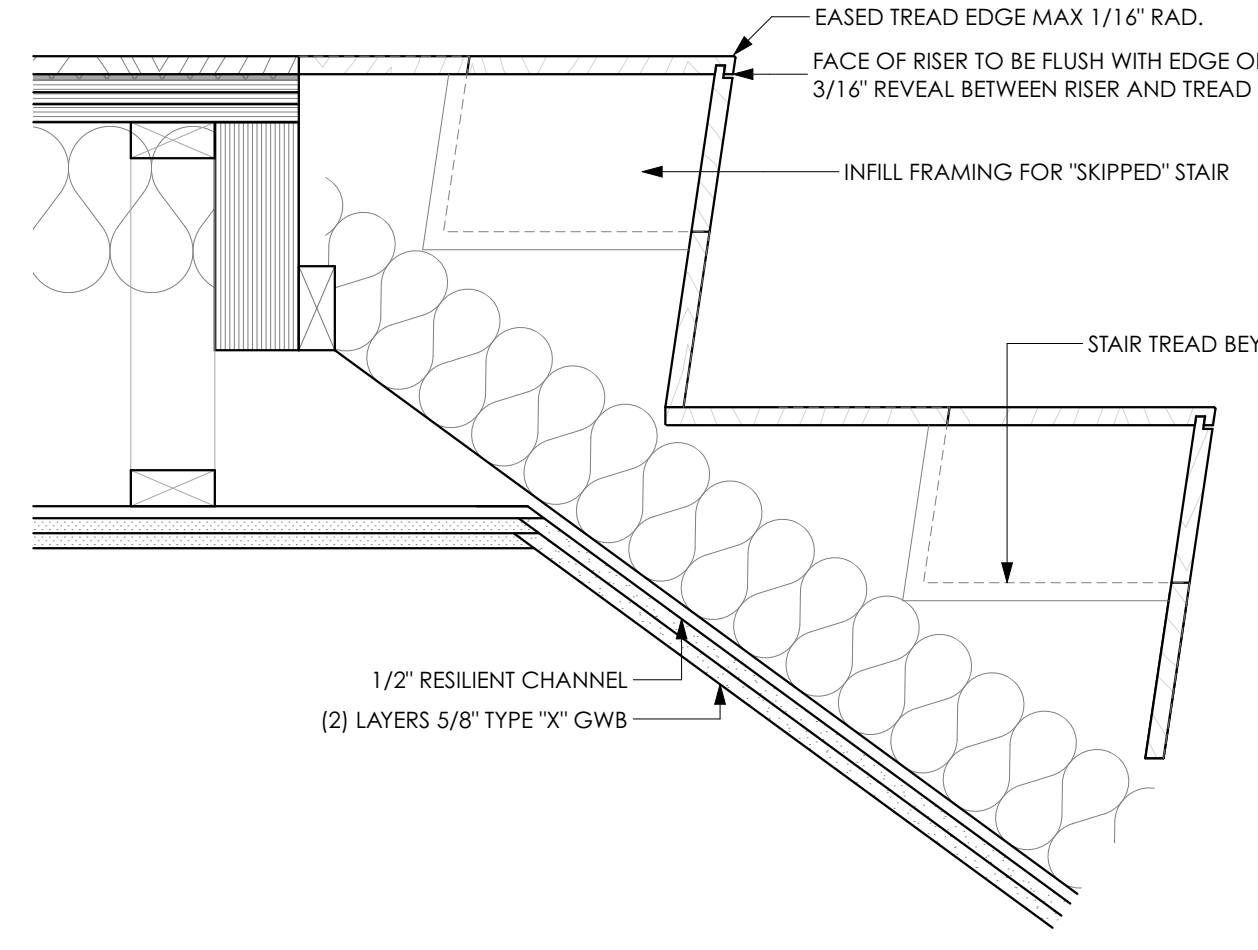

6 STAIR HEAD SECTION DETAIL  
SCALE: 1 1/2" = 1'-0"

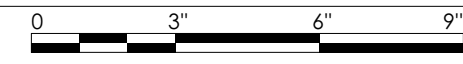
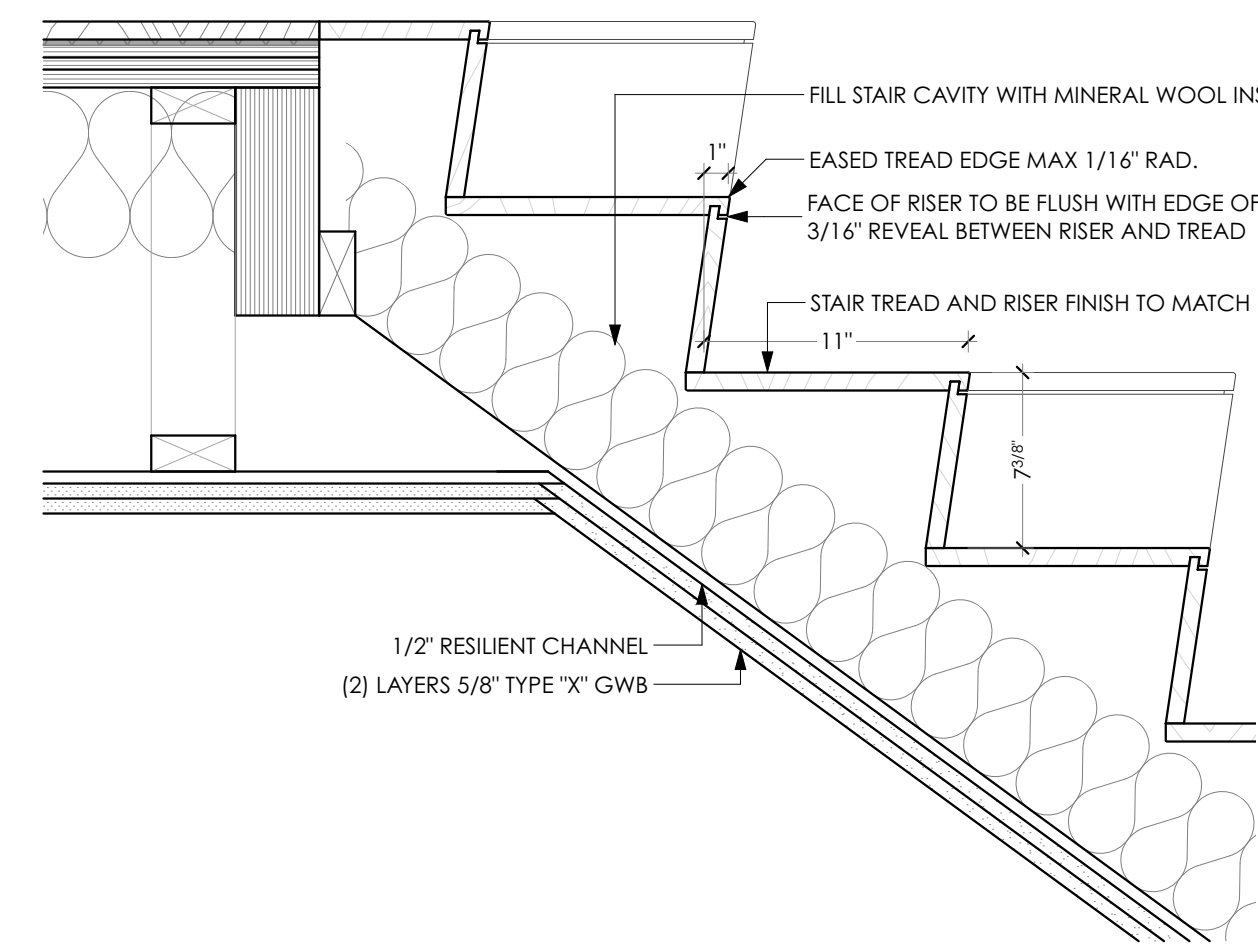
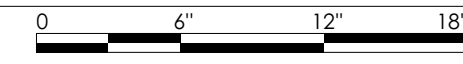

5 STAIR HEAD SECTION DETAIL  
SCALE: 1 1/2" = 1'-0"

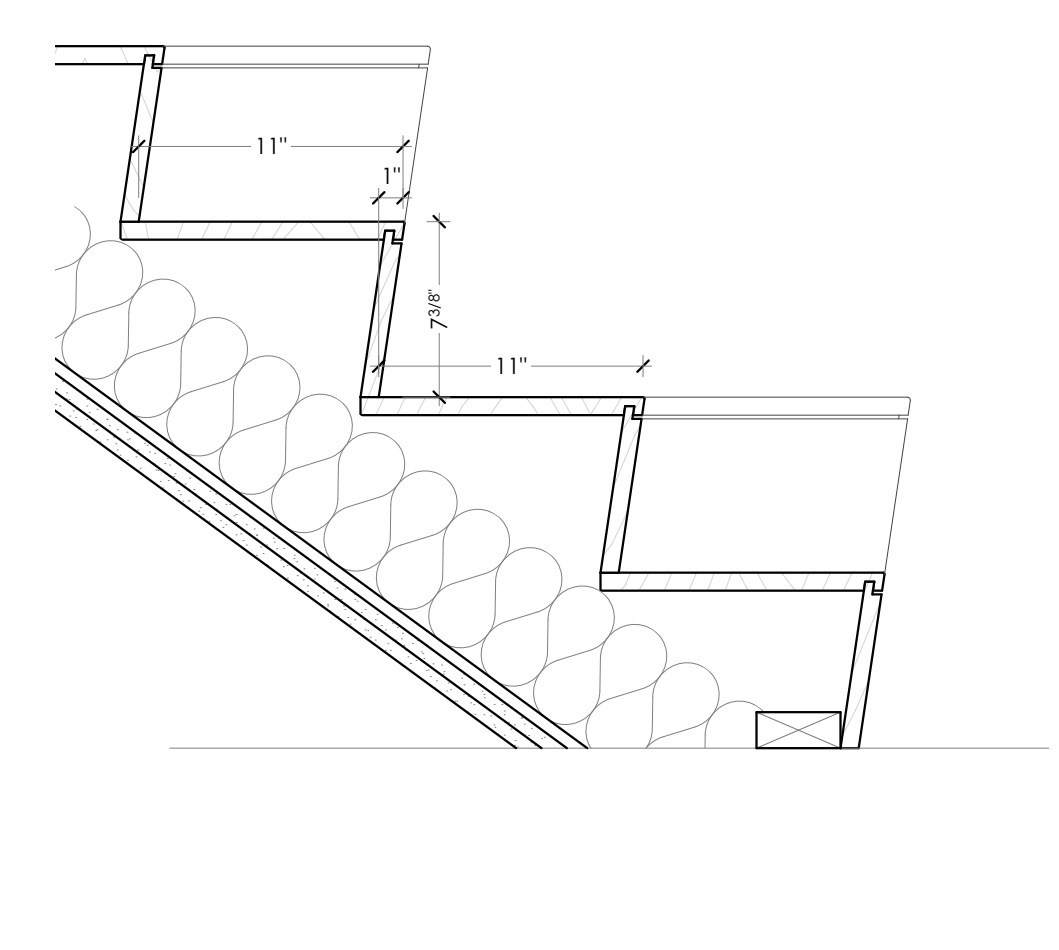
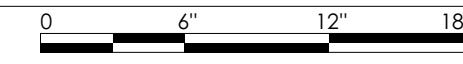

4 STAIR BASE SECTION DETAIL  
SCALE: 1 1/2" = 1'-0"

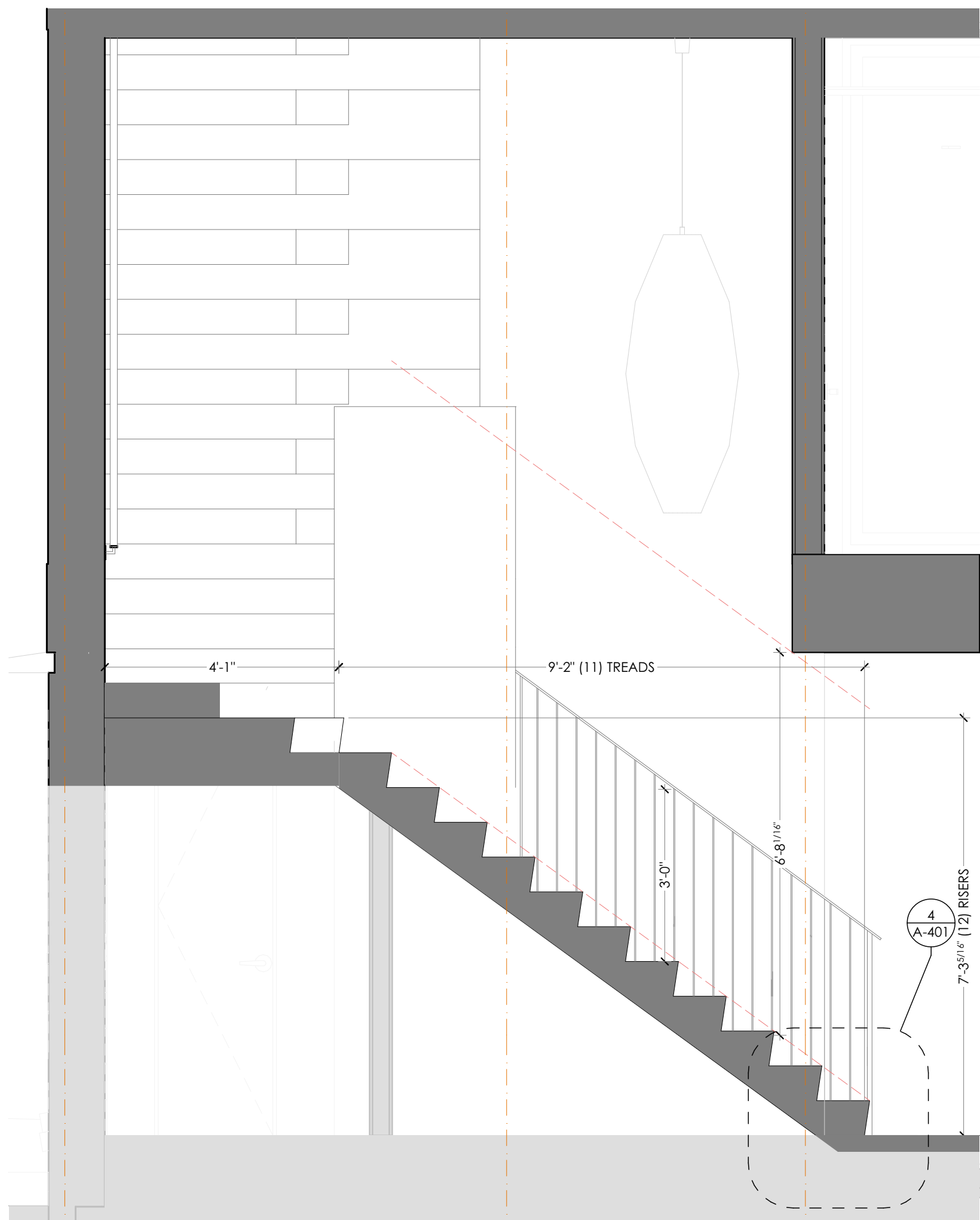
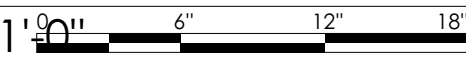

3 OWNER UNIT STAIR SECTION  
SCALE: 1/2" = 1'-0"

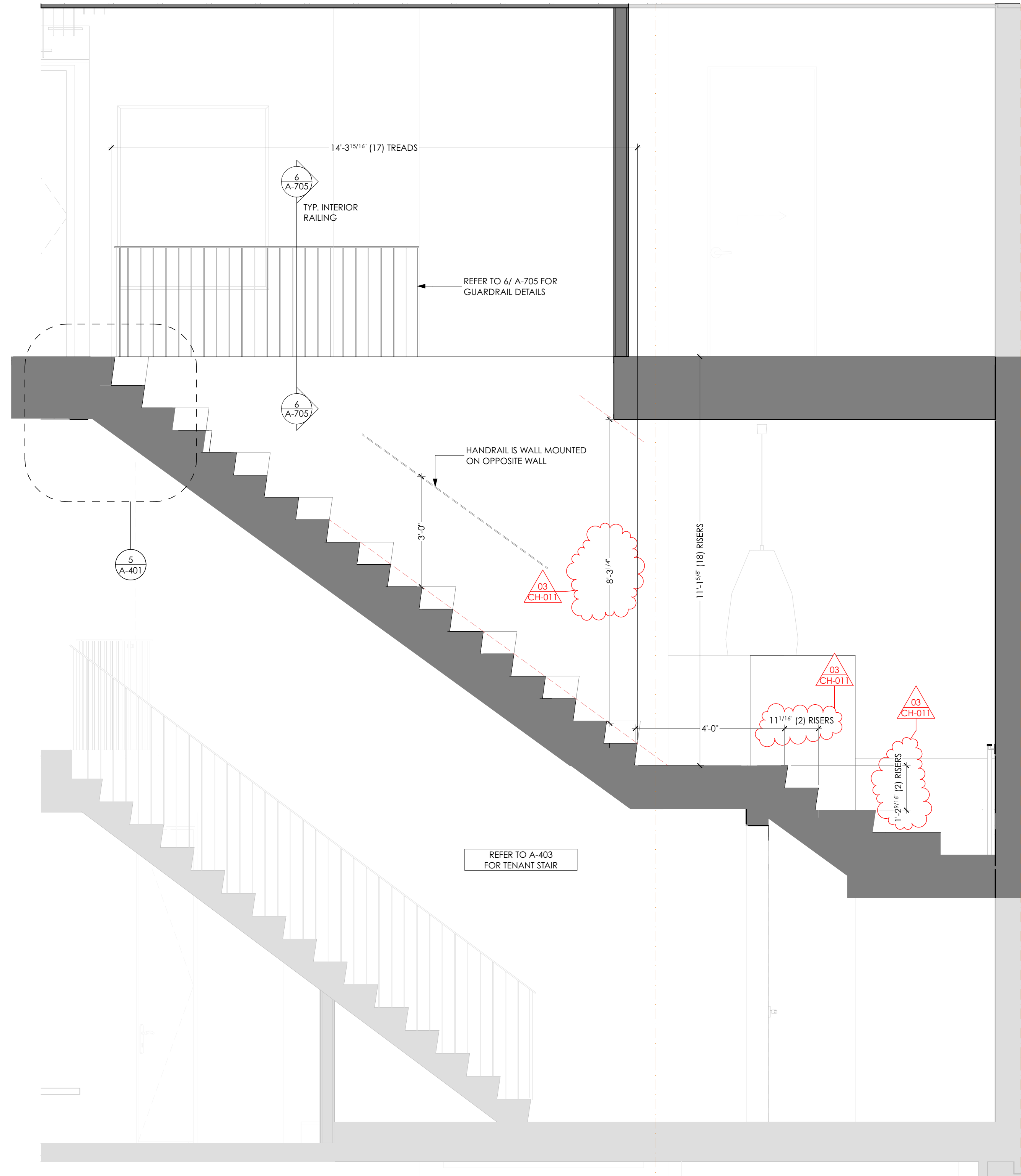
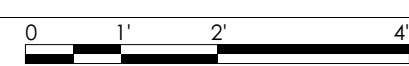

2 OWNER UNIT STAIR SECTION  
SCALE: 1/2" = 1'-0"

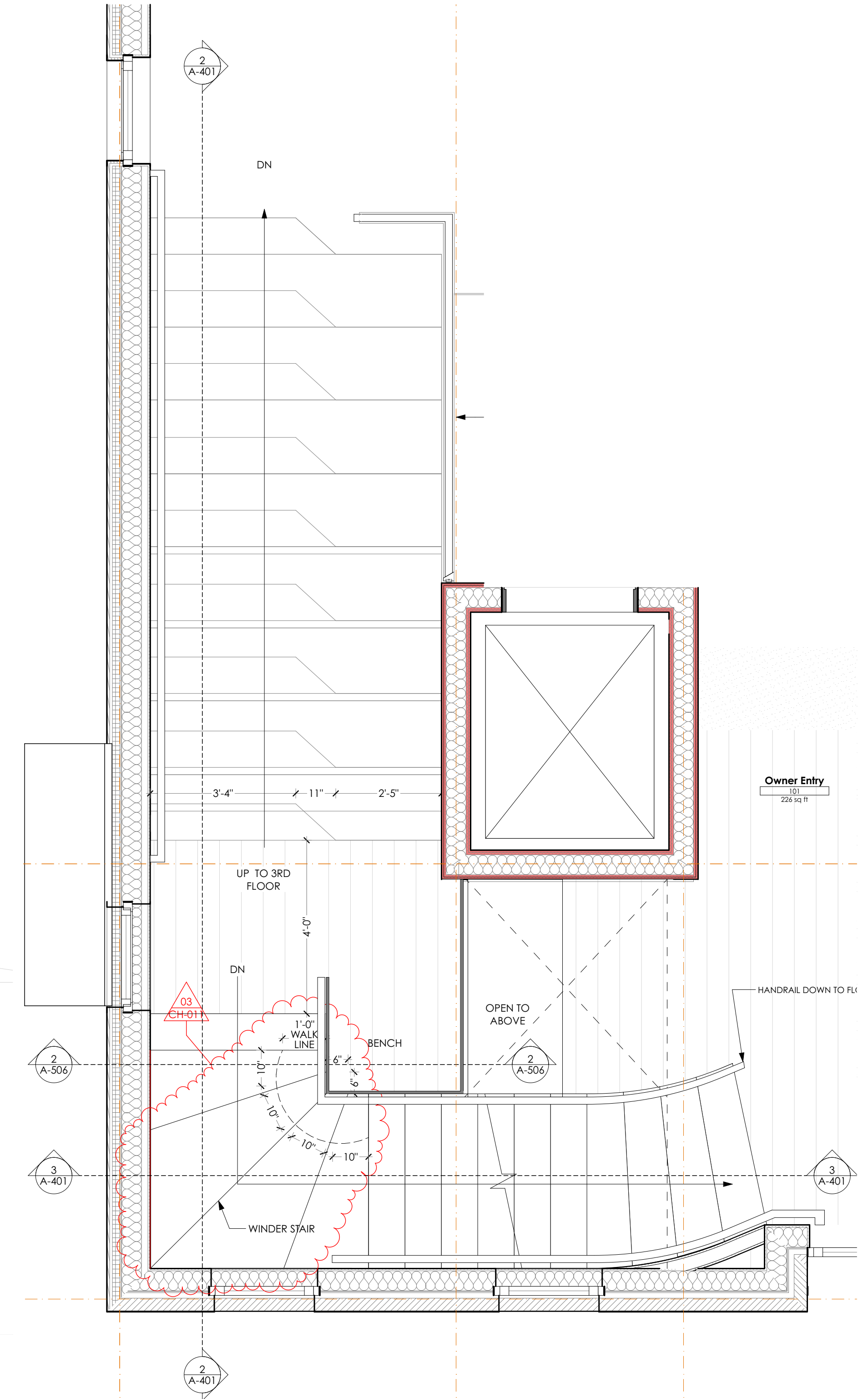
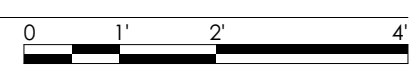

1 OWNER UNIT STAIR PLAN  
SCALE: 1/2" = 1'-0"



CALEB JOHNSON  
STUDIO  
110 EXCHANGE ST. 2ND FLOOR, PORTLAND, ME 04101  
1-207-263-9777

CHANGES THIS ISSUE

ISSUE NUMBER	DESCRIPTION
1	ISSUE CHANGE
2	ISSUE CHANGE
3	ISSUE CHANGE

ISSUE	DATE	DESCRIPTION
1	04/02/2018	City Use Safety Comments #1
2	04/17/2018	City Use Safety Comments #2

FOR CONSTRUCTION

ARCHITECT: DRATSPERSON: P8/JJK/CK  
DATE: 04/11/2018  
PROJECT STATUS: 95% CDS FOR BID

Brady Residence  
Jim and Julia Brady  
9 Moody Street Portland ME 04101

STAIR DETAILS  
A-401