

DESIGNED BY:	LARRY A. WICHROSKI, P.E.
DRAWN BY:	LAW
JOB #:	08114
DATE:	10-26-2015

REVISIONS:	Δ	12-04-2015
	Δ	12-15-2015
	Δ	05-05-2017
	Δ	08-01-2017

STRUCTURAL NOTES:

CODE: Comply with the 2012 International Residential Building Code (IRBC).

DESIGN LOADS: Roof = 16.0 psf, Floor = 12.0 psf.
Dead Loads: Roof = 6.0 psf (Plus Drip), 1st Floor = 40.0 psf, 2nd Floor = 35.0 psf.
Wind Load: Building = 31.0 psf

FOUNDATIONS:

- Bear footings on firm, undisturbed dense native soil at 4"-6" minimum below lowest adjacent finish or natural grade, whichever is lower.
- Place foundation concrete only on clean, firm, dry bearing material.
- Excavation shall be properly braced and shored during excavation.
- Allowable Bearing Capacity = 2,000 psf (Code Max)

CONCRETE:

- Concrete regular weight (144 pcf) with Type II cement per ASTM C150, aggregate per ASTM C33, and potable water. No fly-ash permitted in floor slab. Aggregate size = 1-1/2" maximum for footings and slab. Minimum compressive strength = 3000 psi for foundations and slab on grade and 4,000 psi for exterior slabs and sidewalks.
- Wet cure concrete for 5 days or with a curing compound approved by the Engineer.
- Saw cuts for floor slab control joints shall be made as soon as the slab can support the weight of the saw, but no more than 12 hours after placing concrete.
- Provide isolation joints using 2" thick formed pre-molded joint filler where slab on grade abuts all vertical structural members.
- Shop foundation, interior slab and exterior slab concrete mix designs for engineer's review.
- Non shrink grout shall be rammed in tight to maximum density attainable with a minimum 28 day strength of 5,000 psi.

NON-SHRINK GROUT:

- Provide L & M non-shrink, flowable structural grout (Diaground) or approved equal.
- Grout shall be placed in accordance with manufacturer's recommendations.
- Placement shall be in accordance with manufacturer recommendations.

REINFORCING:

- ASTM A 615-S1, Grade 60 except as follows:
 - #2 and #3 bars ASTM A615-S1, Grade 40.
 - Field Bars and Welded Bars, ASTM A 706.
- Reinforcing bars deformed except #2 bars and welded plain wire fabric.
- Concrete coverage for reinforcing bars (to face of bar including ties) except as shown or noted:
 - Unformed concrete in contact with earth: 3"
 - Formed concrete in contact with earth: 2"
 - Lap splices in concrete: 42 bar diameter.
 - Mesh spacing: 4"
- Provide bent corner reinforcing to match and lap with horizontal reinforcing at corners and intersections of walls, and footings per A.C.I. Detailing Manual (ACI 315).
- Dowel all vertical reinforcing to footings.

STEEL:

- Steel sections and plates: ASTM A-36, Fy = 26 ksi.
- Steel Pipe Column: (not fully columns) ASTM A-36, Fy = 36 ksi.
- Bolts and plain anchors: ASTM A 307.

WOOD:

- General:
 - Each piece of lumber shall be "S.D.B.Y." and bear the grade stamp of a grading rules agency approved by the Maine Department of Inland Fisheries and Wildlife.
 - Double up studs at jambs and under beams.
 - Do not notch or drill joists, beams or load bearing studs without approval.
- Connections:
 - Nail roof plywood with 8d common at 6" o.c. at all edges and boundary members and 10" o.c. at intermediate supports.
 - Use 16d common nails with 16d common nails at 6" o.c. at all edges and boundary members and 12" o.c. at intermediate supports.
- Structural Sawn Lumber:
 - 2 x 6 thru 2 x 14 joists: Spunue Pine Fir No. 1 with Fb (repetitive) = 1200 p.s.i.
 - Studs: Spunue Pine Fir No. 1 with Fb (repetitive) = 1200 p.s.i.
 - Laminated Veneer Lumber (LVL): Fb = 2900 psi, Fv = 285 psi, E = 2,900,000 ksi.

SUPPLEMENTARY NOTES:

- Verify all dimensions and conditions with architectural drawings prior to starting work. Notify the Engineer of any discrepancies or inconsistencies.
- Provide all necessary temporary bracing, shoring, guying or other means to avoid excessive stresses and to hold structural elements in place during construction.

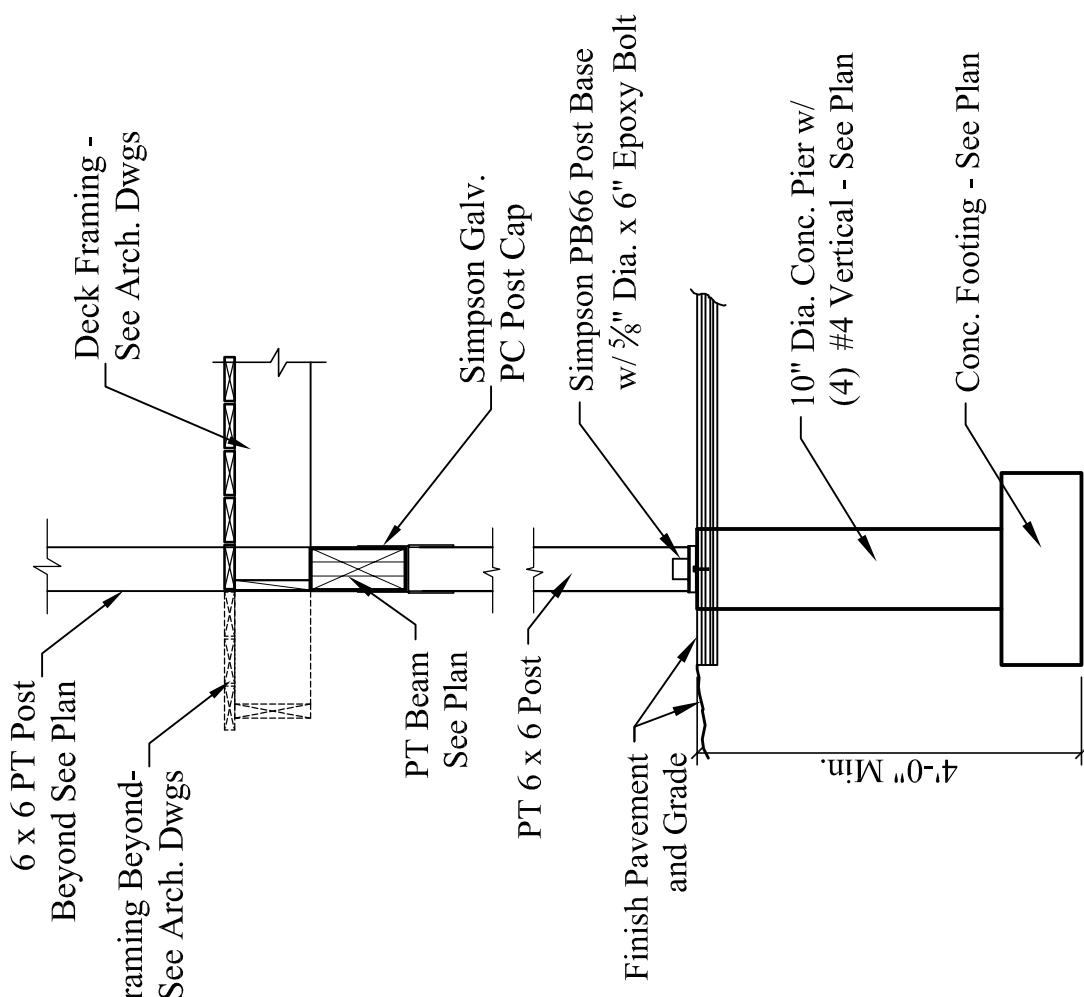

3 POST CONN. @ CONC. PIER
Scale: 1/2" = 1'-0"

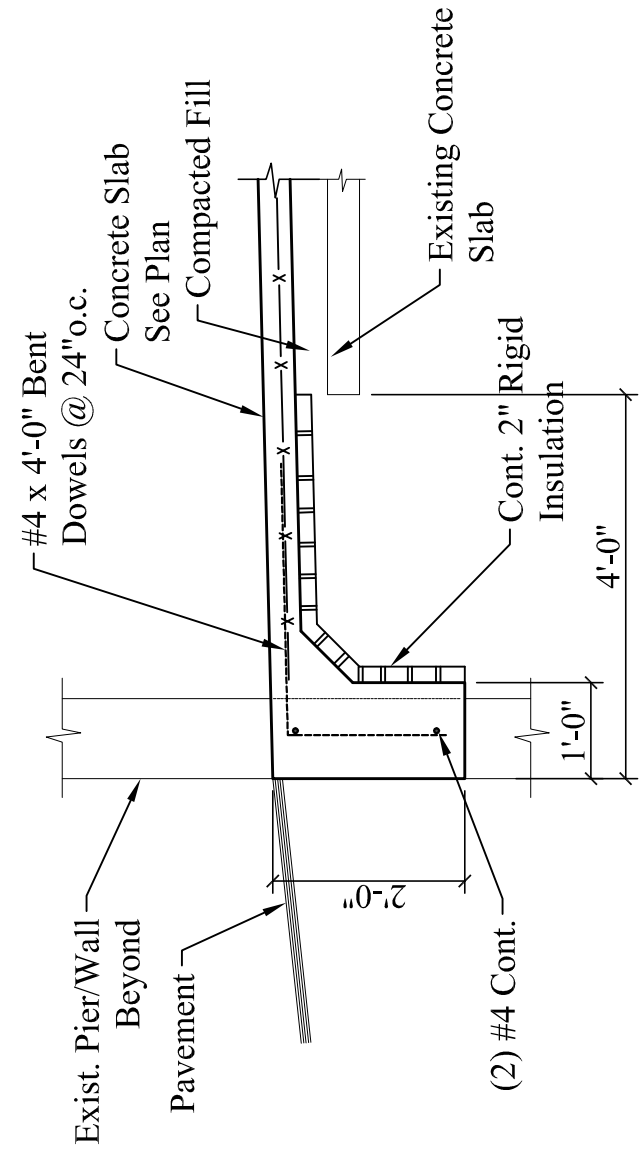

6 SLAB TURNDOWN @ DOOR
Scale: 1/2" = 1'-0"

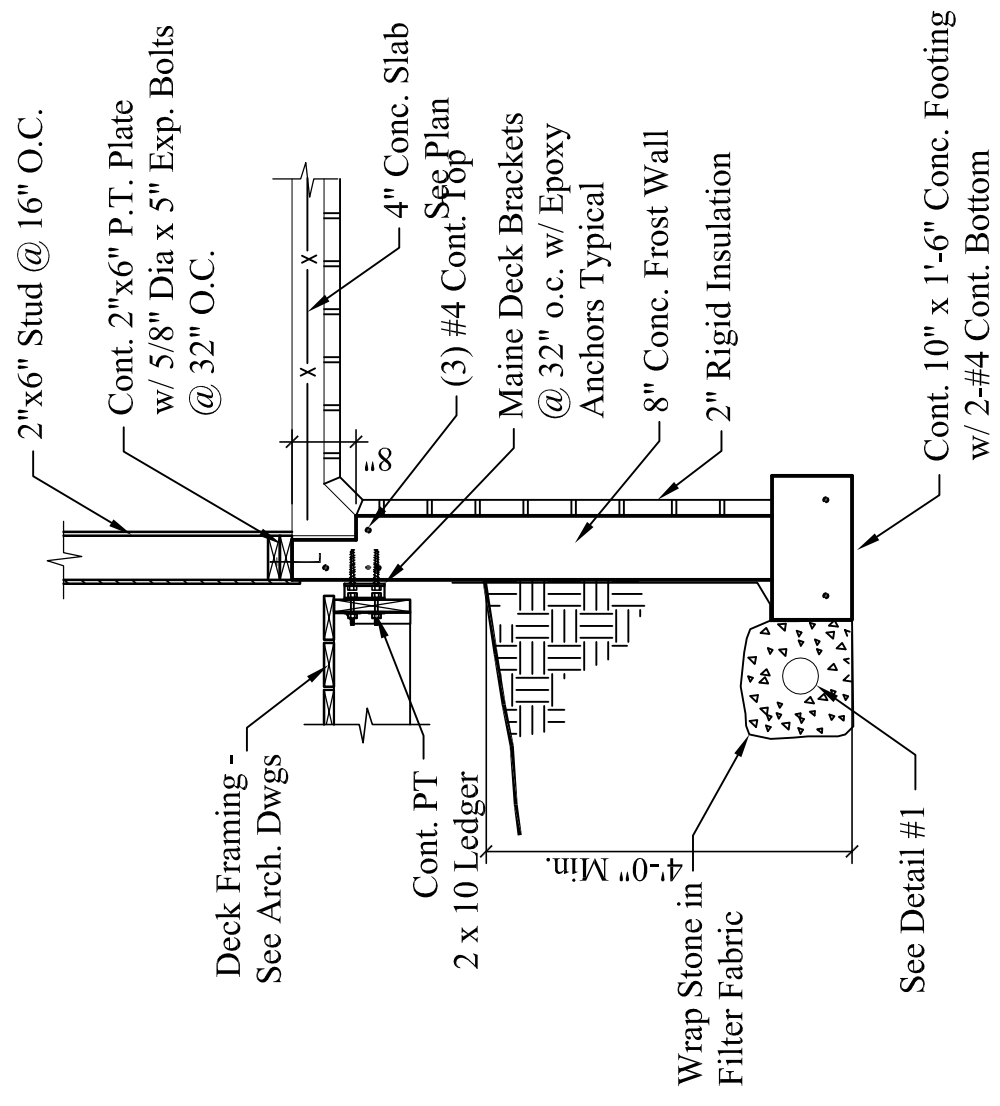

NOTE: See Detail #1 for info. not shown.

2 FOUNDATION @ DECK
Scale: 1/2" = 1'-0"

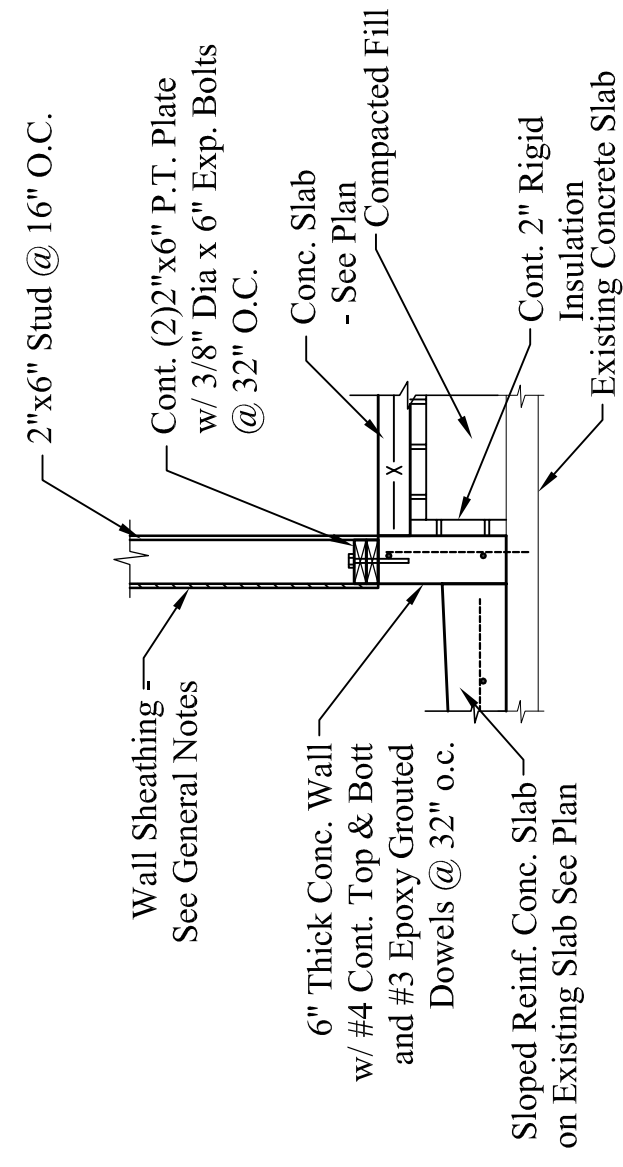

5 RAISED FLOOR @ GARAGE
Scale: 1/2" = 1'-0"

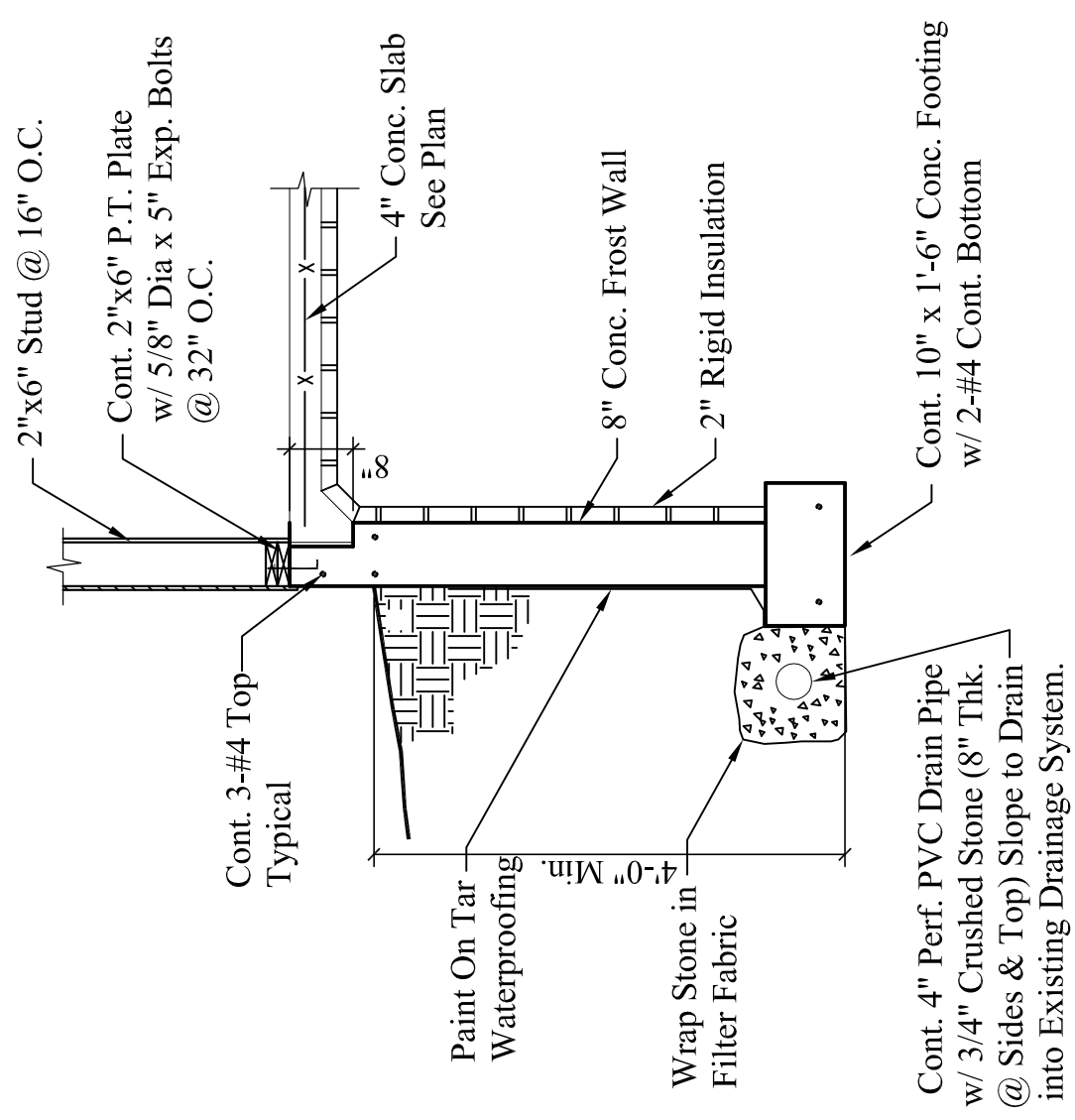

1 FOUNDATION @ STUD WALL
Scale: 1/2" = 1'-0"

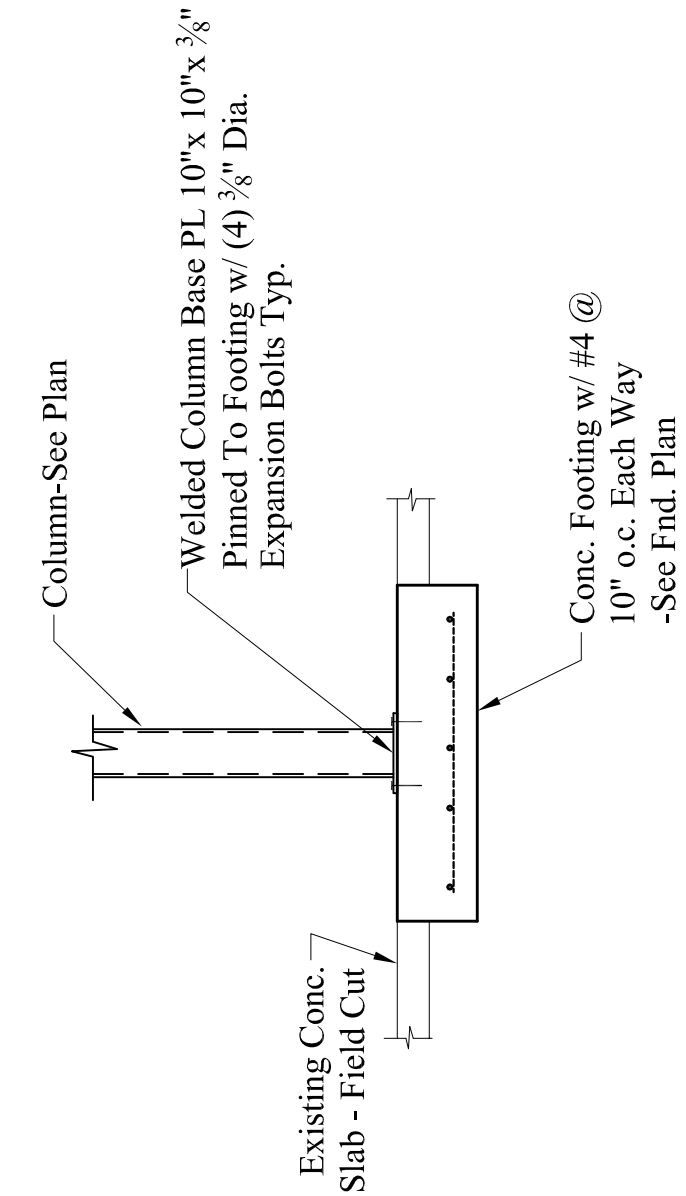

4 INTERIOR COLUMN FOOTING
Scale: 1/2" = 1'-0"

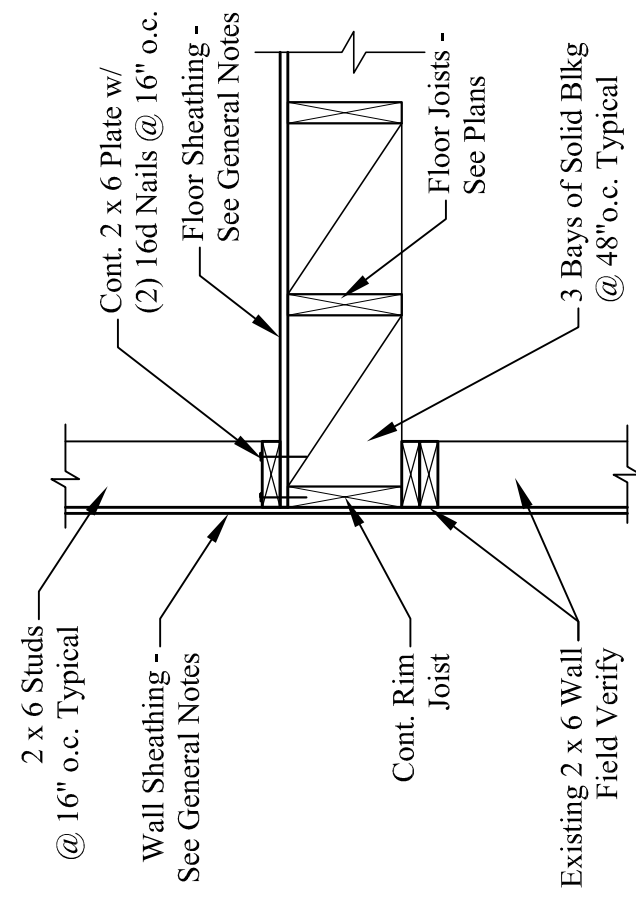

8 FLOOR JOIST @ NON-BRG. WALL
Scale: 3/4" = 1'-0"

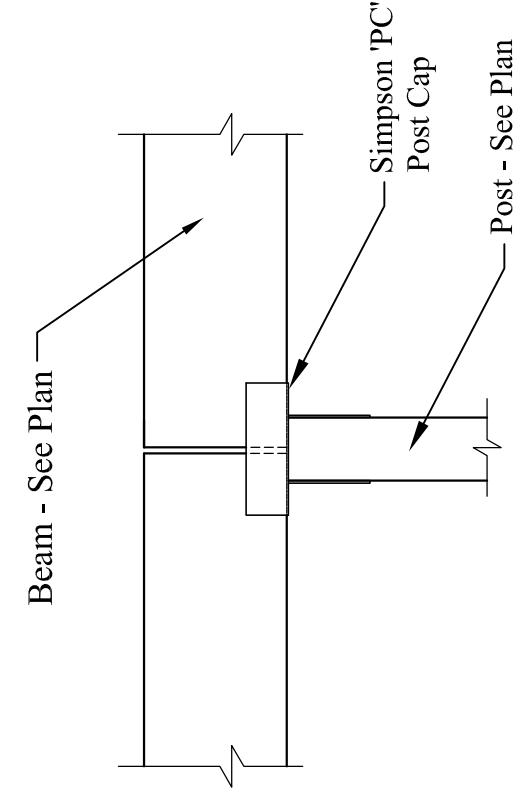

11 WOOD BM. to WOOD POST CONN.
Scale: 3/4" = 1'-0"

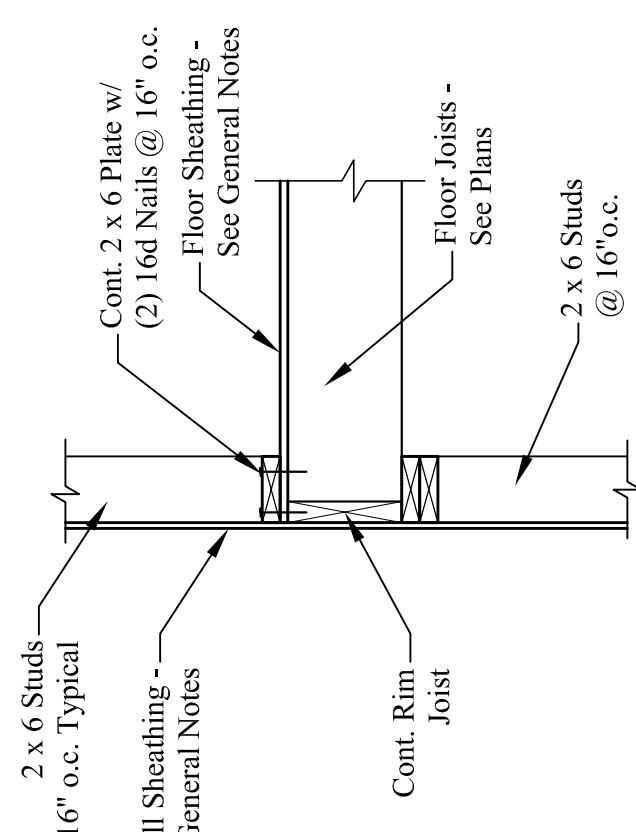

7 FLOOR JOIST @ BRG. WALL
Scale: 3/4" = 1'-0"

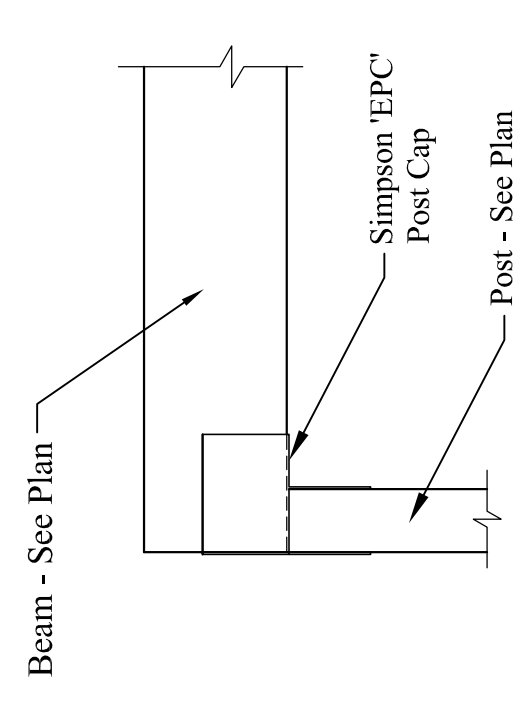

10 WOOD BM. to WOOD POST CONN.
Scale: 3/4" = 1'-0"

NOTE: Field verify thickness of brick masonry wall prior to fabricating steel.

MARK	MEMBER SIZE	WALL TYPE	NOTES
MH-1	(2) 4" x 3 1/2" x 3/8" (LLV)	8" Brick Masonry Wall	Bear 8" at Jambs
MH-3	(2) 8" x 3 1/2" x 3/8" (LLV)	8" Brick Masonry Wall	Steel Support - See Detail 12/S1

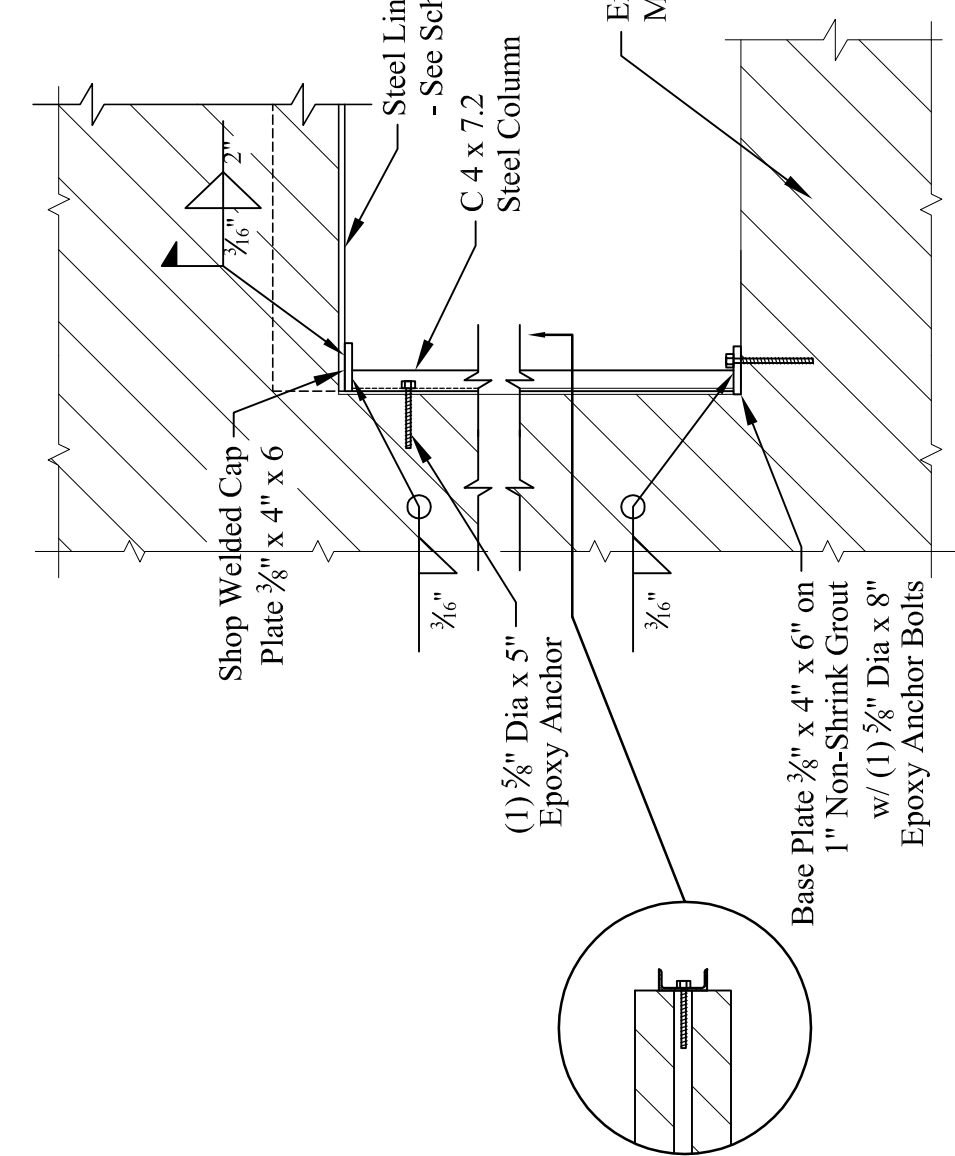

13 TYPICAL MASONRY WALL SUPPORT
Scale: 3/4" = 1'-0"