

GRANT HAYS ASSOCIATES
 ARCHITECTURE & INTERIOR DESIGN
 P.O. BOX 6179 FALMOUTH MAINE 04105
 207.871.5900 www.granthays.com

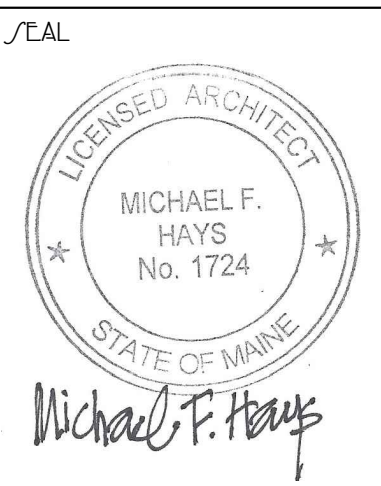

REVISIONS
 12.29.2015
 08.01.2017 EDITS PER PLAN REVIEW

PROJECT NAME
**3 UNIT APARTMENT BUILDING
 162 EASTERN PROMENADE**

162 EASTERN PROMENADE LLC.
 162 EASTERN PROMENADE
 PORTLAND, MAINE 04101

DETAILS & SECTIONS

DATE
 19/EPT 2015
 SCALE
 1/4"=1'-0"
 DRAWN
 JAM/MFH
 JOB NO.
 150815
 SHEET

A10

COPYRIGHT REPRODUCTION OR RELY ON THIS DOCUMENT WITHOUT WRITTEN PERMISSION FROM GRANT HAYS ASSOCIATES IS PROHIBITED.

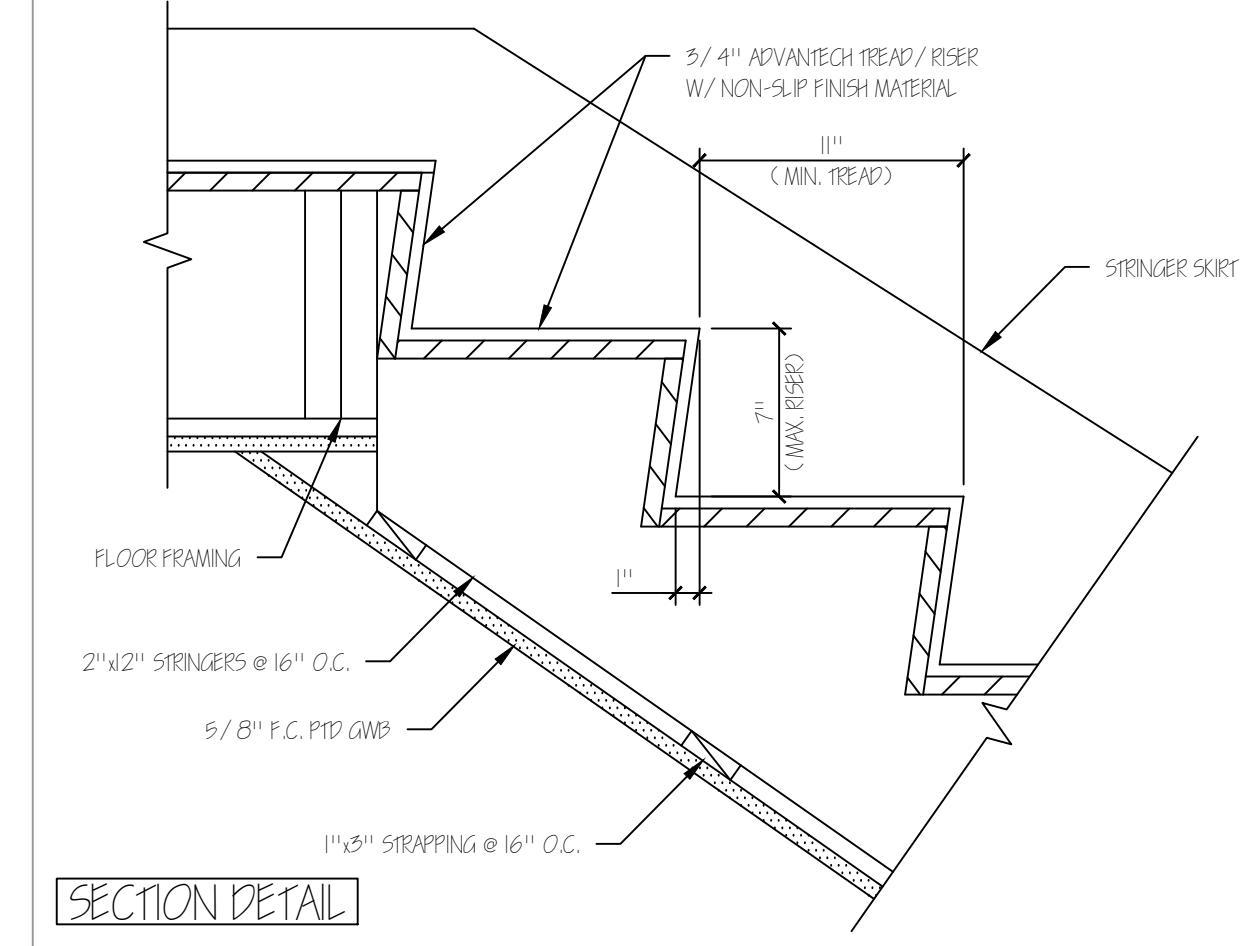

1 INTERIOR STAIR RISER/ TREAD DETAIL 1 1/2"=1'-0"

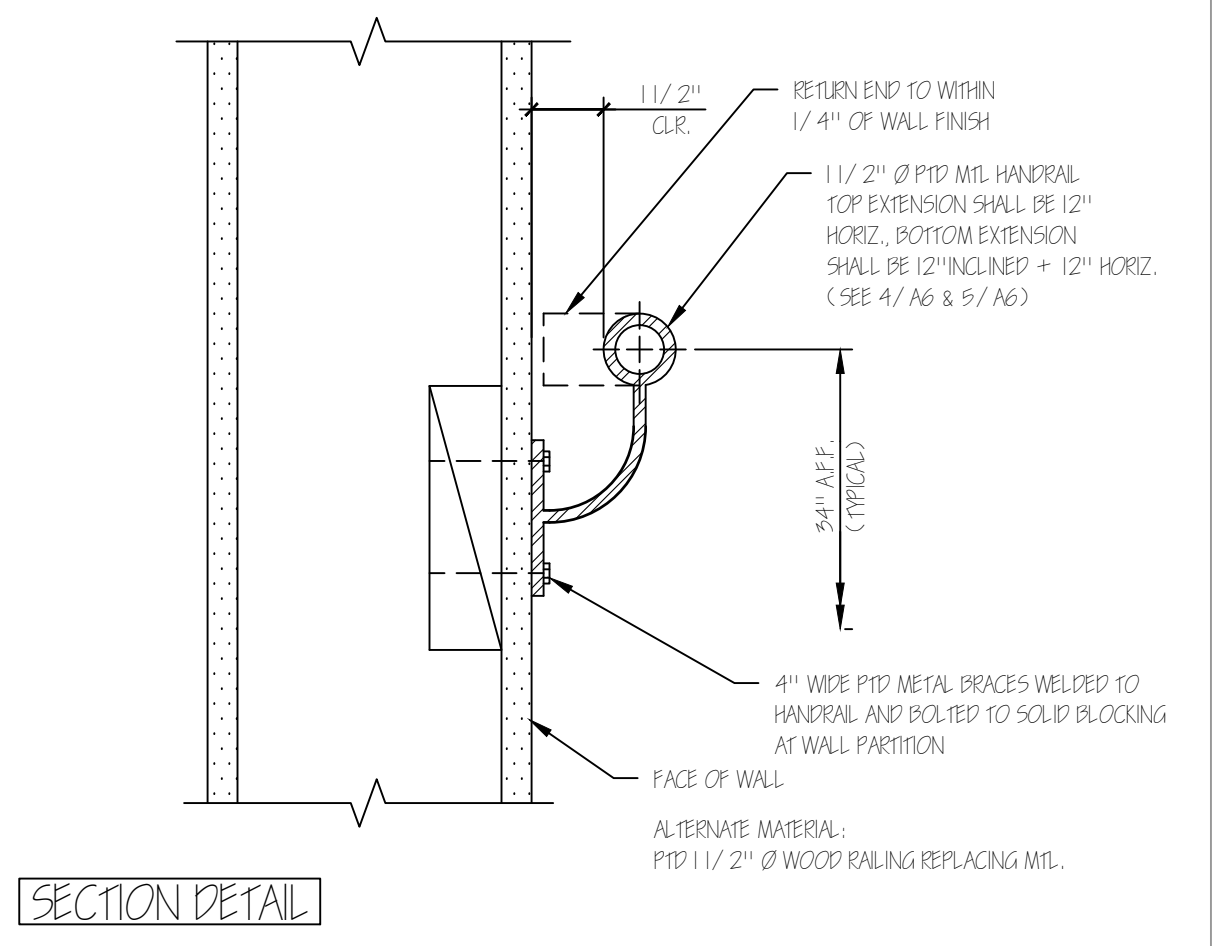

2 TYPICAL WALL HANDRAIL SECTION 3/4"=1'-0"

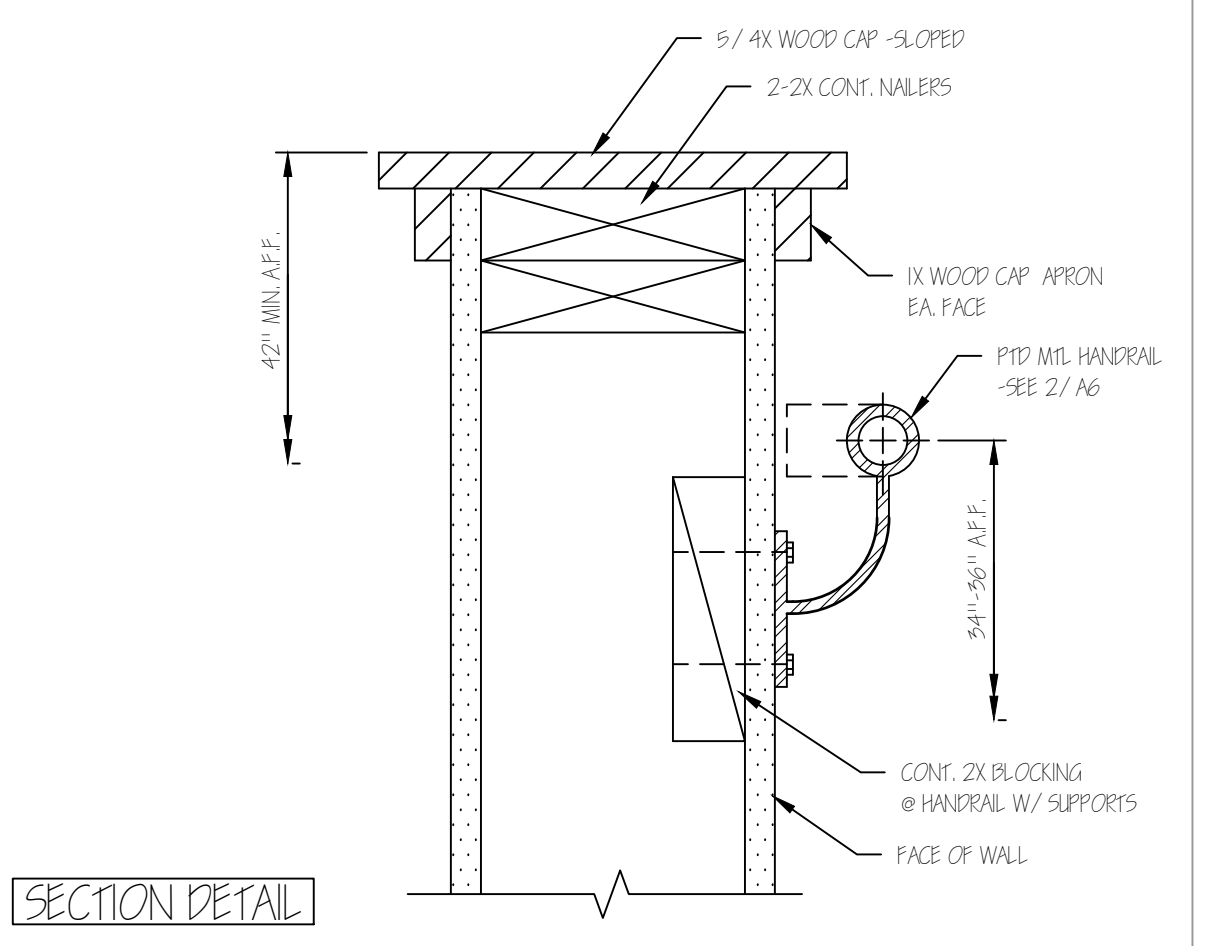

3 STAIR GUARDRAIL 3/4"=1'-0"

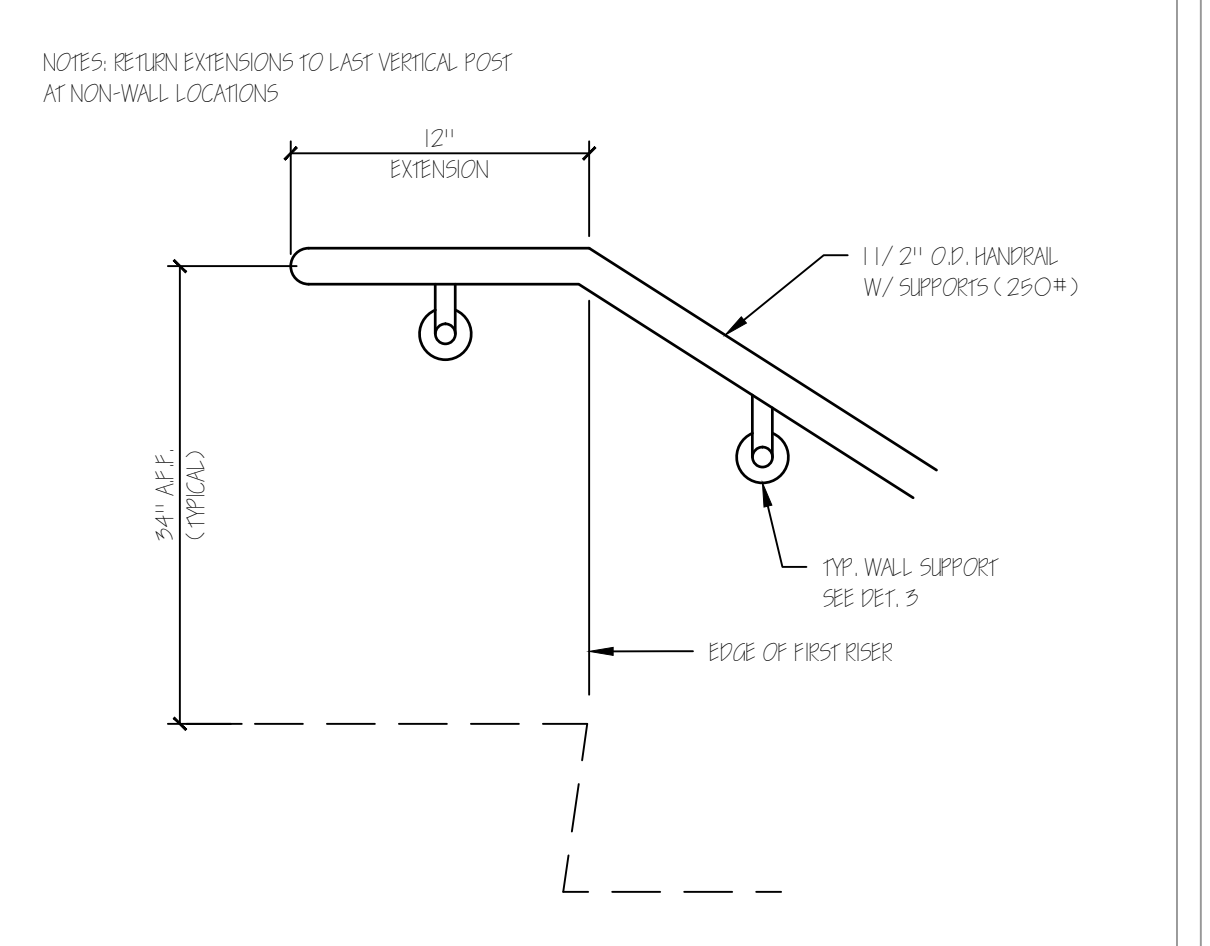

4 TYPICAL WALL HANDRAIL-TOP 3/4"=1'-0"

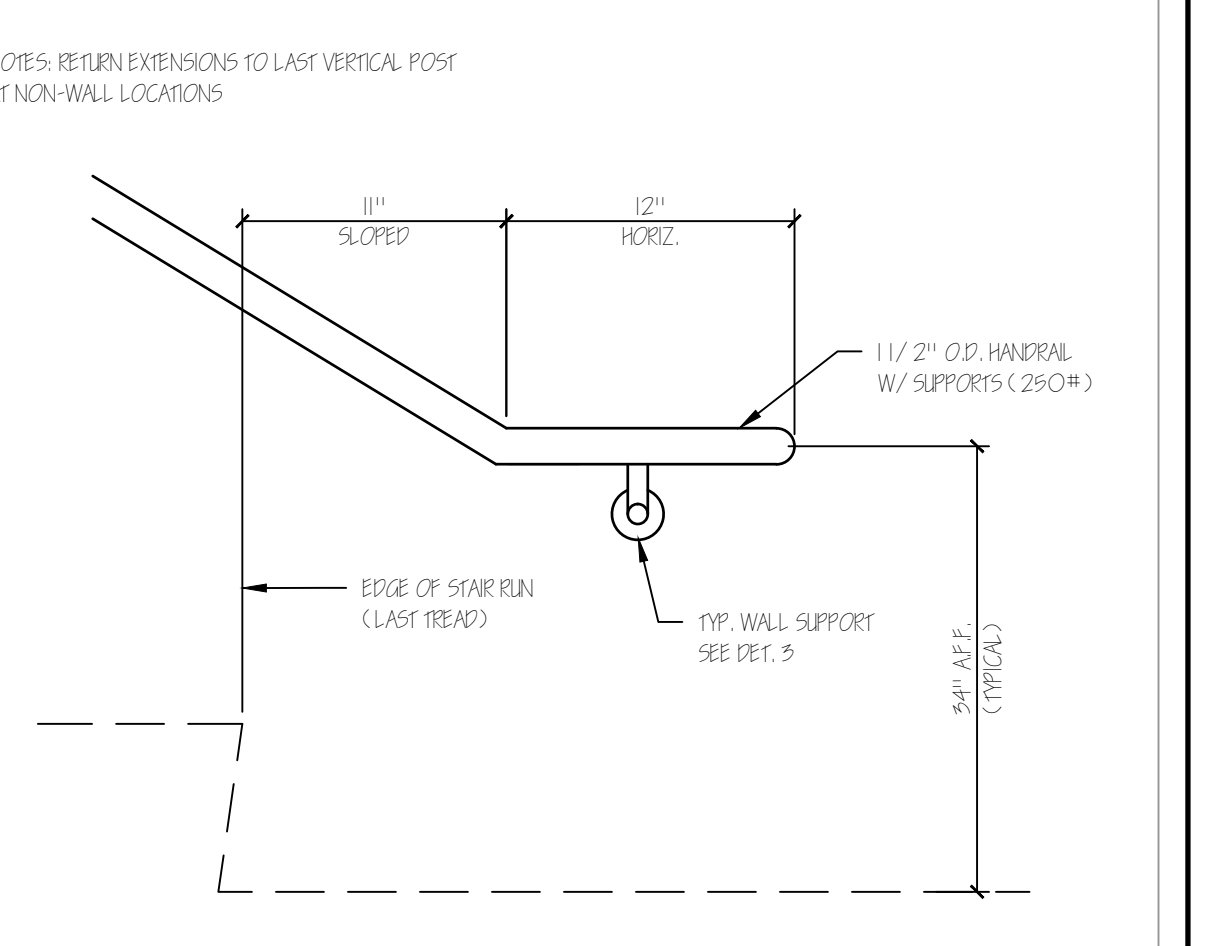

5 TYPICAL WALL HANDRAIL-BOTTOM 3/4"=1'-0"

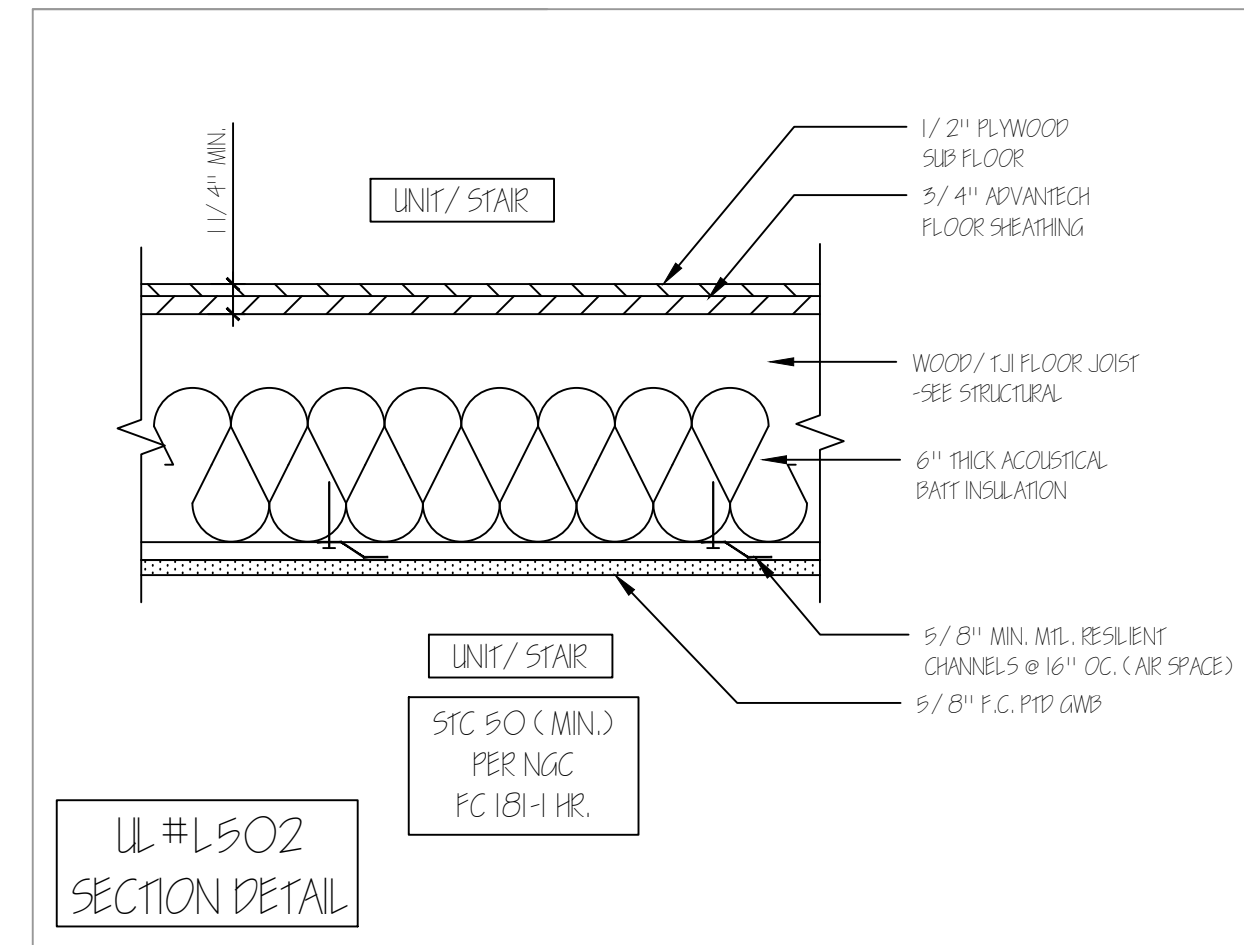

6 1 HR RATED FLOOR/ CEILING ASSEMBLY 1 1/2"=1'-0"

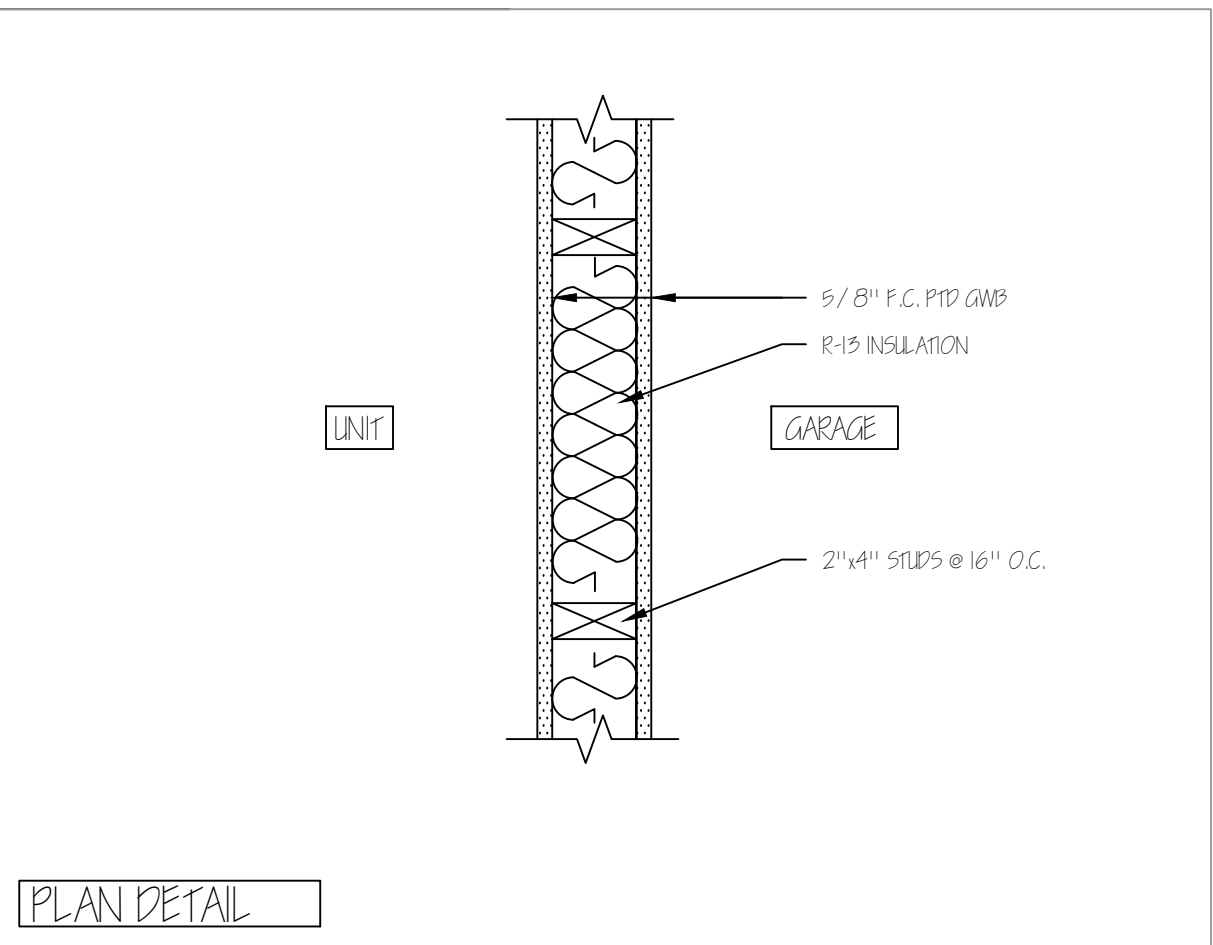

7 1 HR RATED WALL 1 1/2"=1'-0"

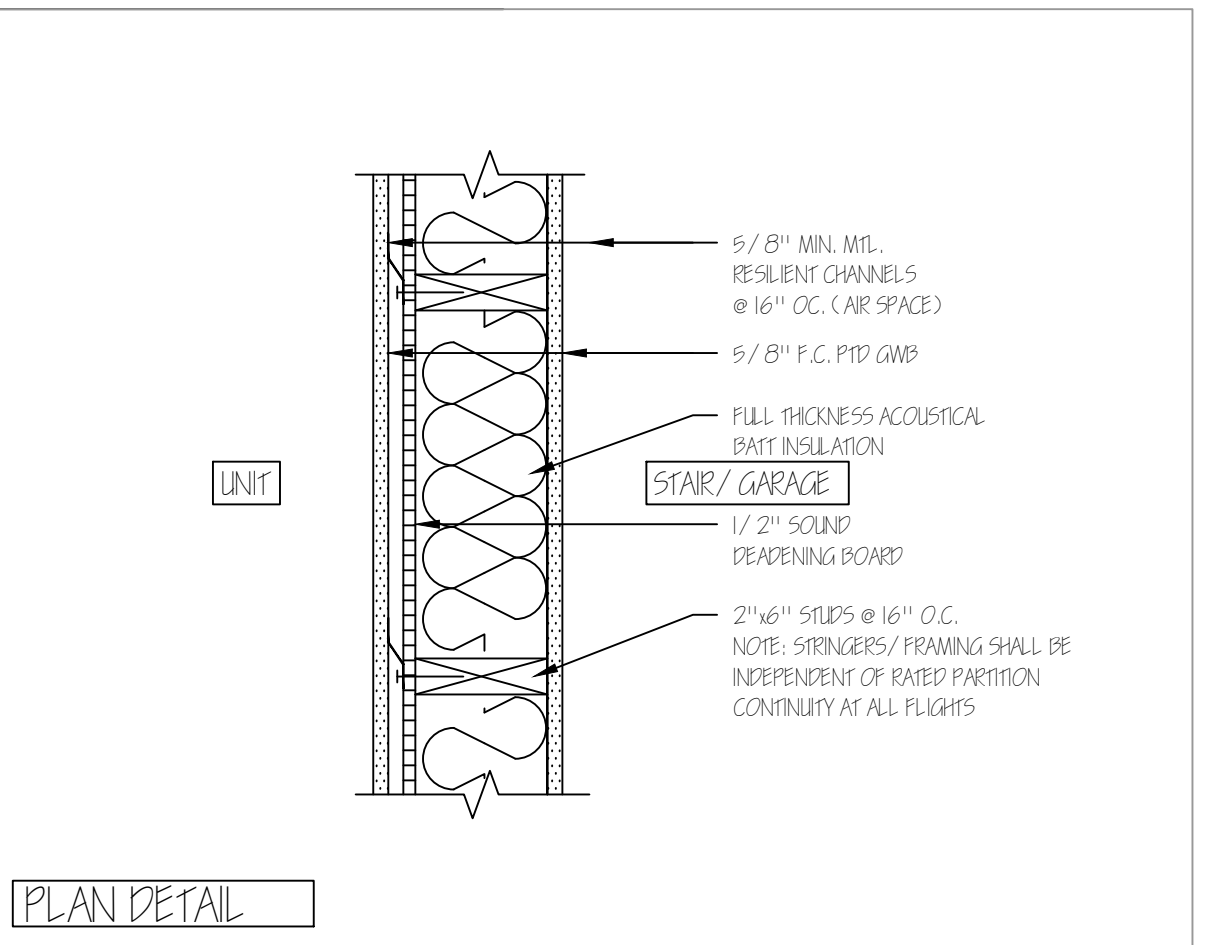

8 1 HR RATED PARTITION AT STAIR/ GARAGE 1 1/2"=1'-0"

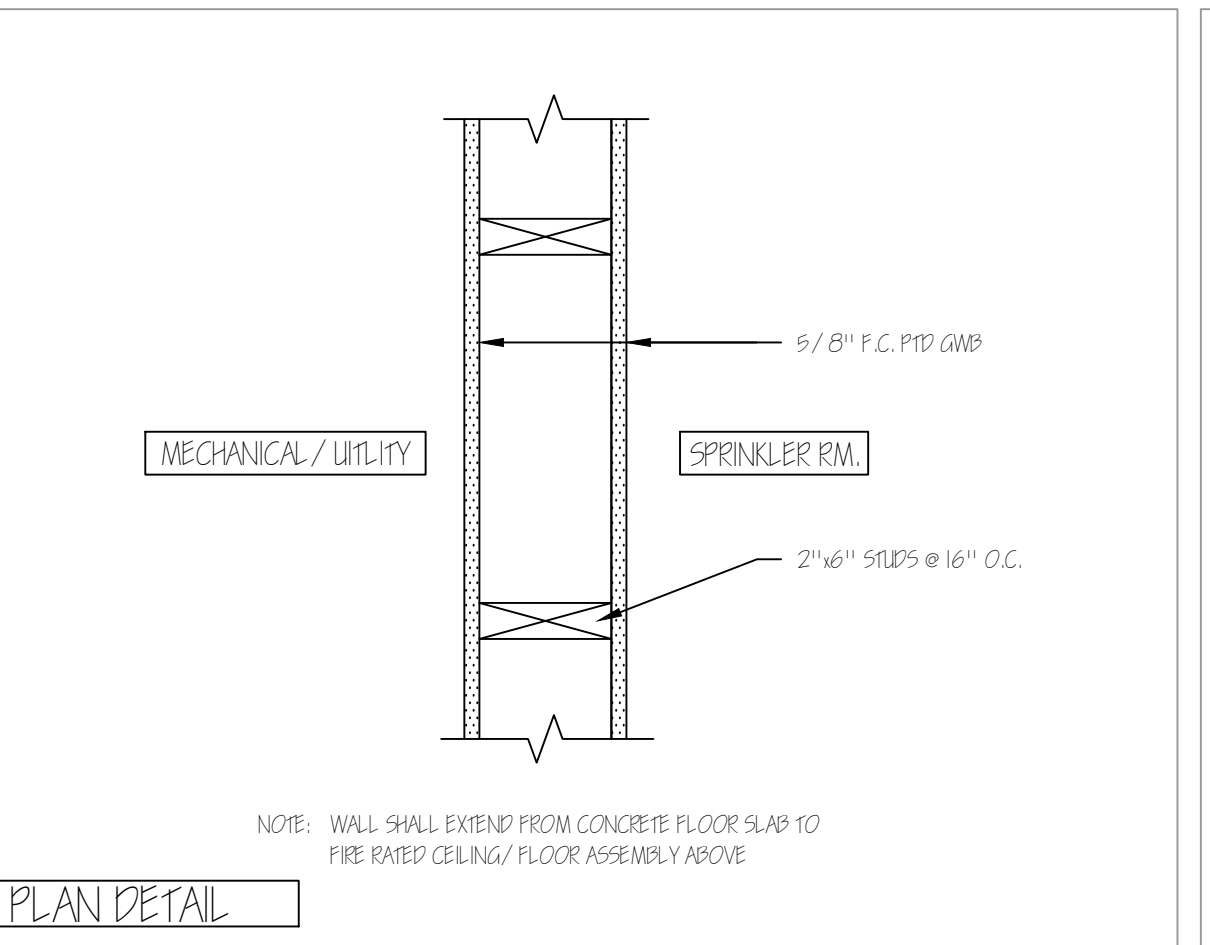

9 1 HR RATED PARTITION AT SPRINKLER ROOM 1 1/2"=1'-0"

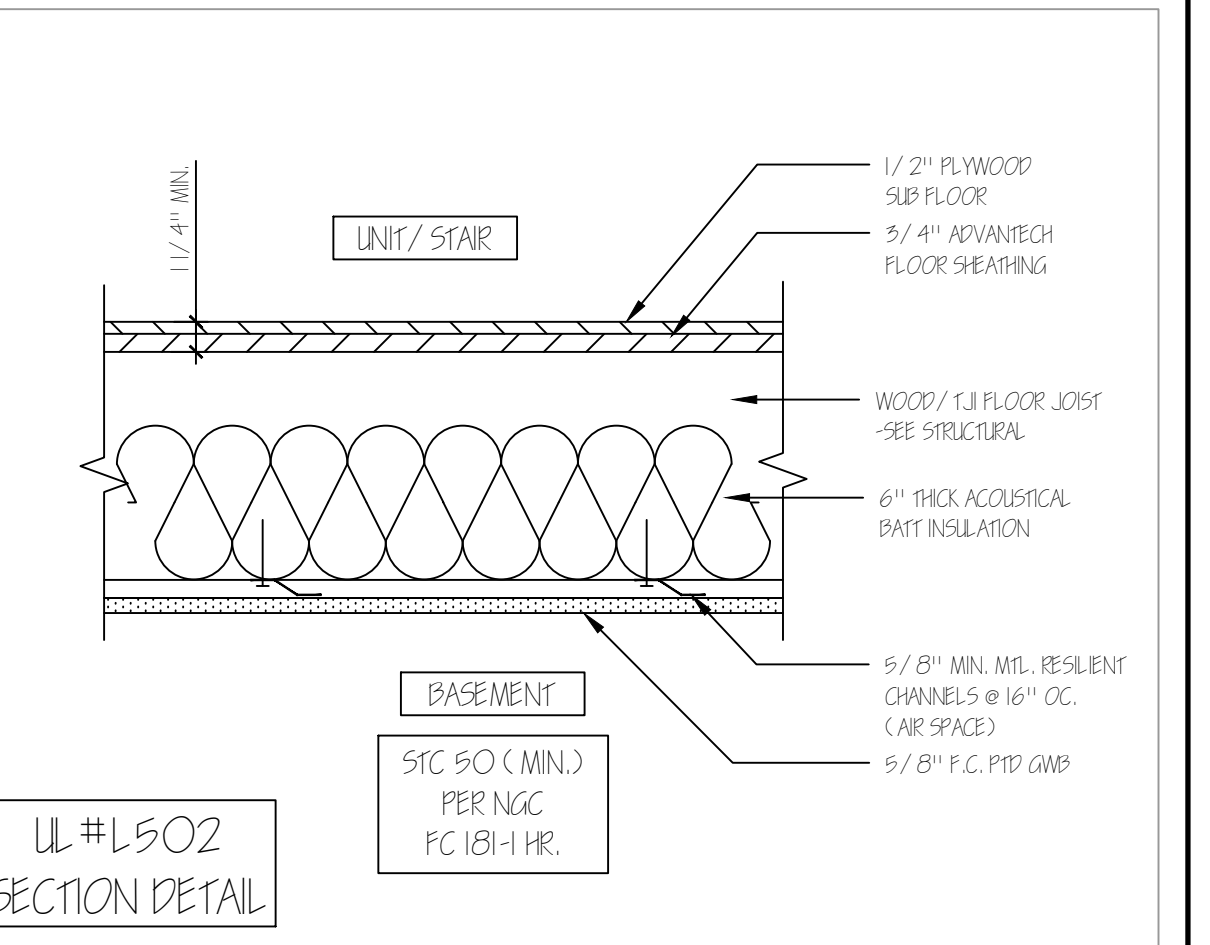

10 1 HR RATED FIRST FLOOR ASSEMBLY 1 1/2"=1'-0"

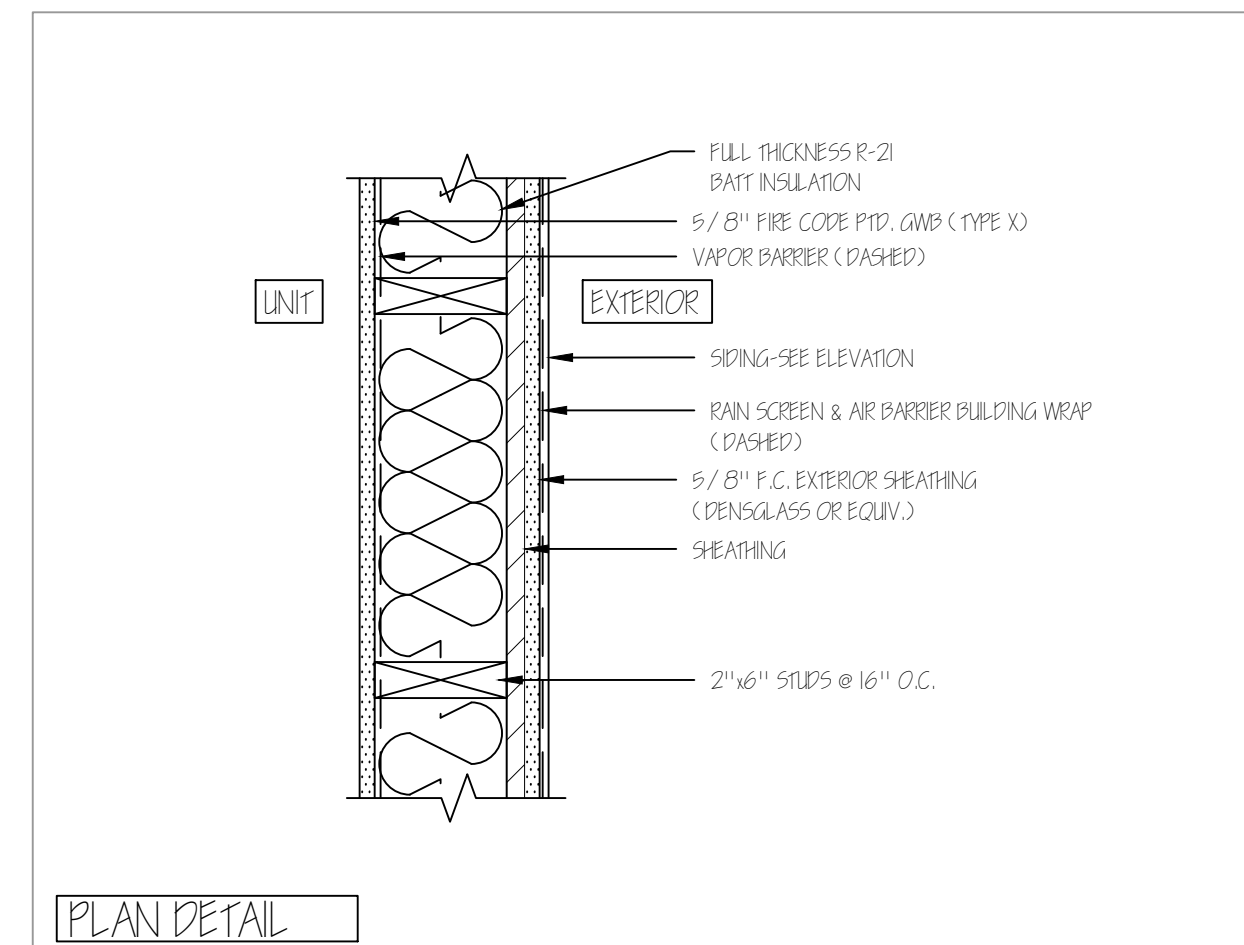

11 1 HR RATED EXTERIOR WALL ASSEMBLY 1 1/2"=1'-0"

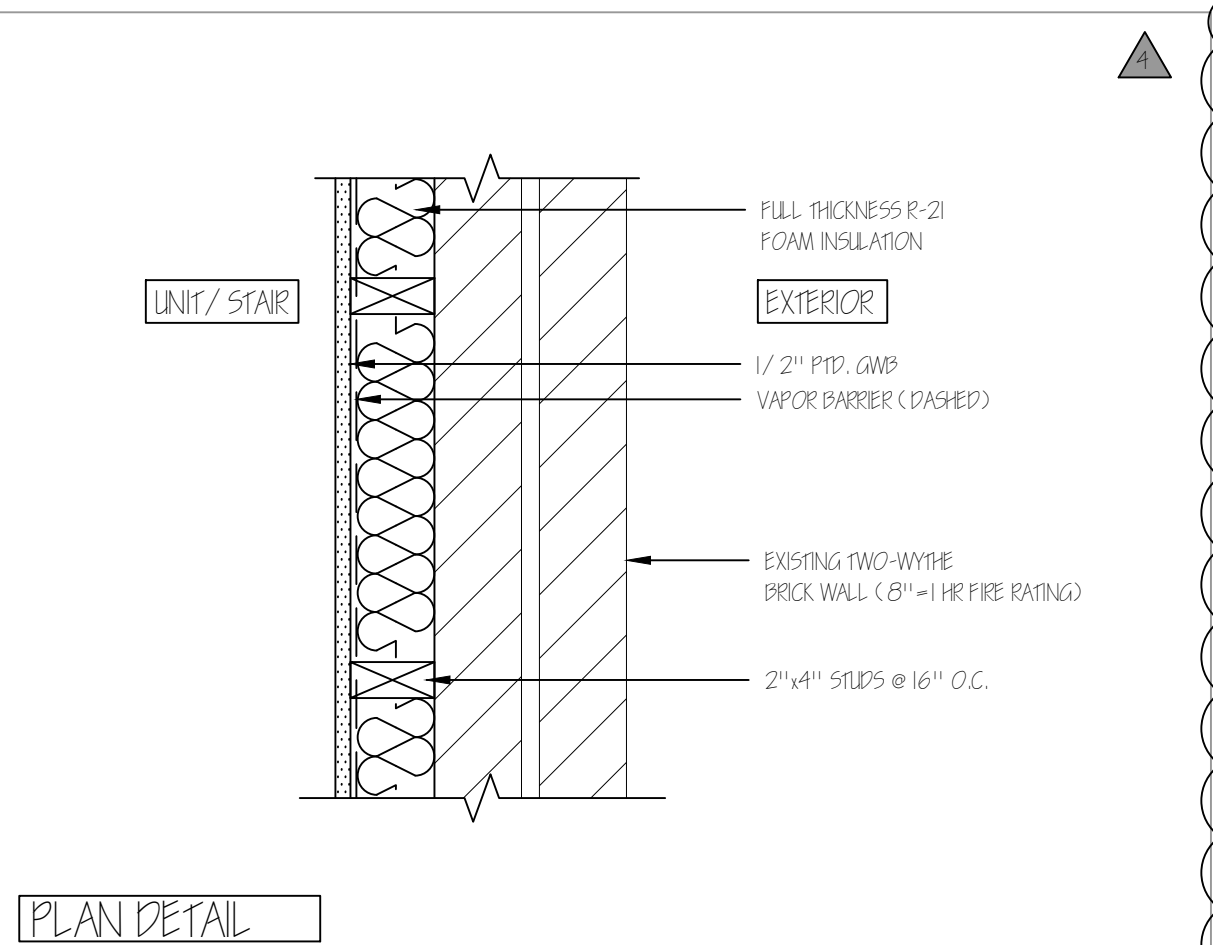

12 EXTERIOR WALL @ 1 HR MASONRY (8" BRICK) 1 1/2"=1'-0"

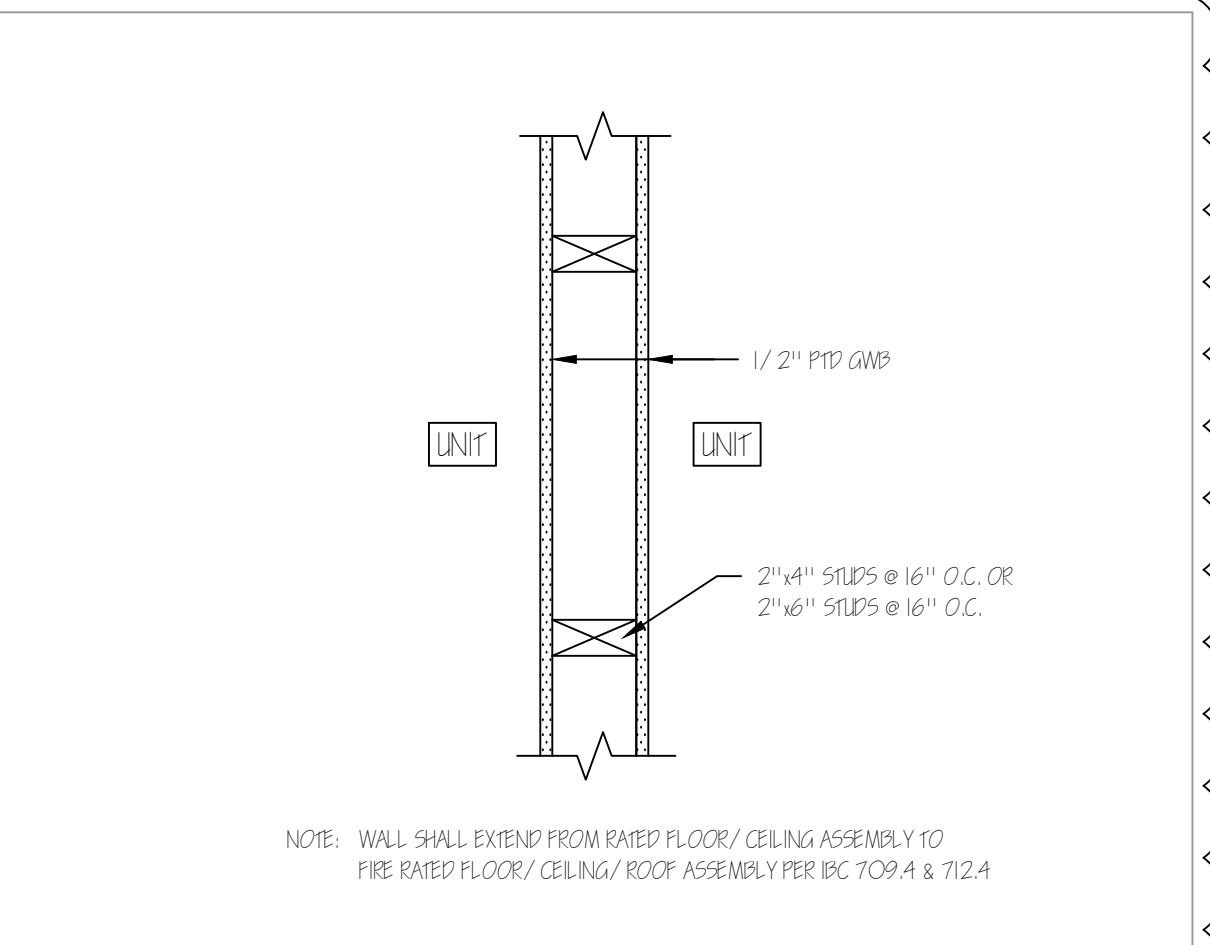

13 TYPICAL INTERIOR WALL (NON-RATED) 1 1/2"=1'-0"

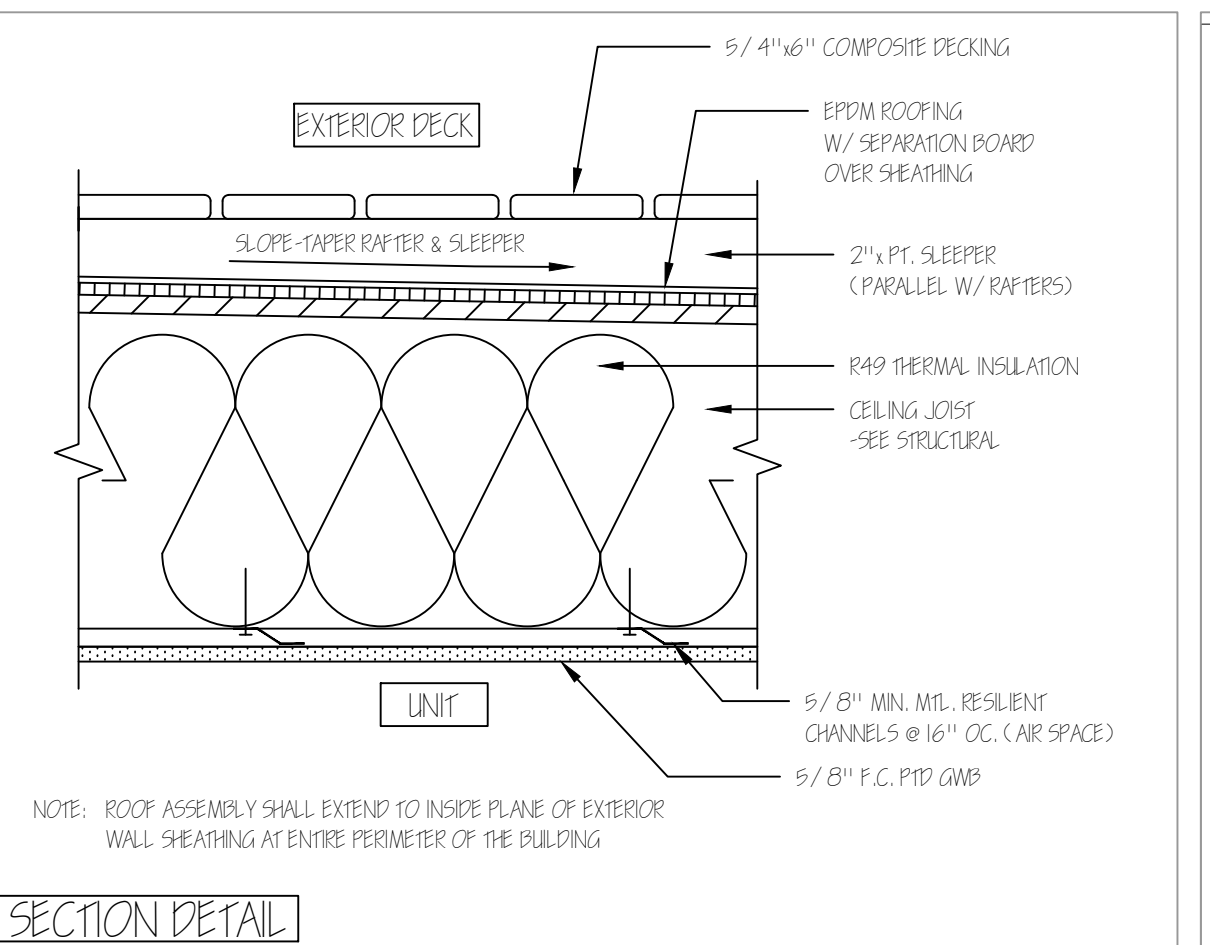

14 1 HR RATED CEILING/ ROOF/ DECK ASSEMBLY 1 1/2"=1'-0"

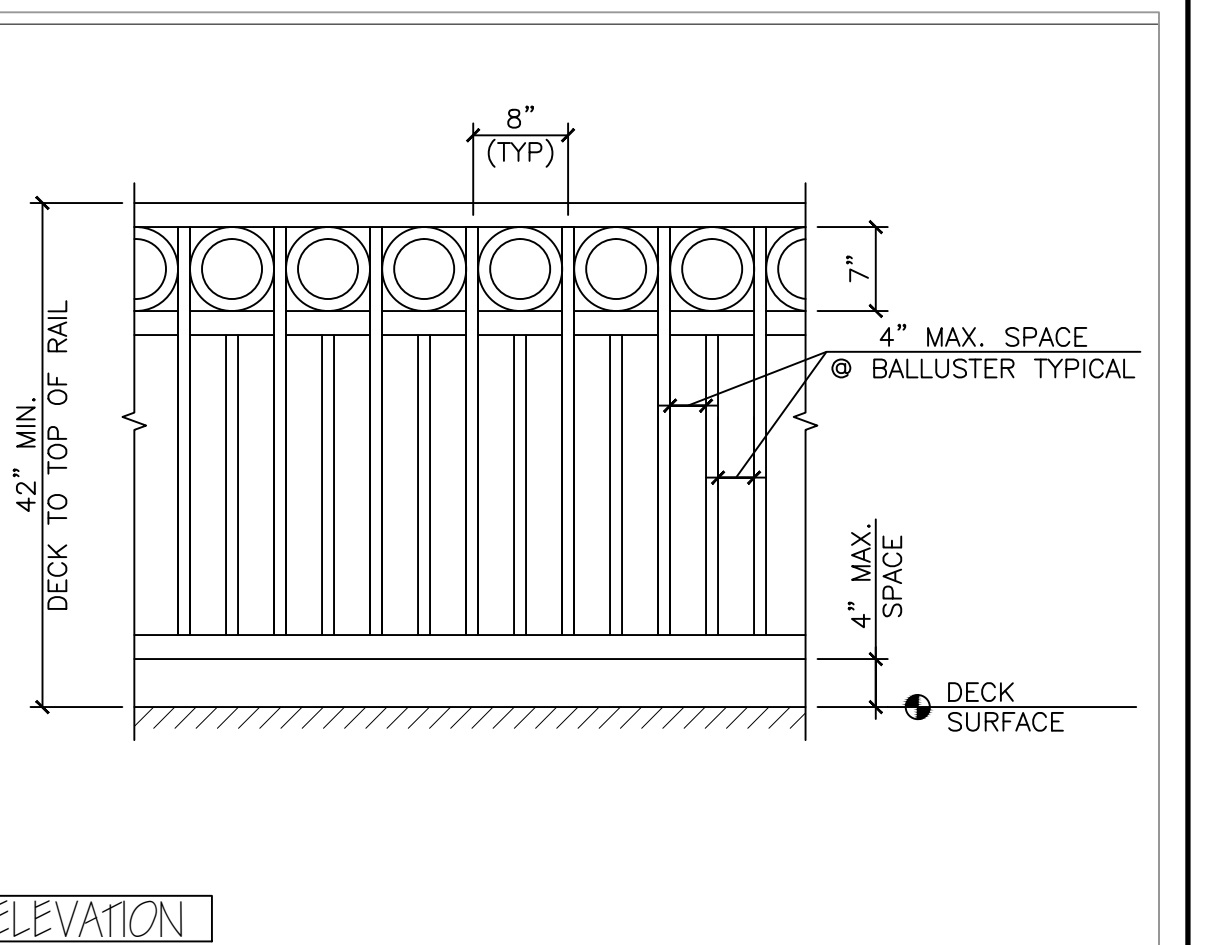

15 TYPICAL DECK GUARDRAIL 3/4"=1'-0"

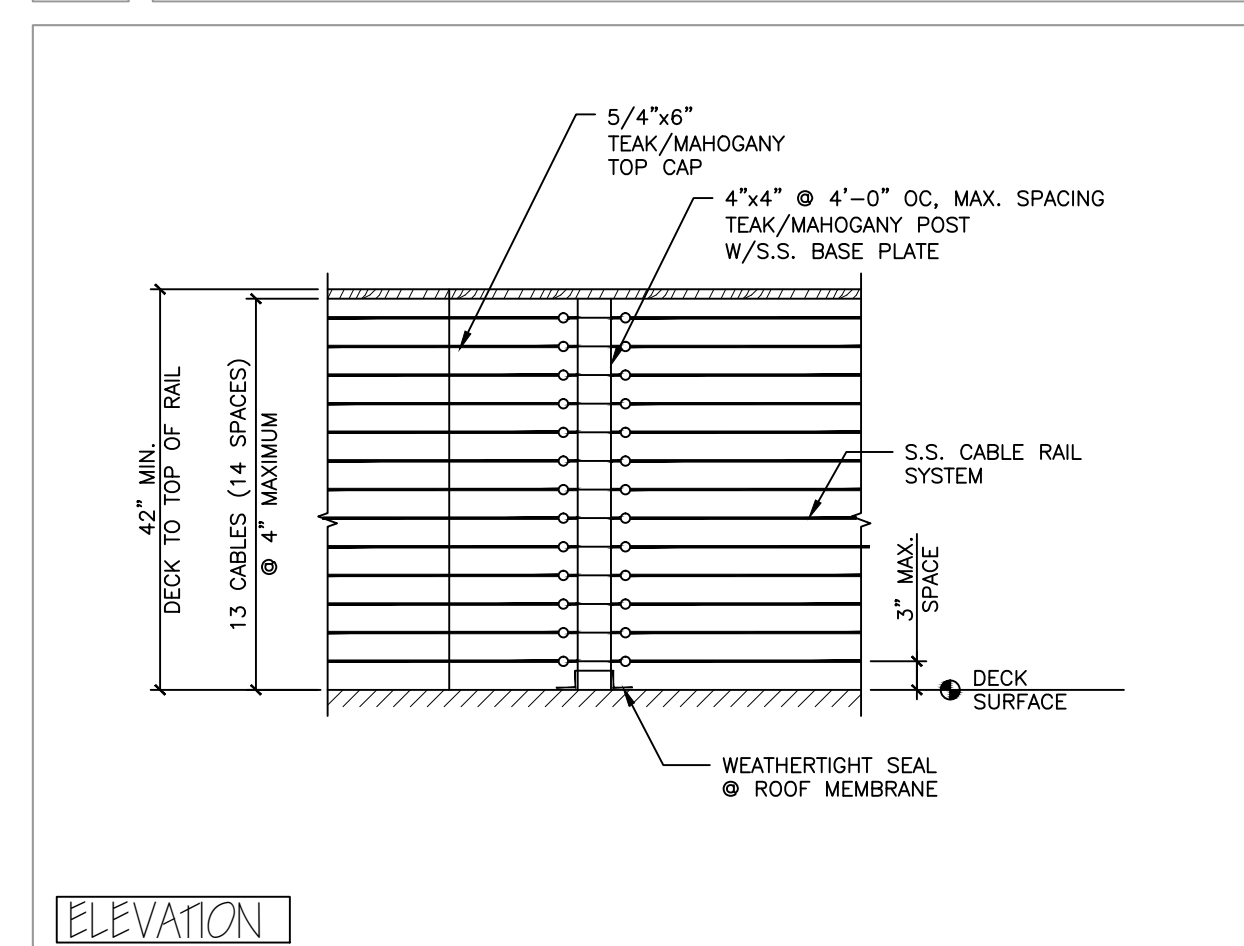

16 TYPICAL CABLERAIL DECK GUARDRAIL 3/4"=1'-0"

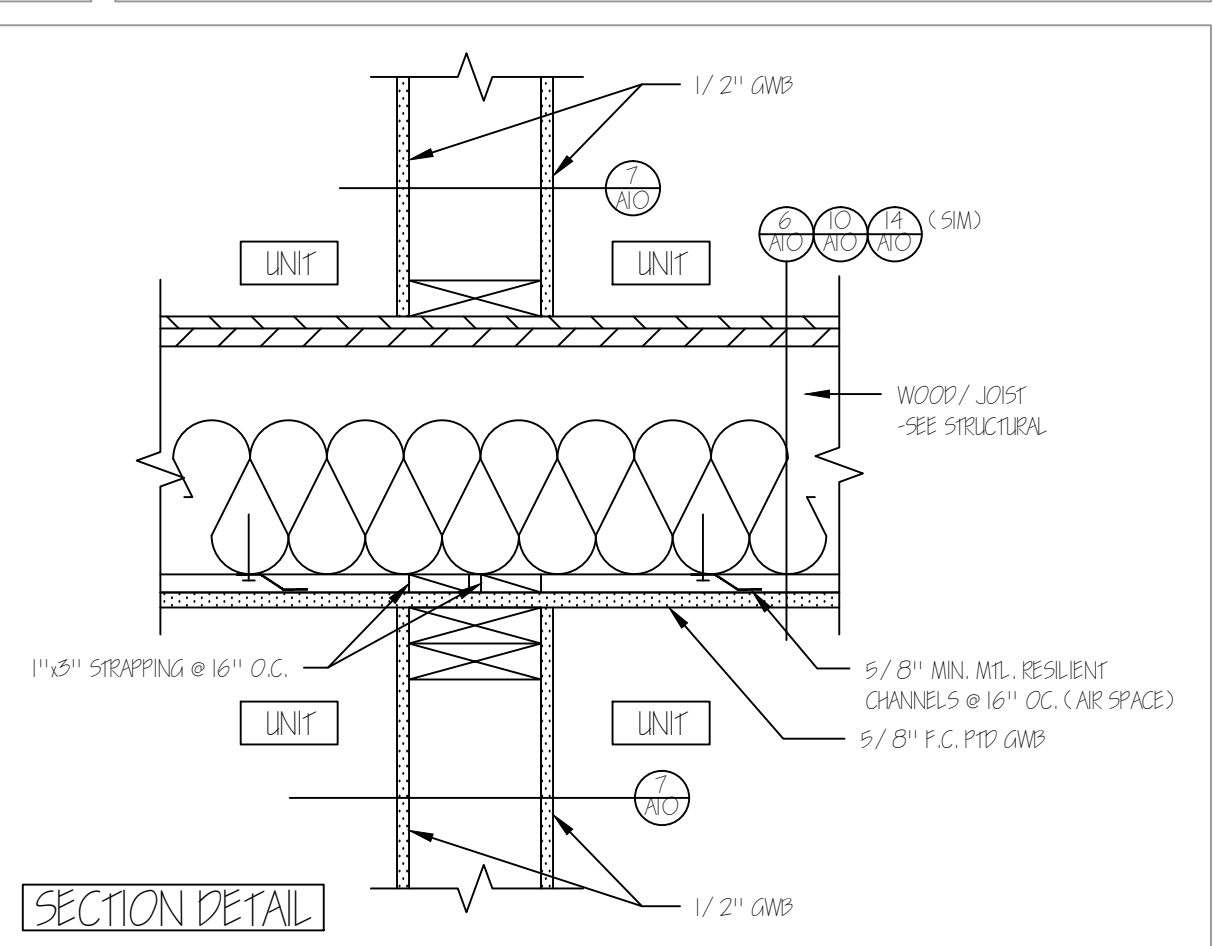

17 NON-RATED PARTITION @ 1 HR. FIRE RATED FLOOR/ CEILING ASSEMBLY 1 1/2"=1'-0"

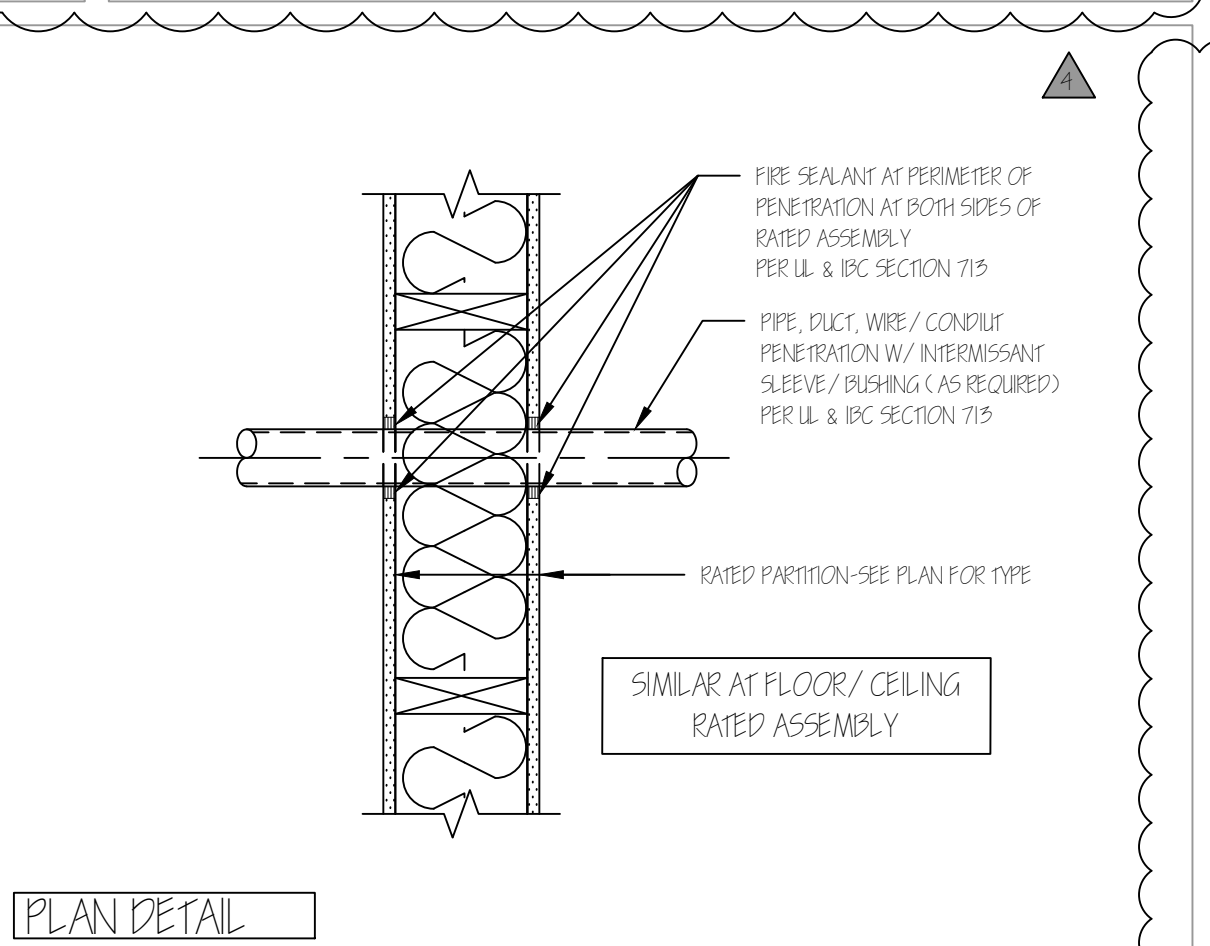

18 FIRE SEALANT @ PENETRATIONS 1 1/2"=1'-0"

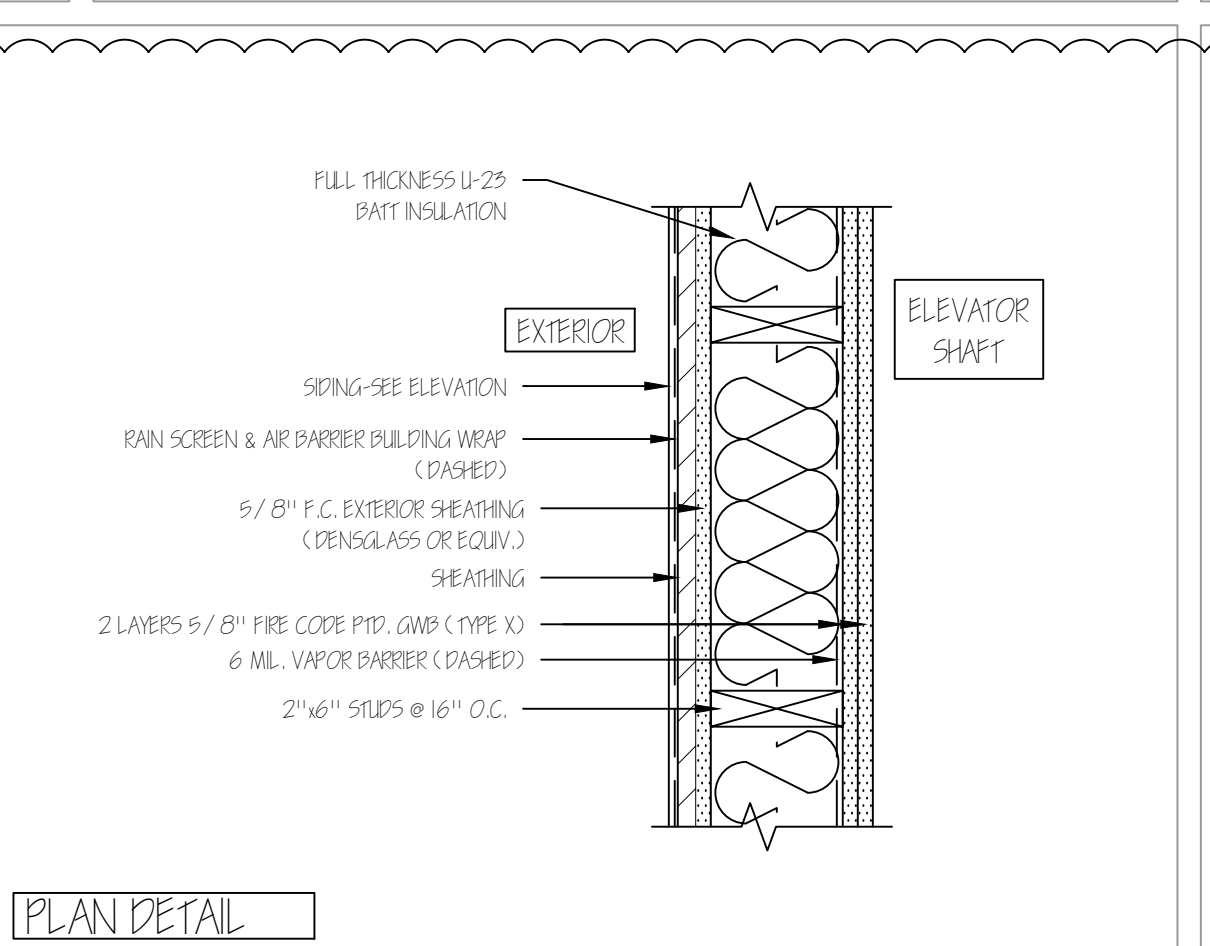

19 2 HR RATED EXTERIOR WALL @ ELEVATOR 1 1/2"=1'-0"

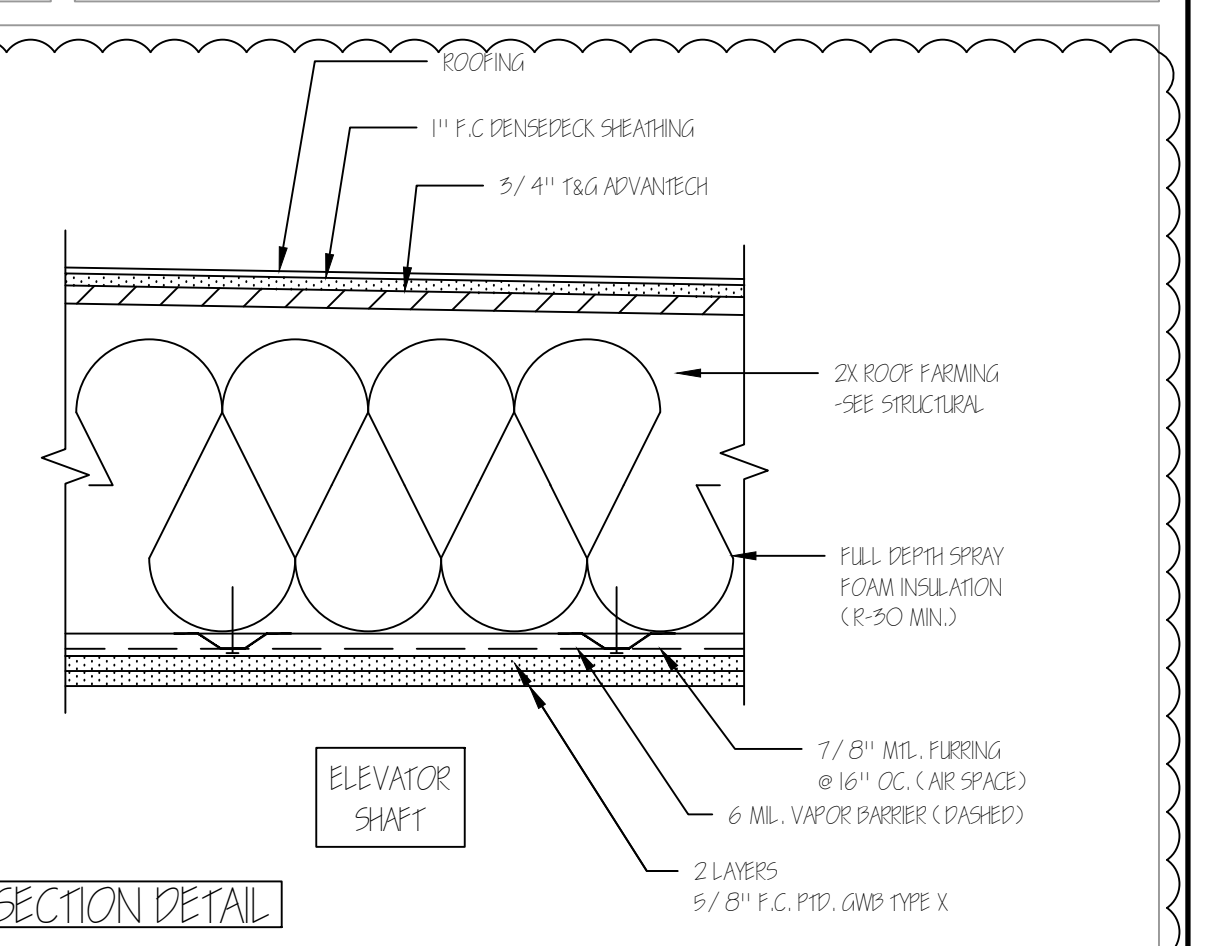

20 2 HR RATED CEILING/ ROOF @ ELEVATOR 1 1/2"=1'-0"