

GRANT HAYS ASSOCIATES
 ARCHITECTURE & INTERIOR DESIGN
 P.O. BOX 6179 FALMOUTH MAINE 04105
 207.871.5900 www.granthays.com

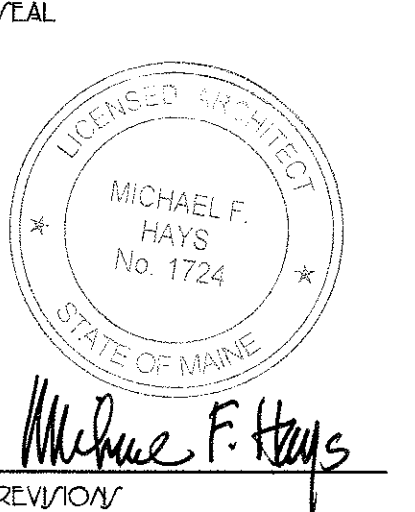

REVISION
 12.29.2015

PROJECT NAME

**3 UNIT APARTMENT BUILDING
 162 EASTERN PROMENADE**
 162 EASTERN PROMENADE LLC.
 162 EASTERN PROMENADE
 PORTLAND, MAINE 04101

SHEET

DETAILS & SECTION

DATE: 19/EPT 2015
 SCALE: 1/4"=1'-0"
 DRAWN: JAM/MFH
 JOB NO: 150815
 SHEET

A10
 COPYRIGHT REPRODUCTION OR REVUE OF THIS DOCUMENT WITHOUT WRITTEN PERMISSION FROM GRANT HAYS ASSOCIATES IS PROHIBITED.

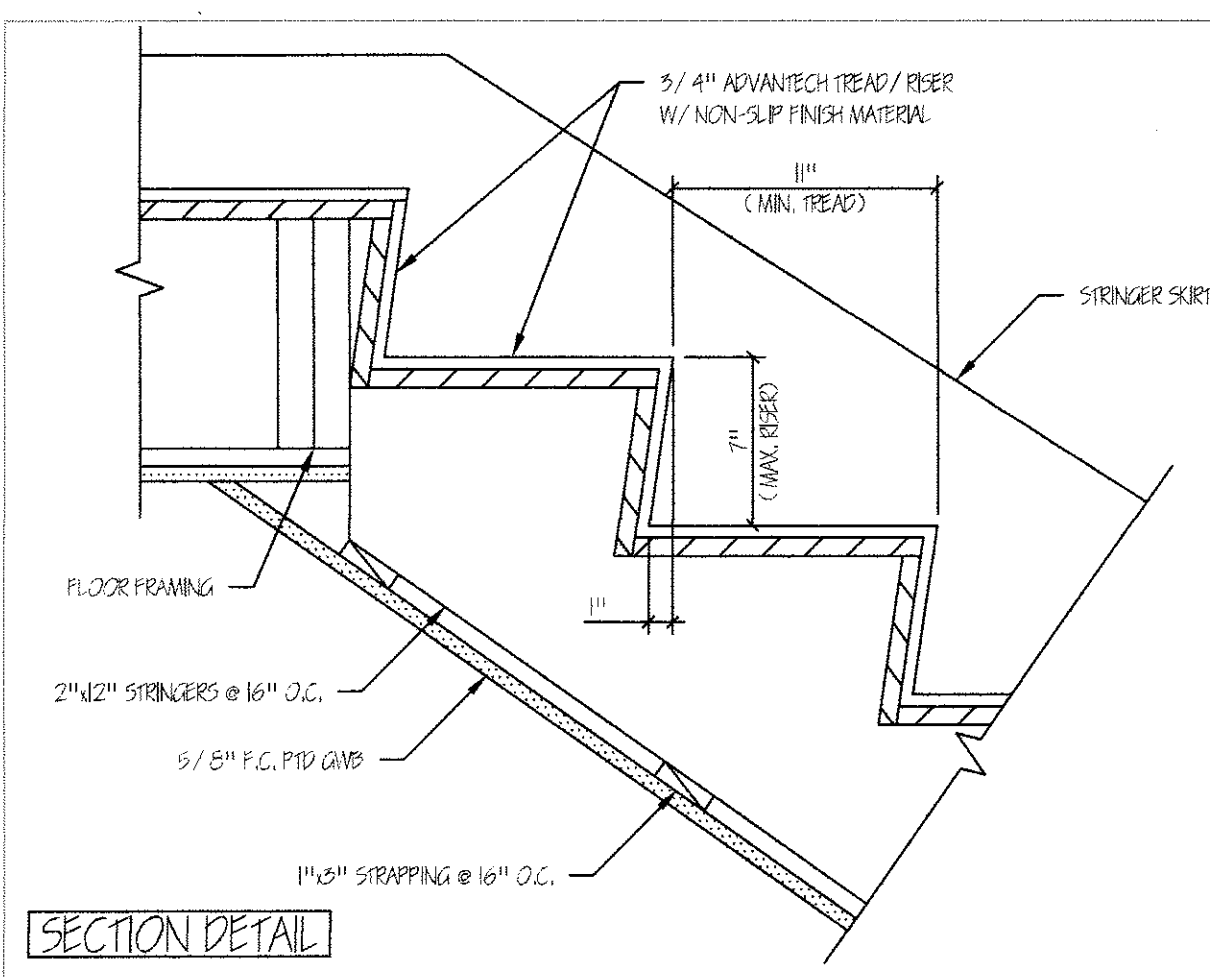

1 INTERIOR STAIR RISER/TREAD DETAIL 1 1/2"=1'-0"

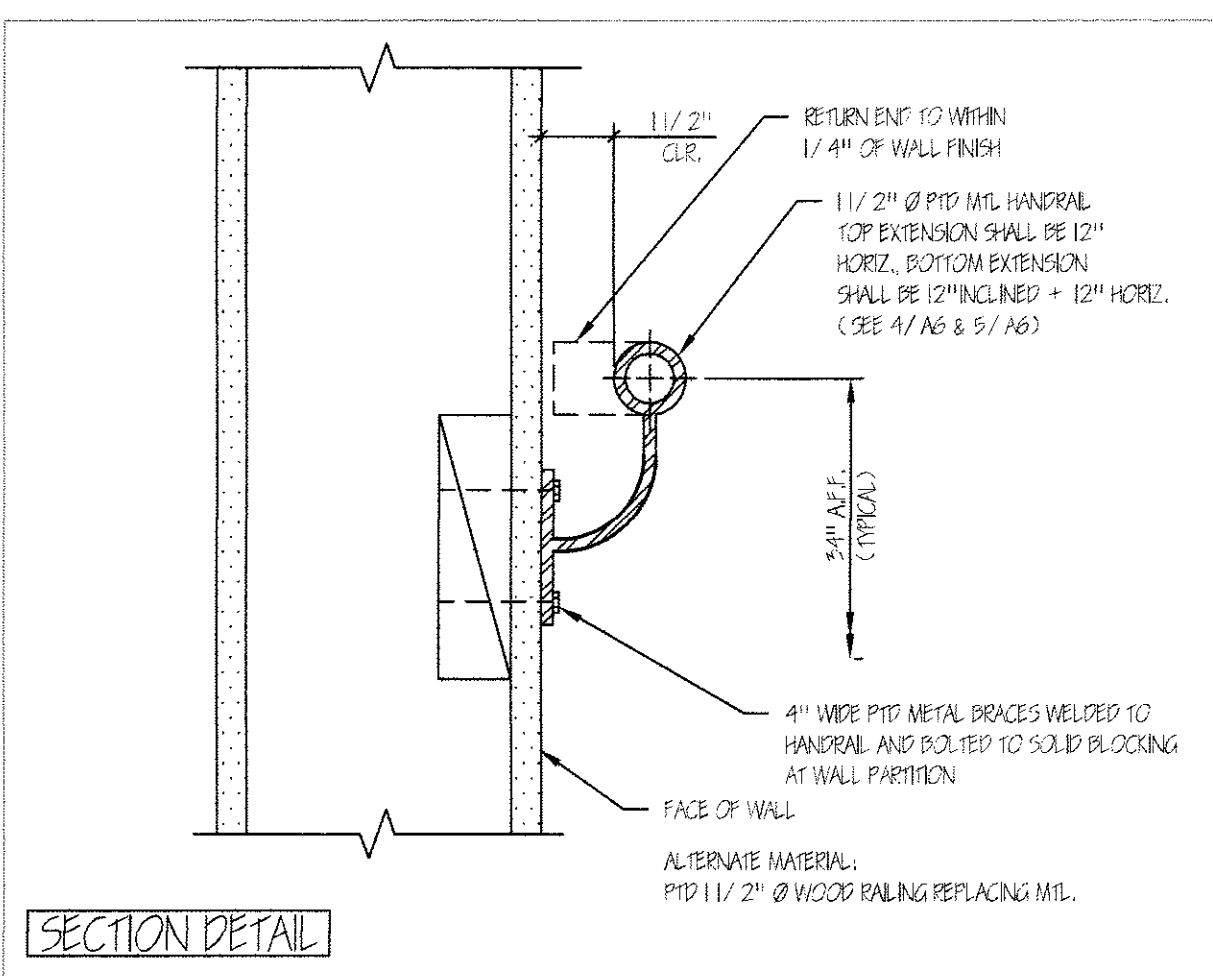

2 TYPICAL WALL HANDRAIL SECTION 3/4"=1'-0"

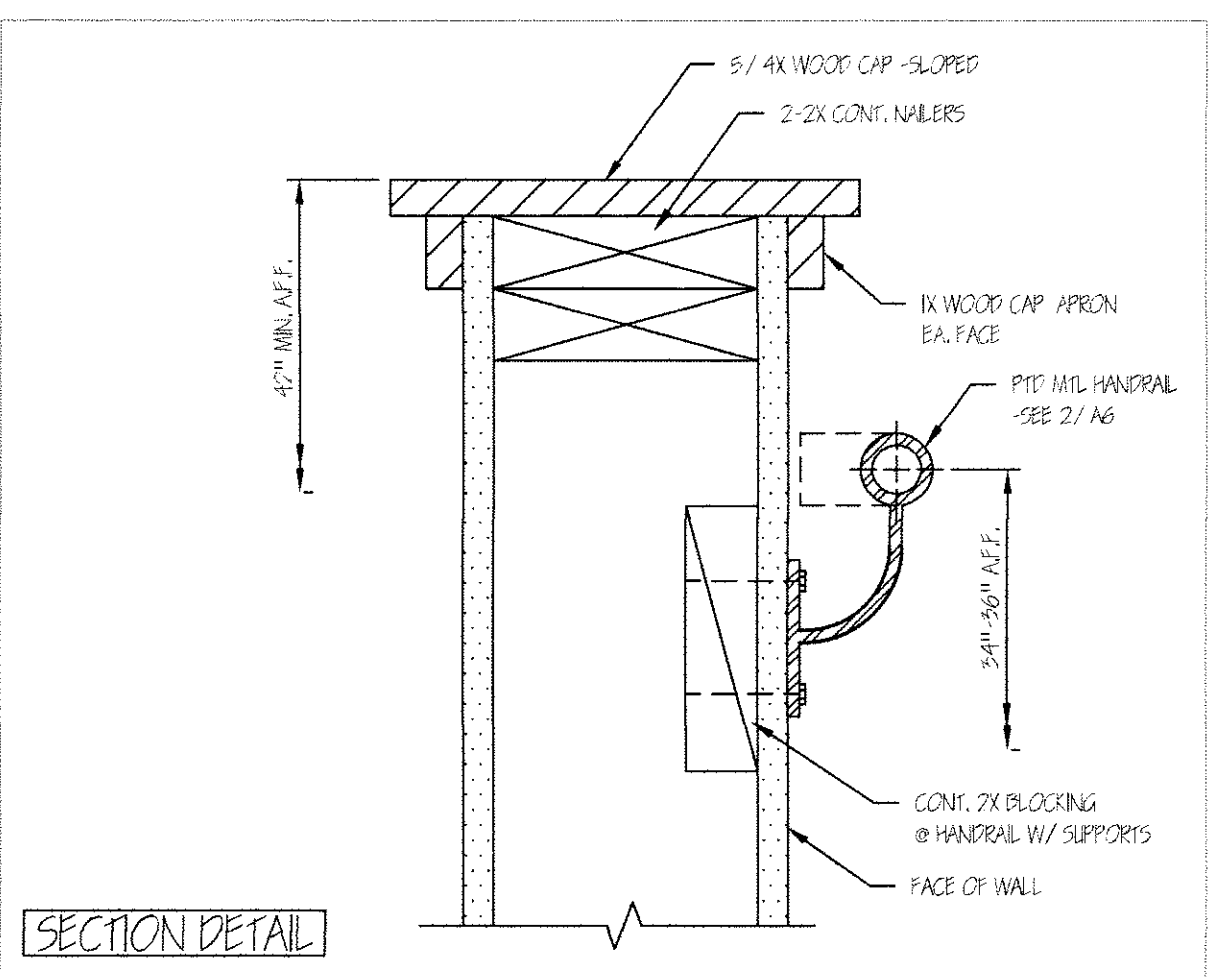

3 STAIR GUARDRAIL 3/4"=1'-0"

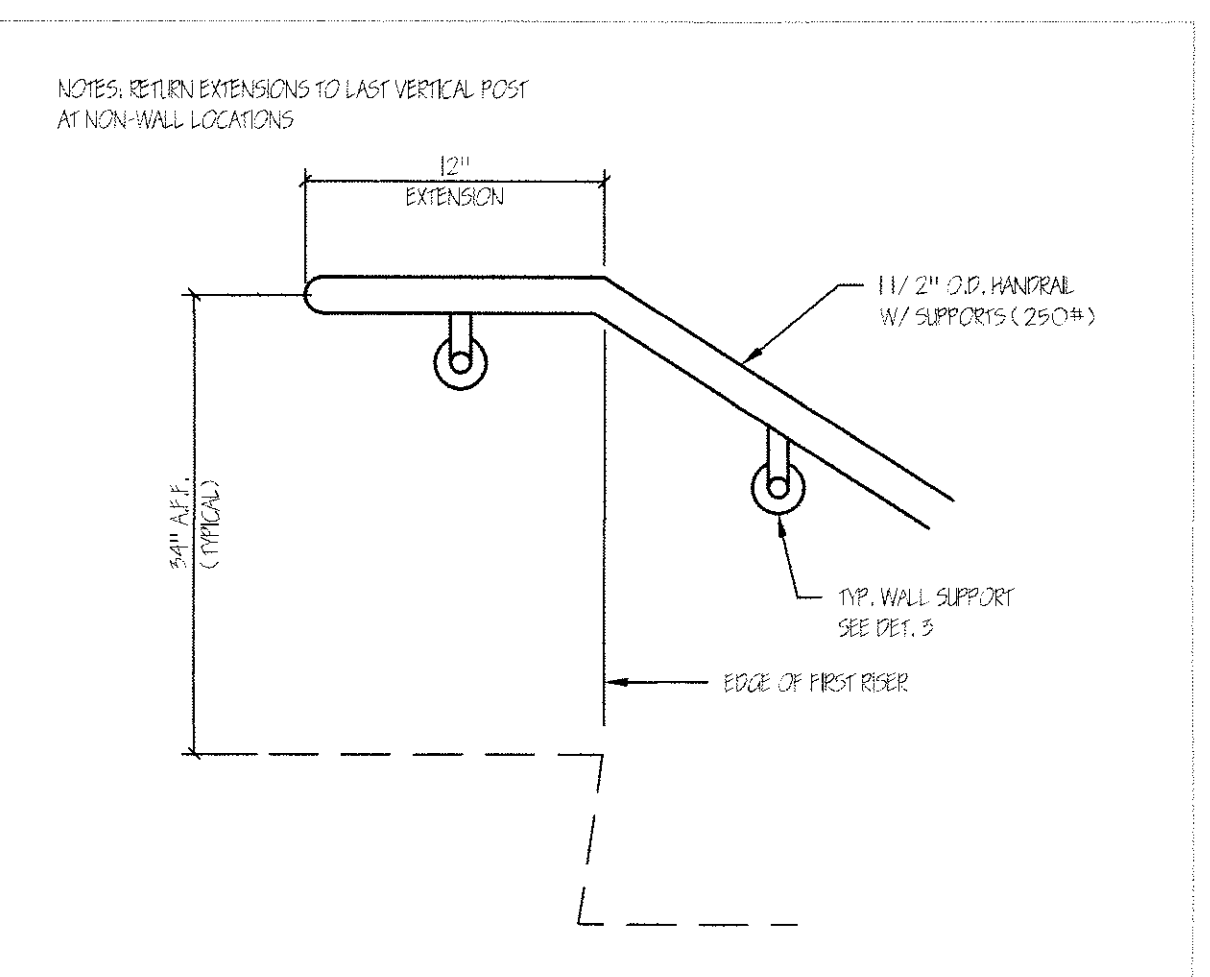

4 TYPICAL WALL HANDRAIL-TOP 3/4"=1'-0"

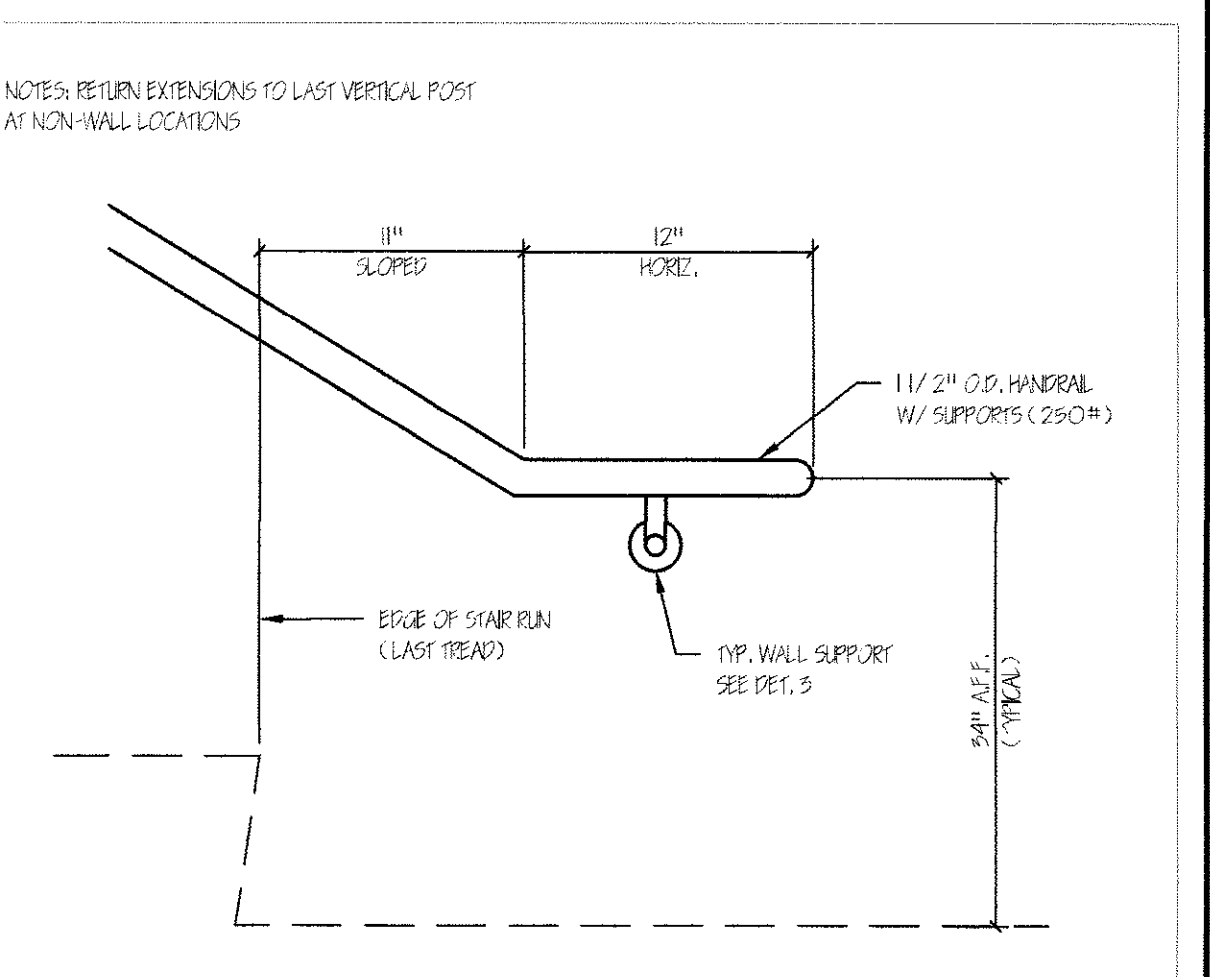

5 TYPICAL WALL HANDRAIL-BOTTOM 3/4"=1'-0"

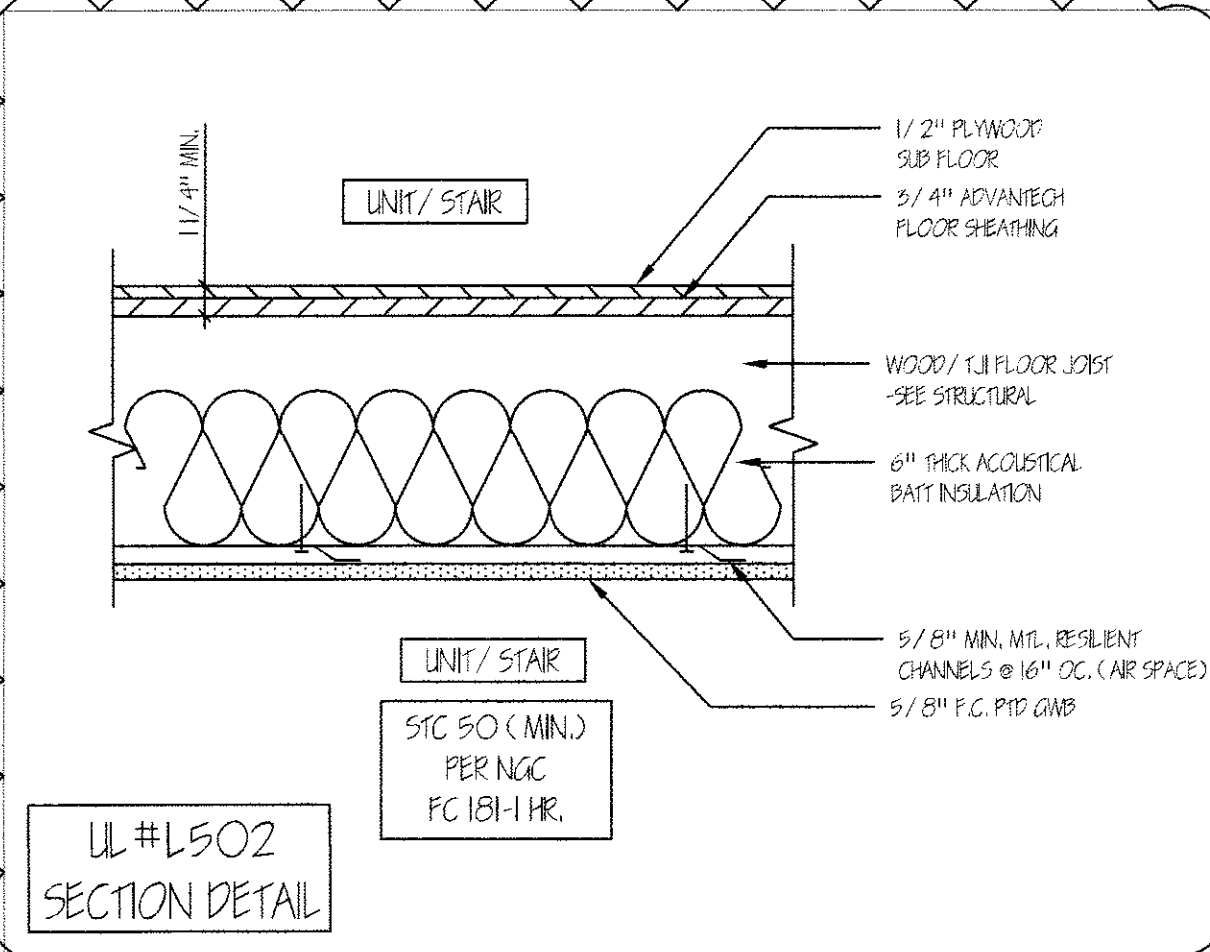

6 1 HR RATED FLOOR/CEILING ASSEMBLY 1 1/2"=1'-0"

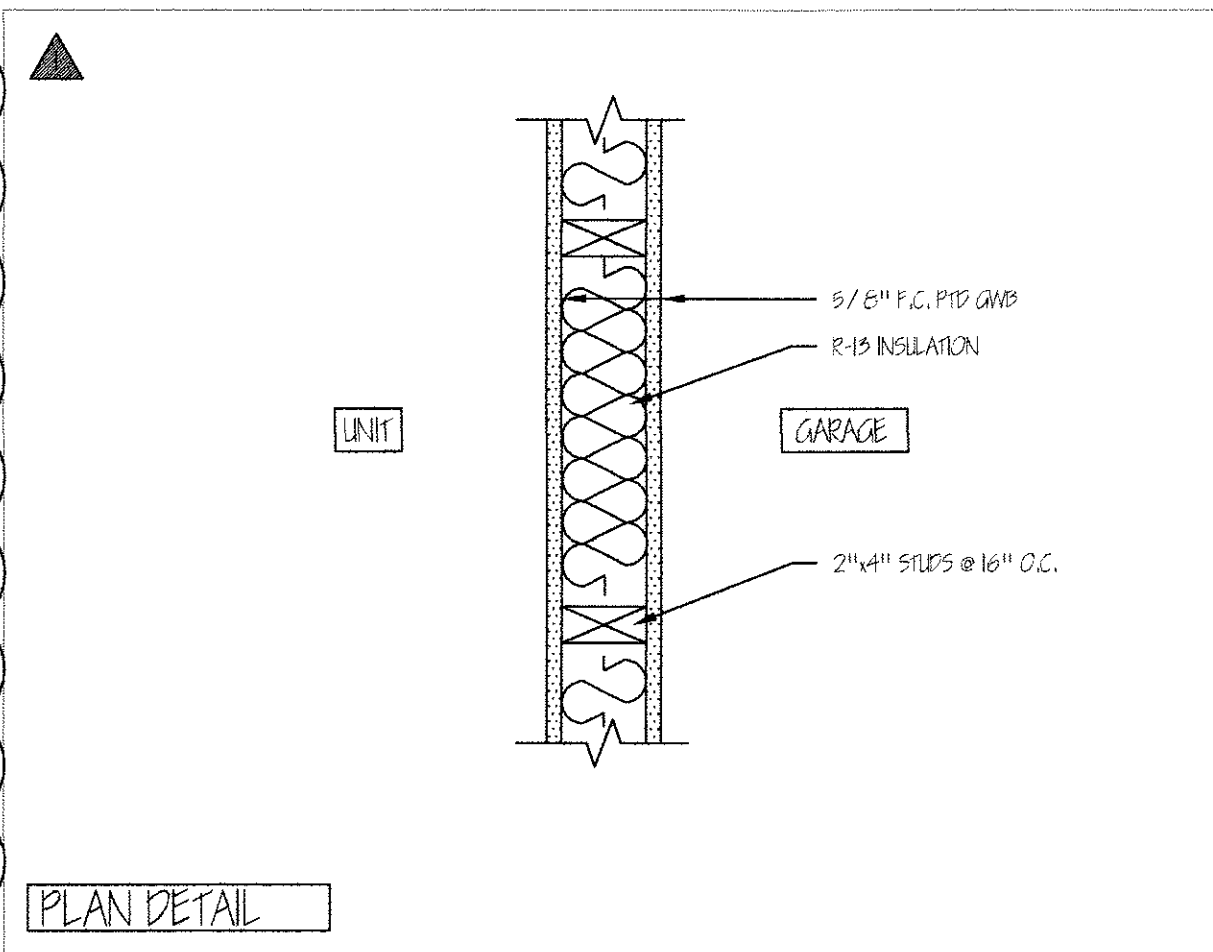

7 1 HR RATED WALL 1 1/2"=1'-0"

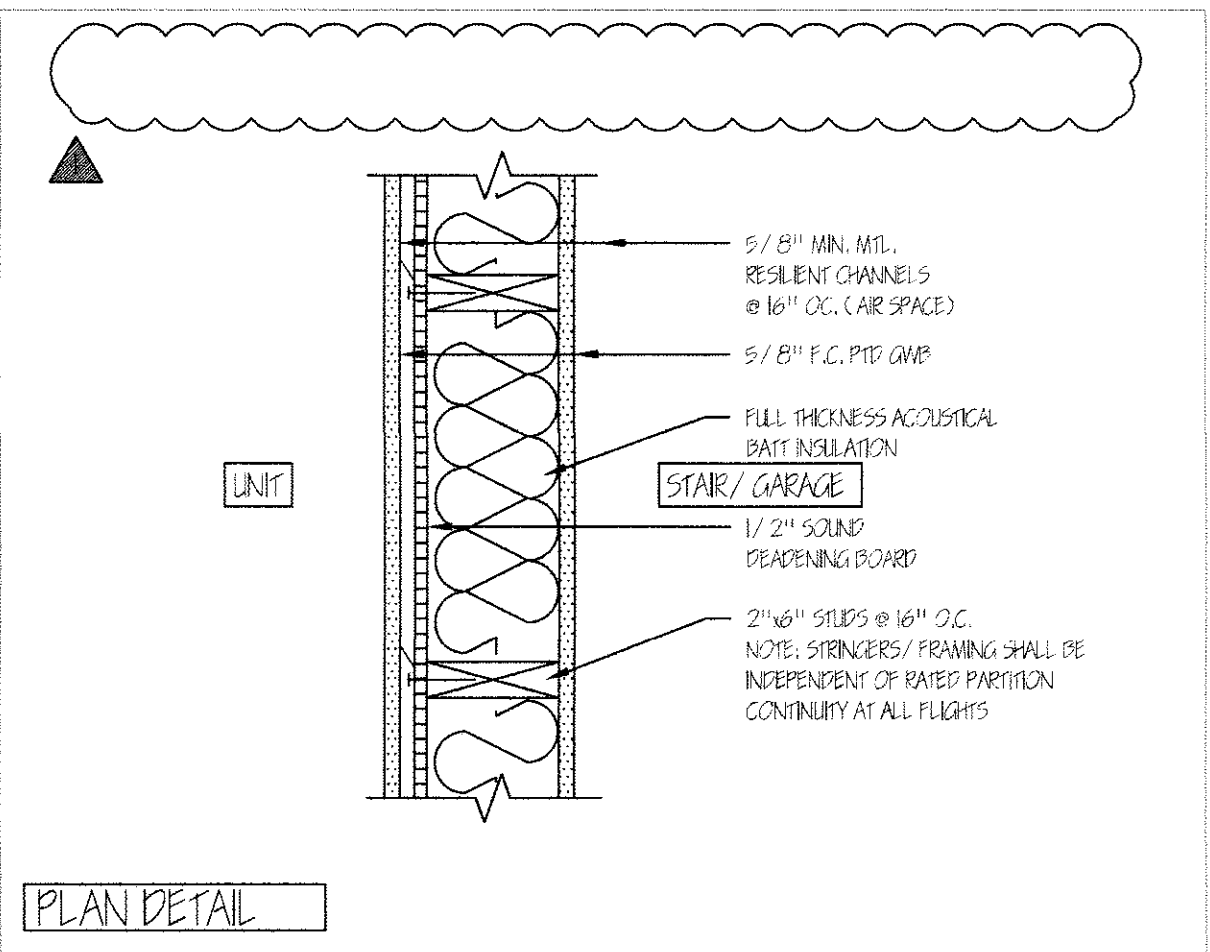

8 1 HR RATED PARTITION AT STAIR/GARAGE 1 1/2"=1'-0"

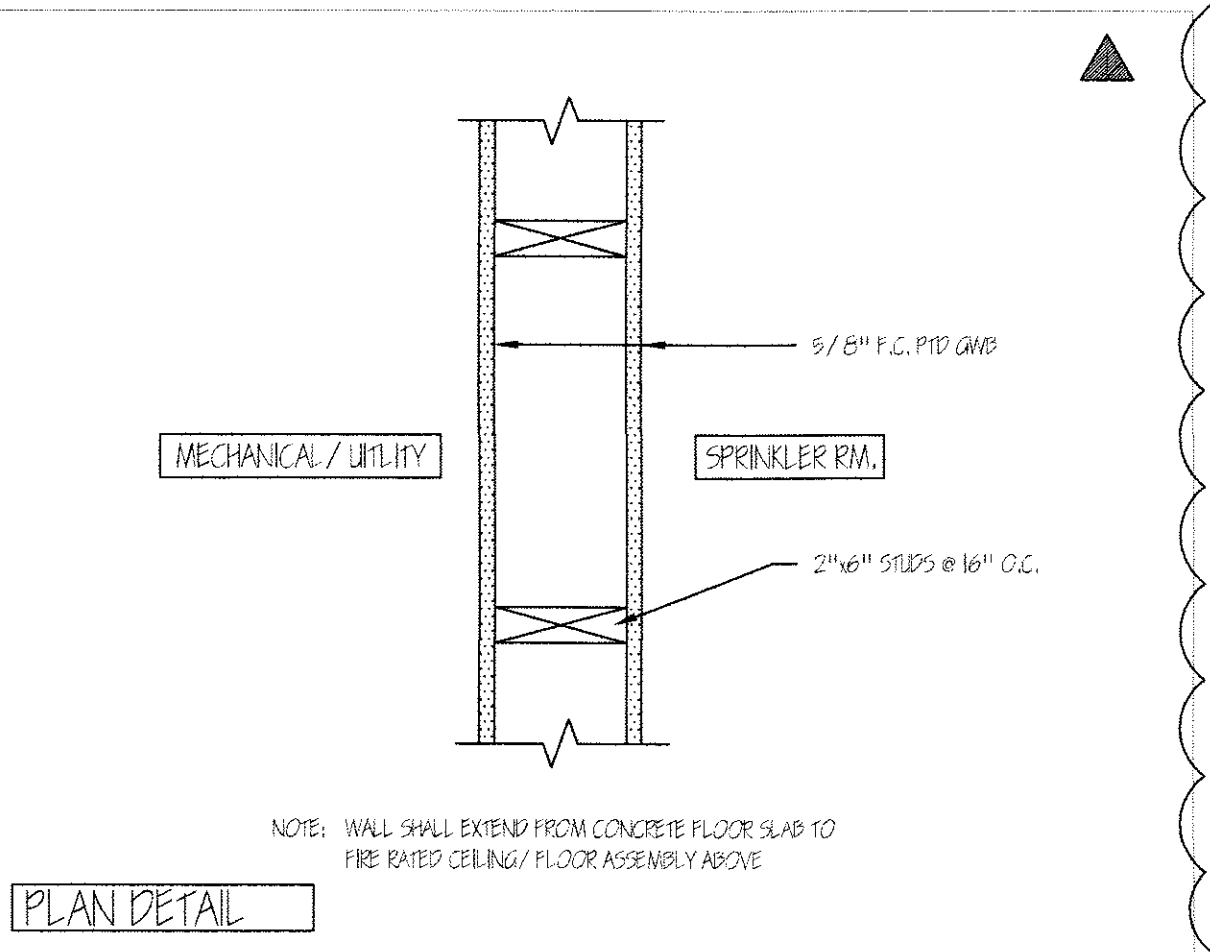

9 1 HR RATED PARTITION AT SPRINKLER ROOM 1 1/2"=1'-0"

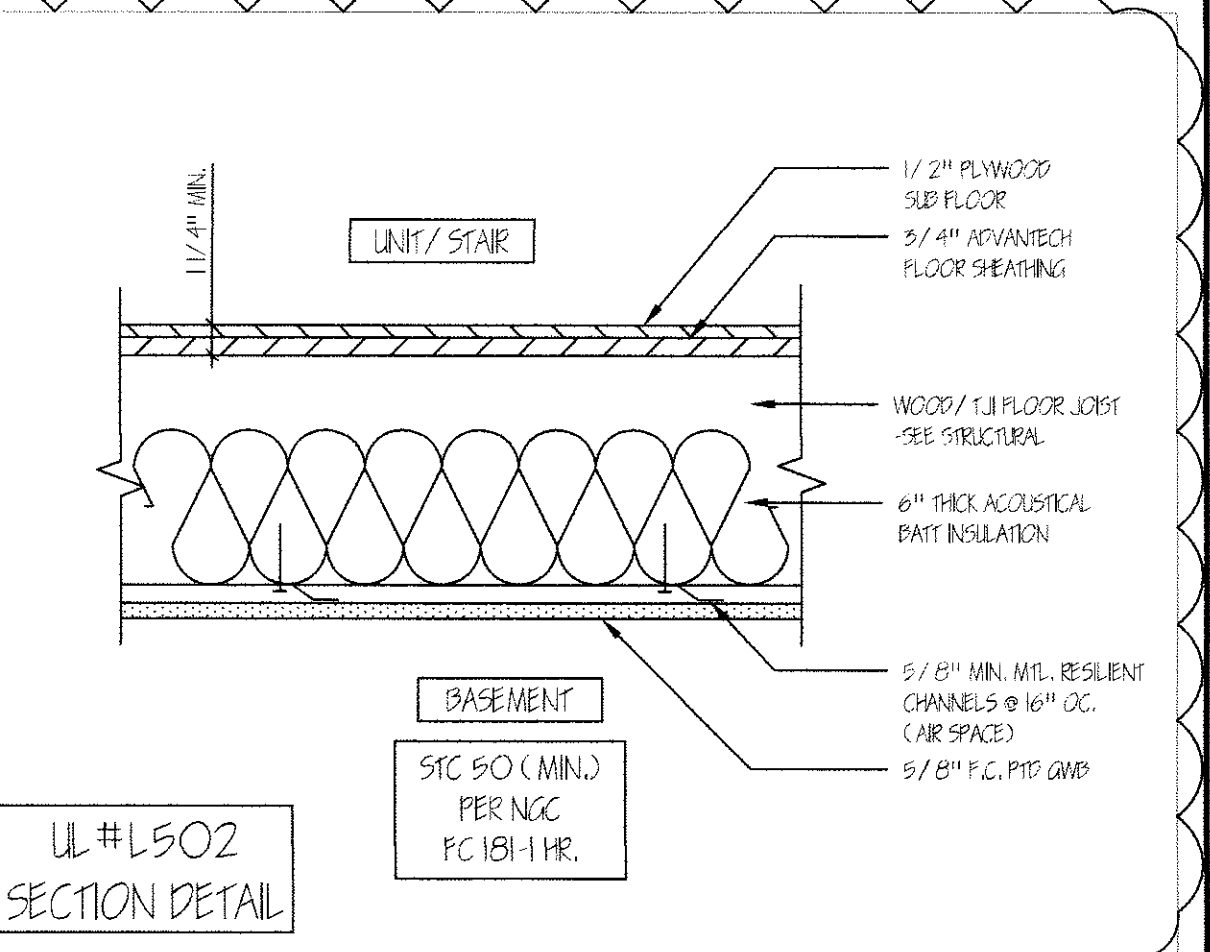

10 1 HR RATED FIRST FLOOR ASSEMBLY 1 1/2"=1'-0"

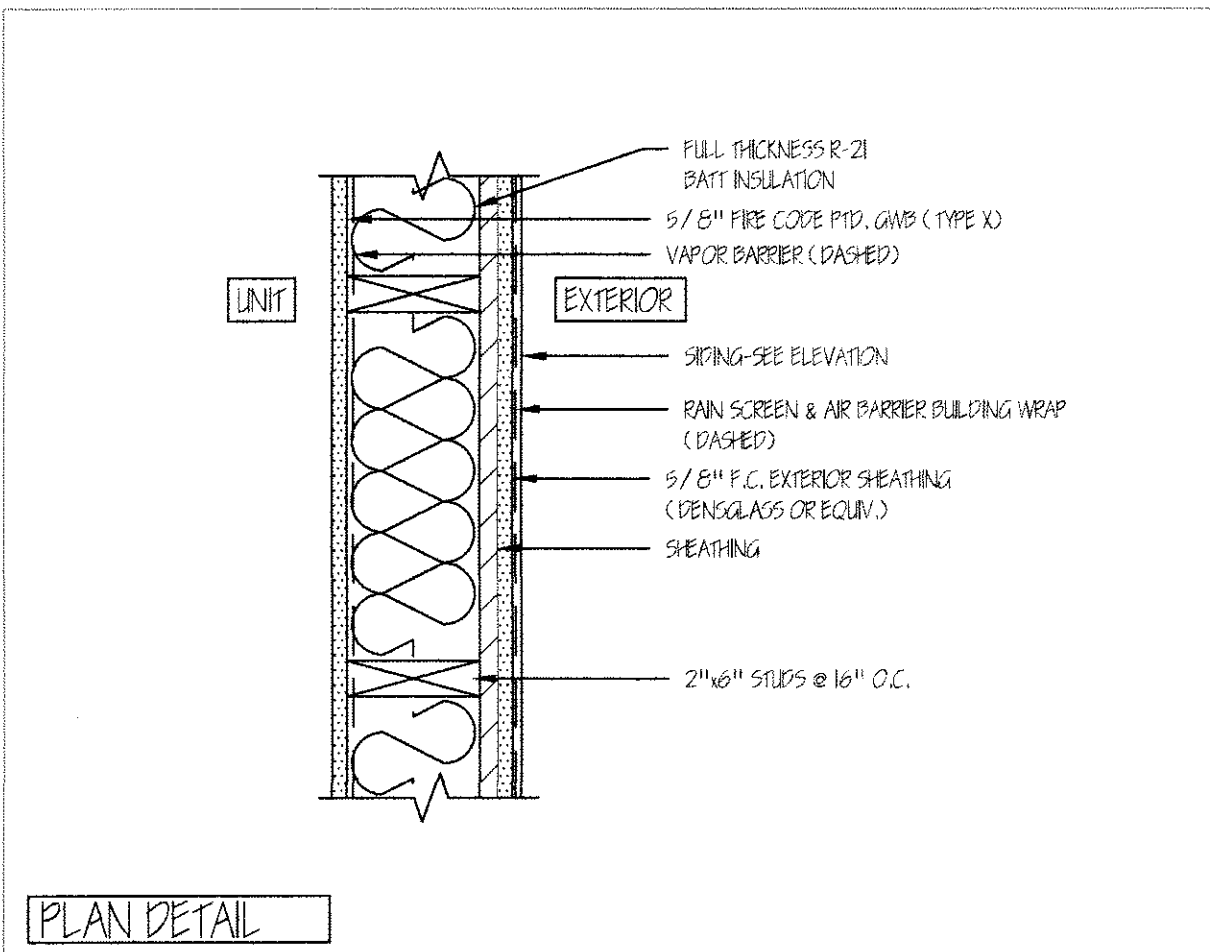

11 1 HR RATED EXTERIOR WALL ASSEMBLY 1 1/2"=1'-0"

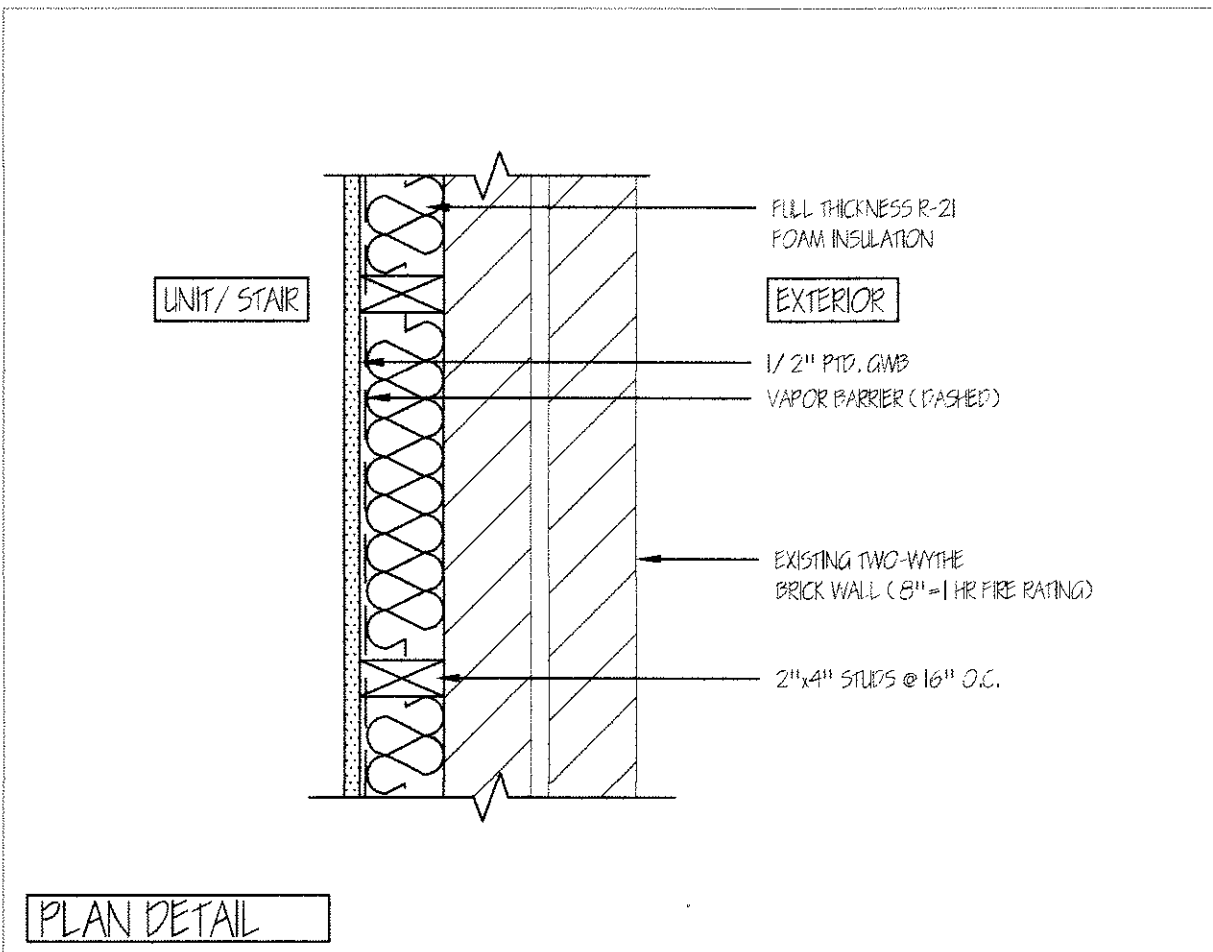

12 EXTERIOR WALL @ 1 HR MASONRY (8" BRICK) 1 1/2"=1'-0"

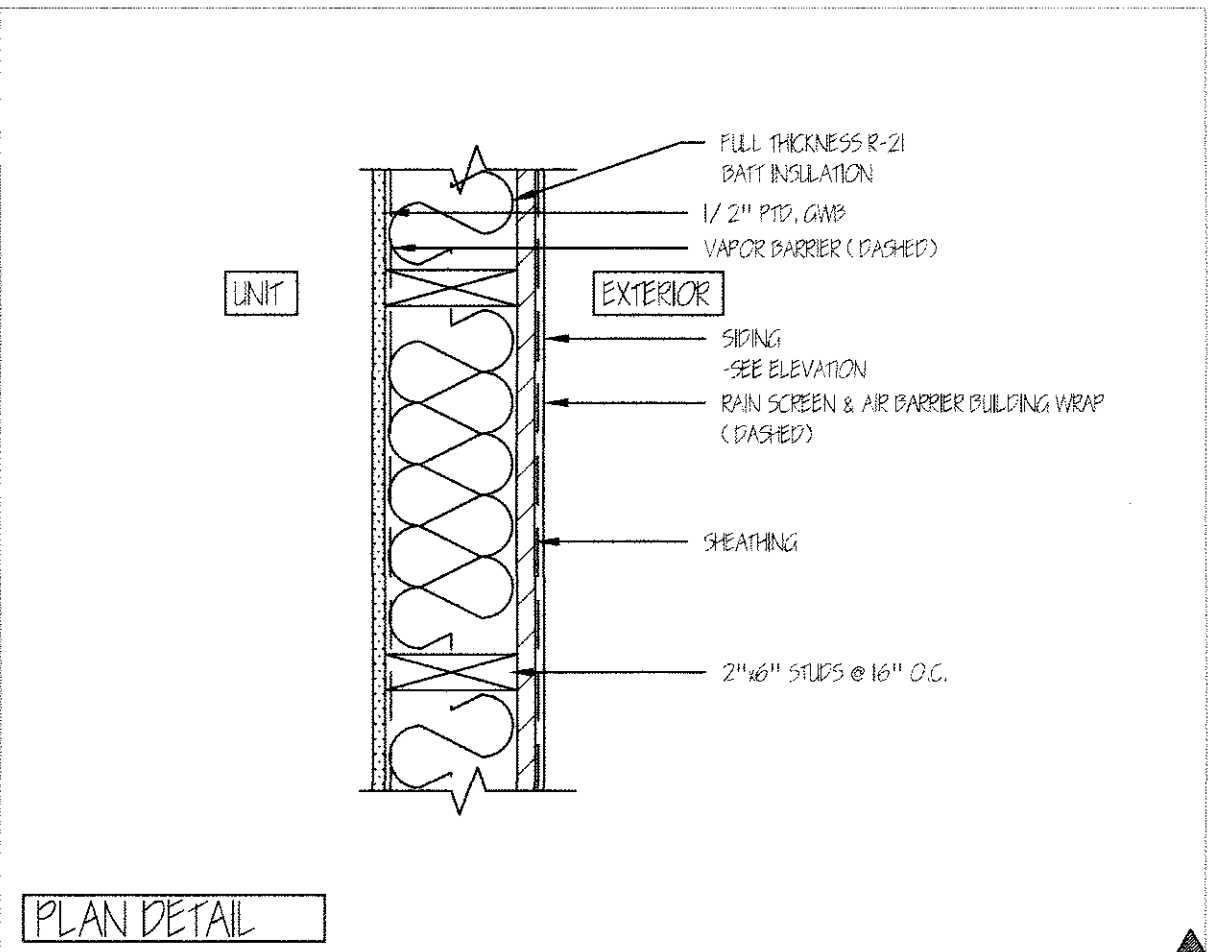

13 TYPICAL EXTERIOR WALL (NON-RATED) 1 1/2"=1'-0"

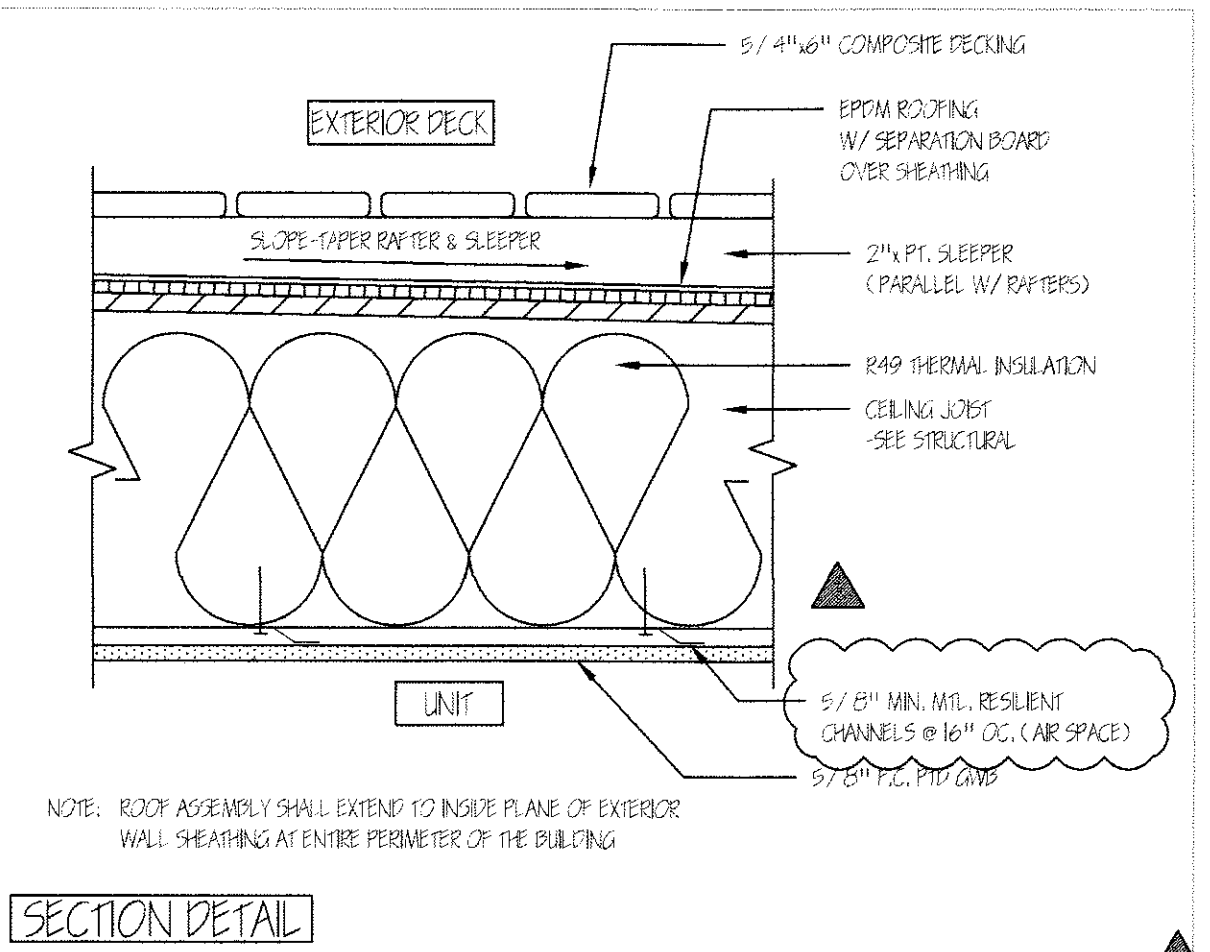

14 1 HR RATED CEILING/ROOF/DECK ASSEMBLY 1 1/2"=1'-0"

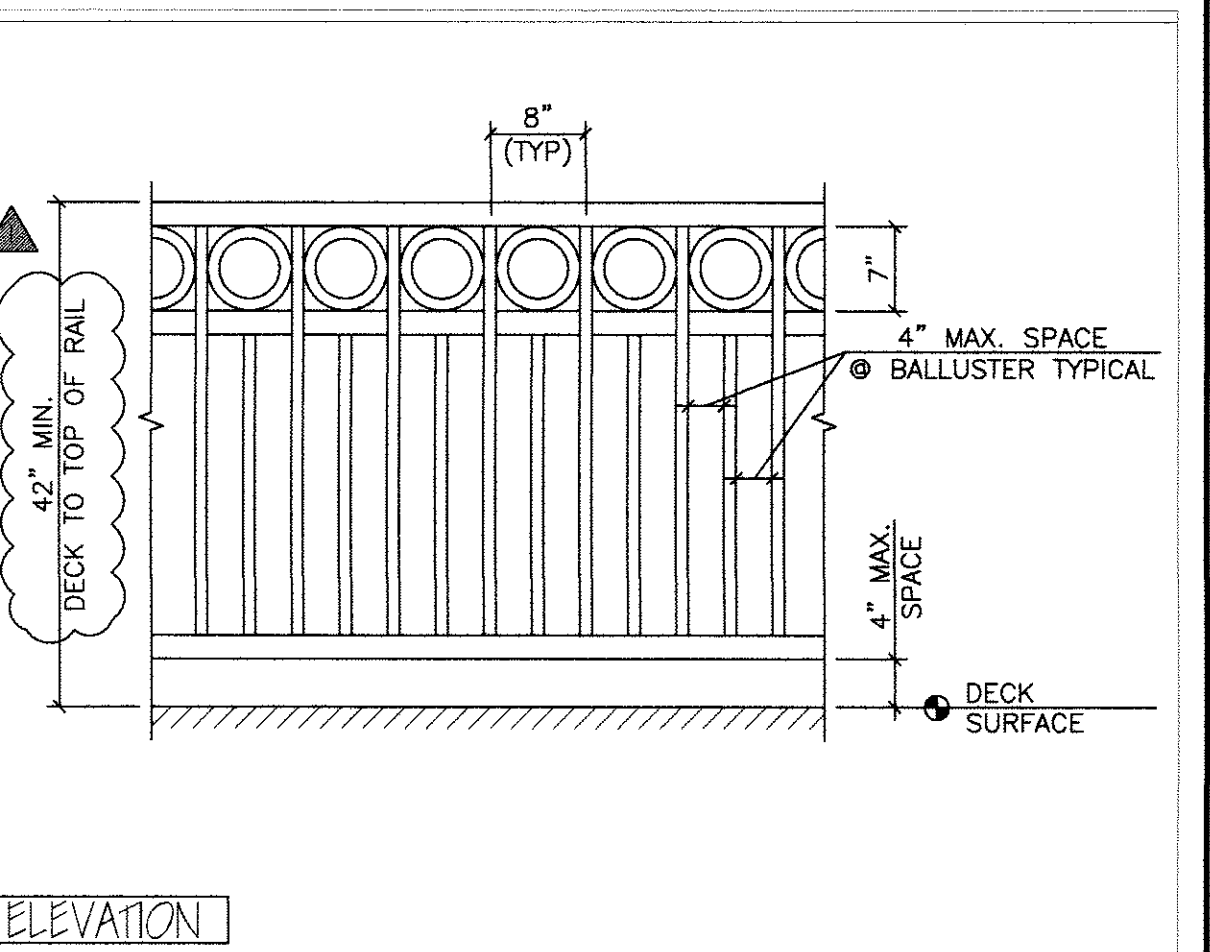

15 TYPICAL DECK GUARDRAIL 3/4"=1'-0"

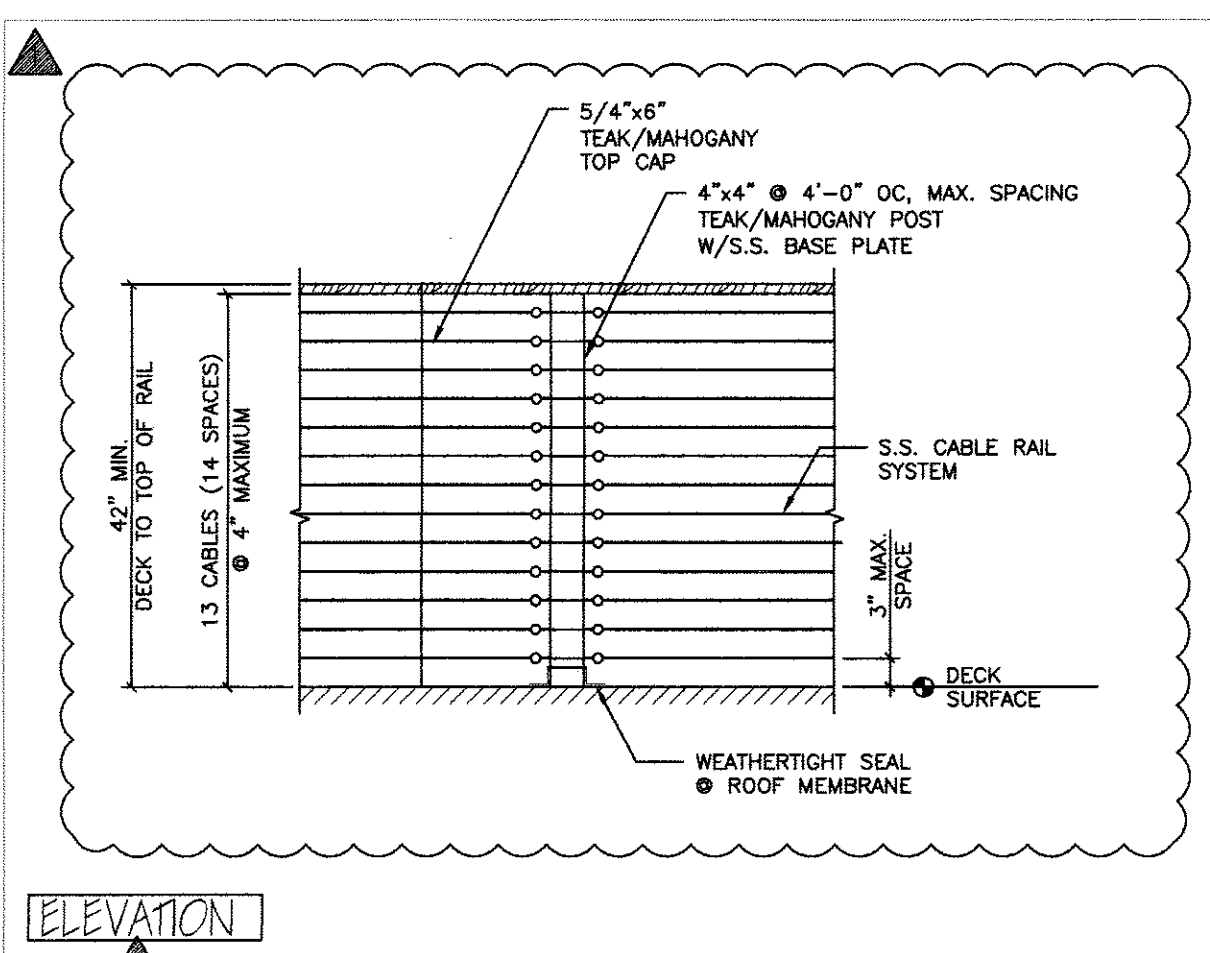

16 TYPICAL CABLERAIL DECK GUARDRAIL 3/4"=1'-0"

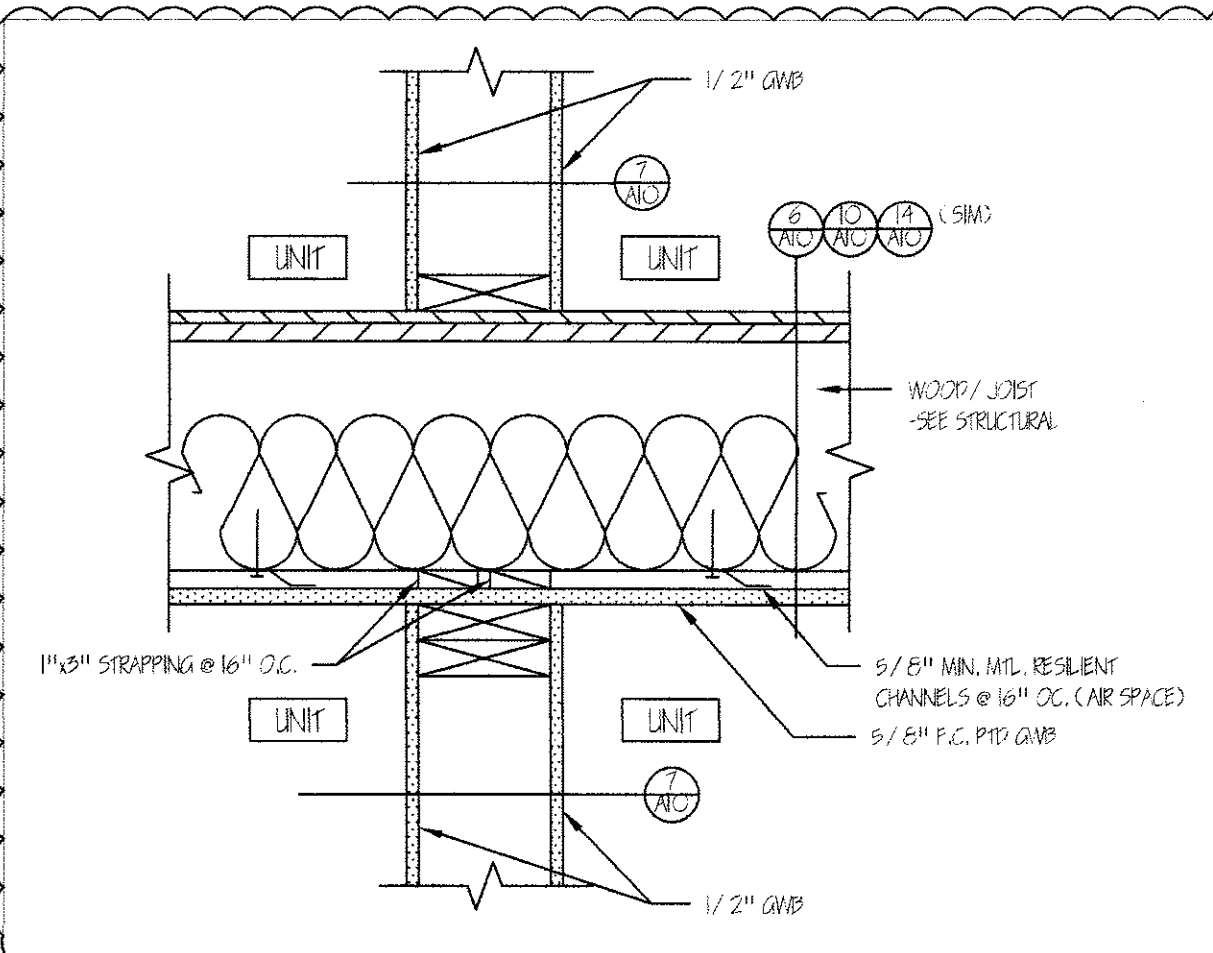

17 NON-RATED PARTITION @ 1 HR. FIRE RATED FLOOR/CEILING ASSEMBLY 1 1/2"=1'-0"

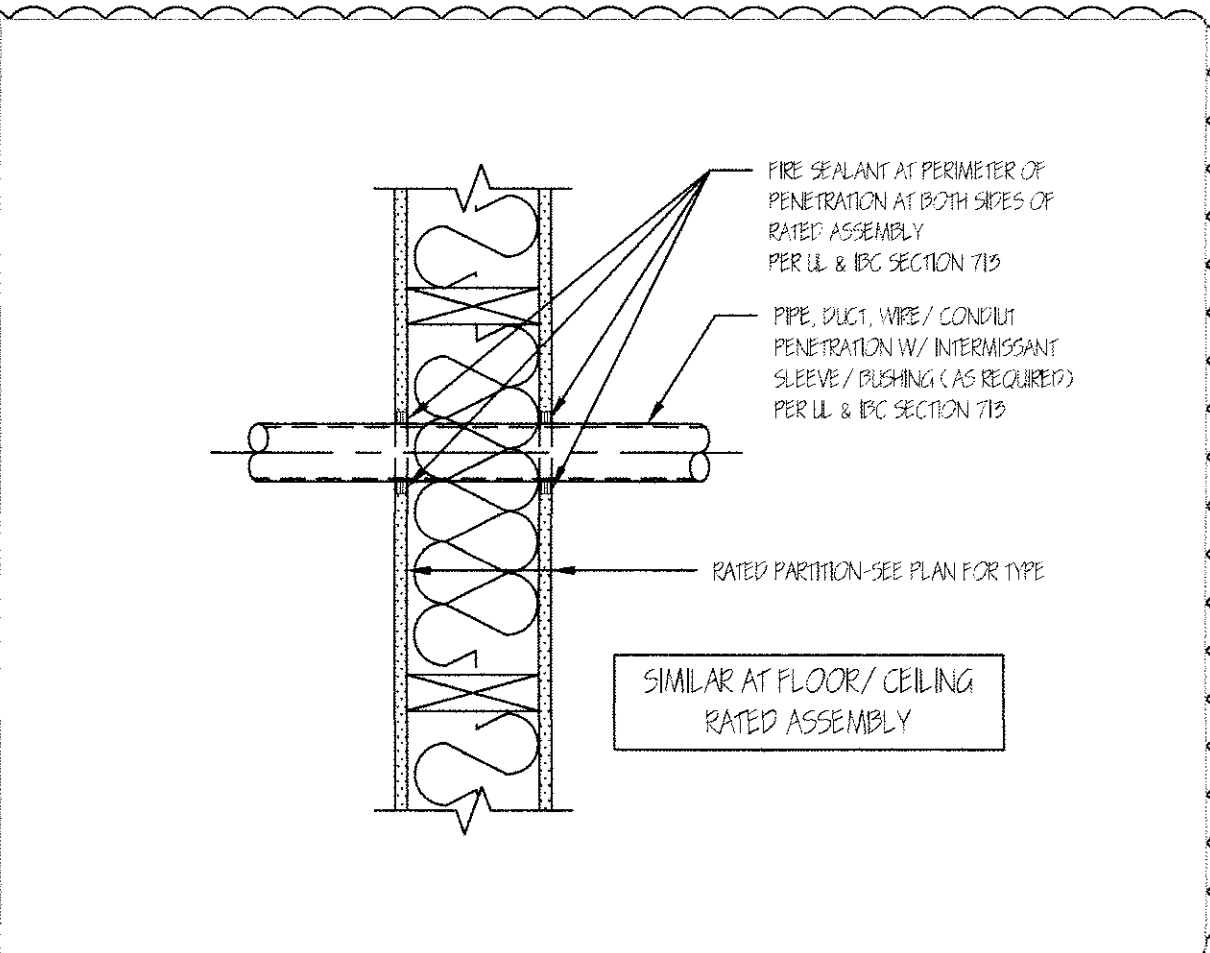

18 FIRE SEALANT @ PENETRATIONS 1 1/2"=1'-0"