

1 INTERIOR STAIR RISER/TREAD DETAIL 1 1/2"=1'-0"

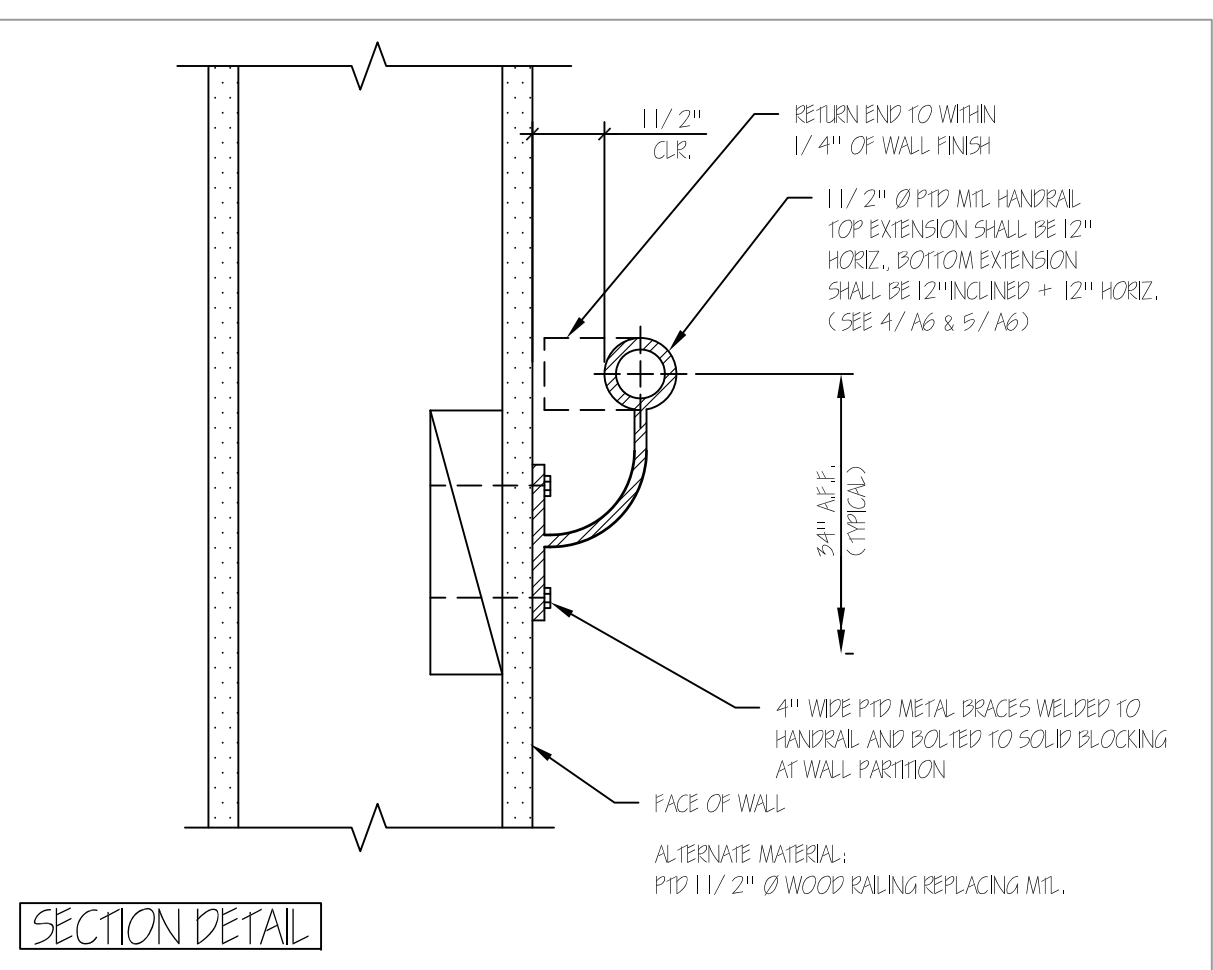

2 TYPICAL WALL HANDRAIL SECTION 3/4"=1'-0"

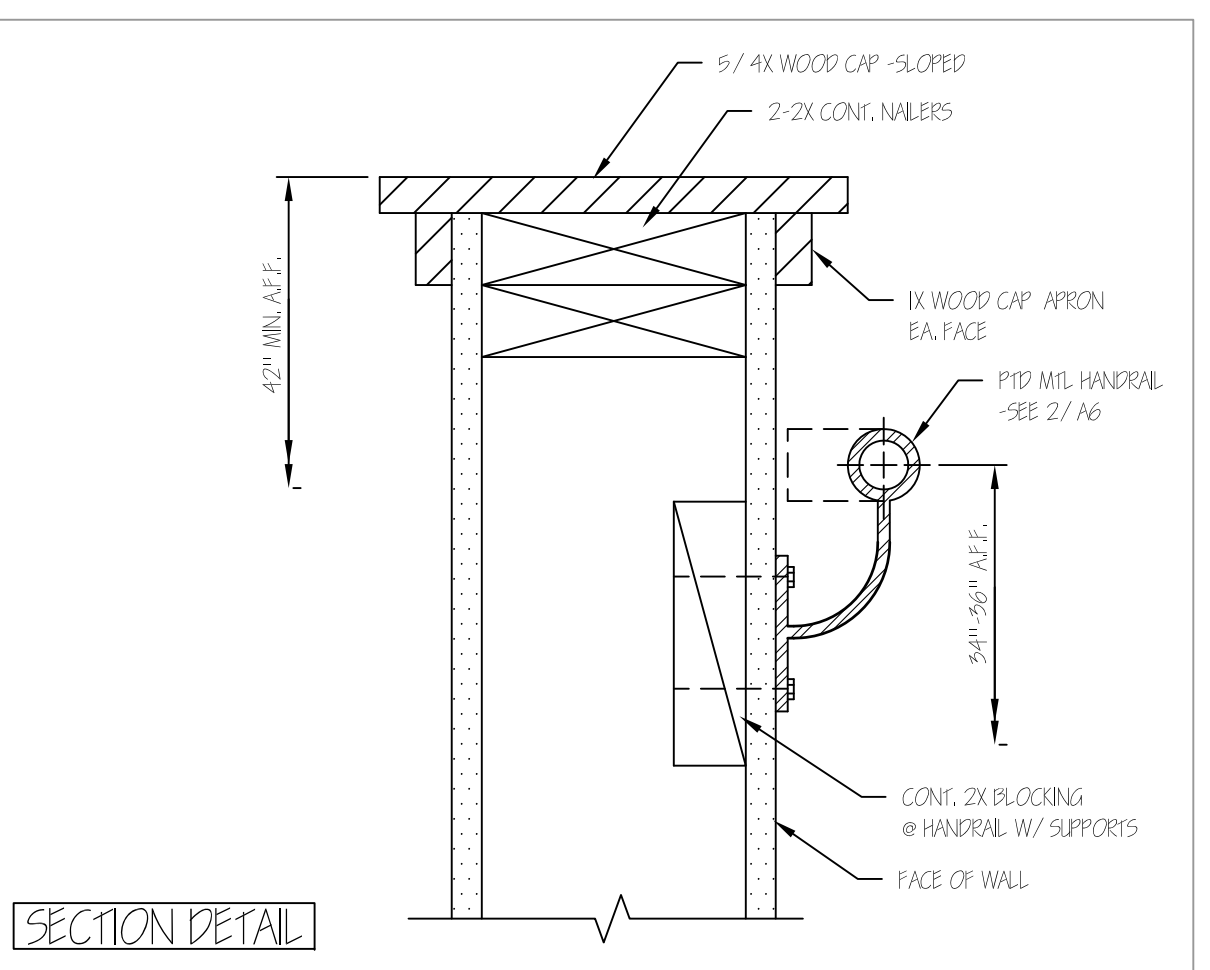

3 STAIR GUARDRAIL 3/4"=1'-0"

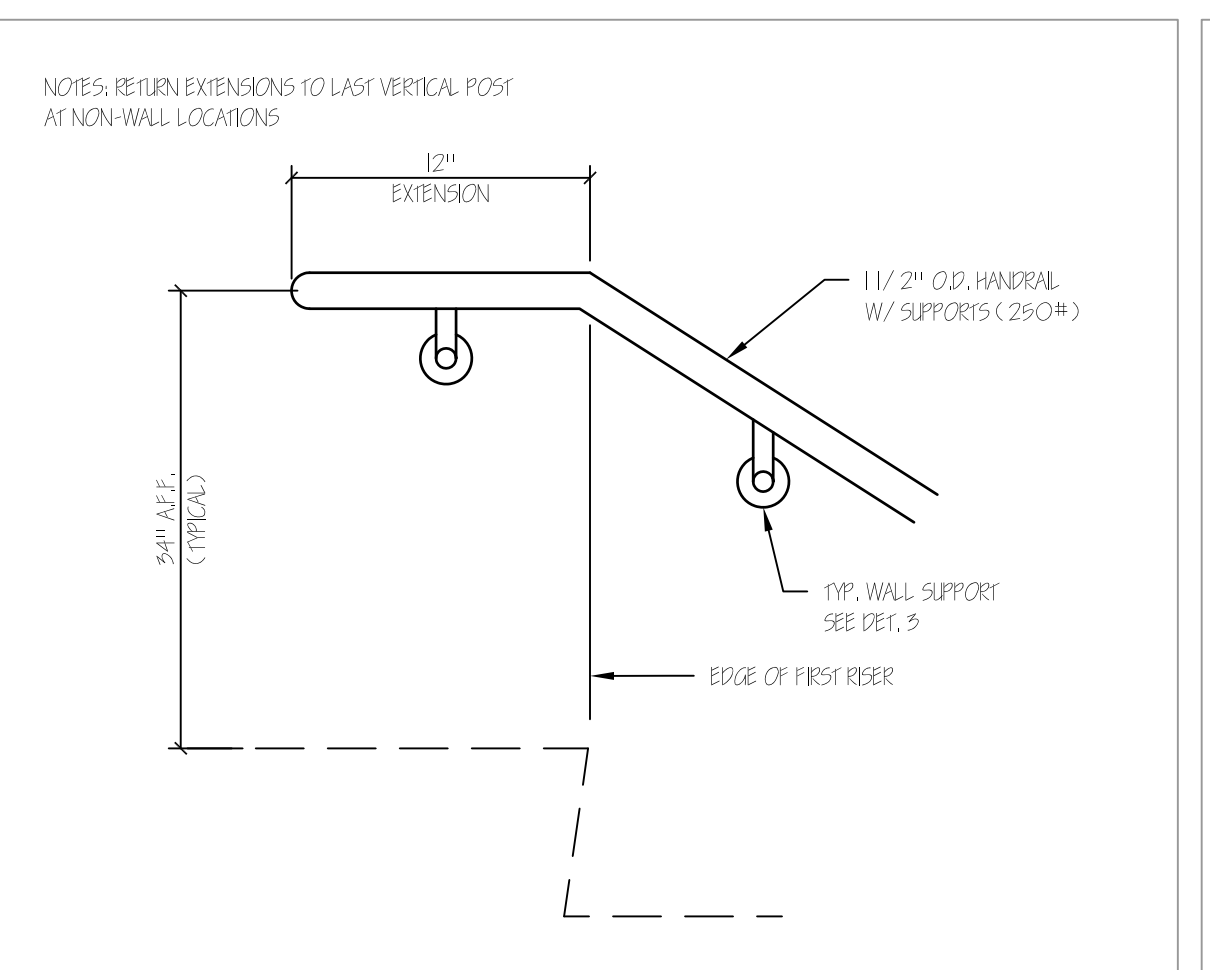

4 TYPICAL WALL HANDRAIL-TOP 3/4"=1'-0"

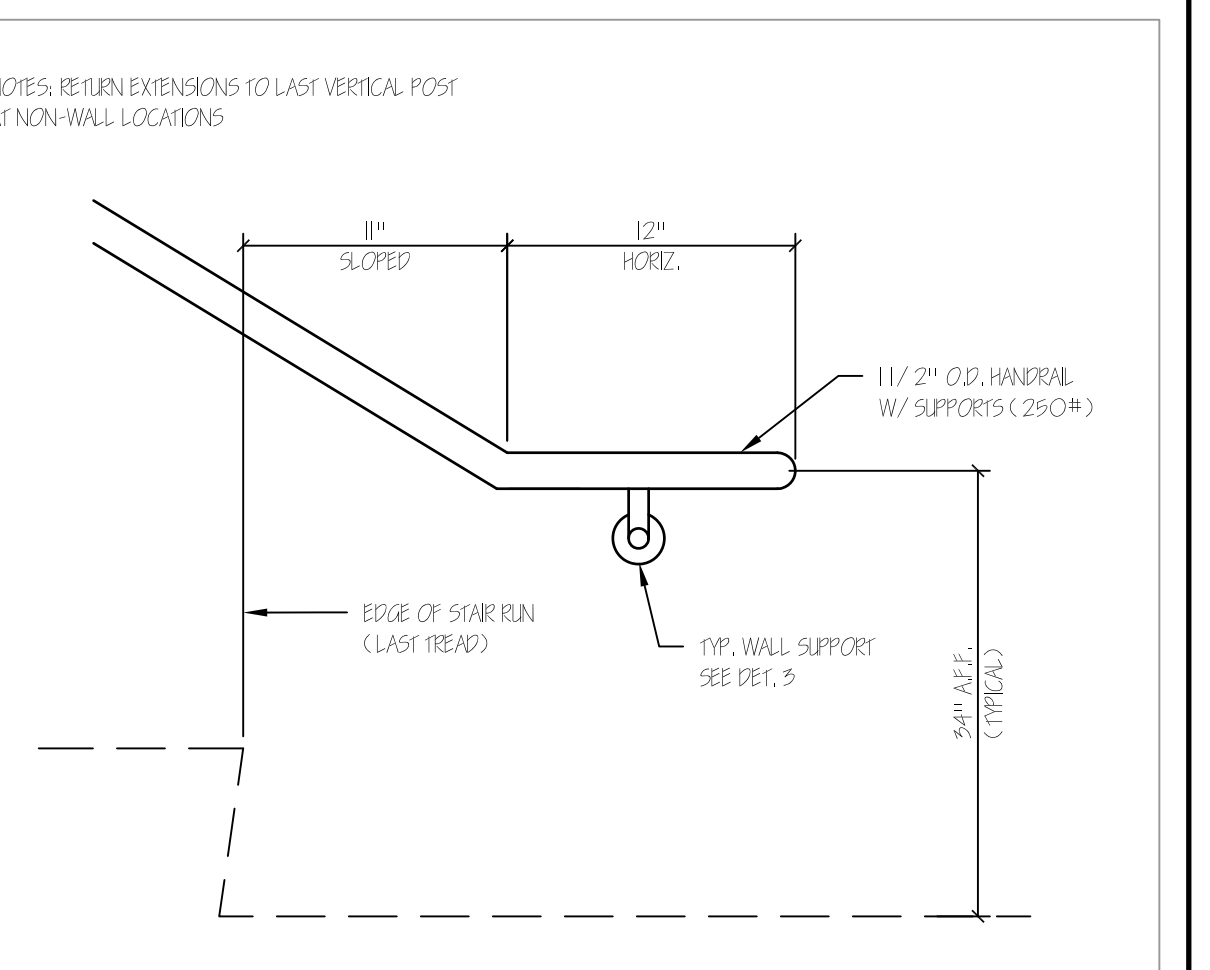

5 TYPICAL WALL HANDRAIL-BOTTOM 3/4"=1'-0"

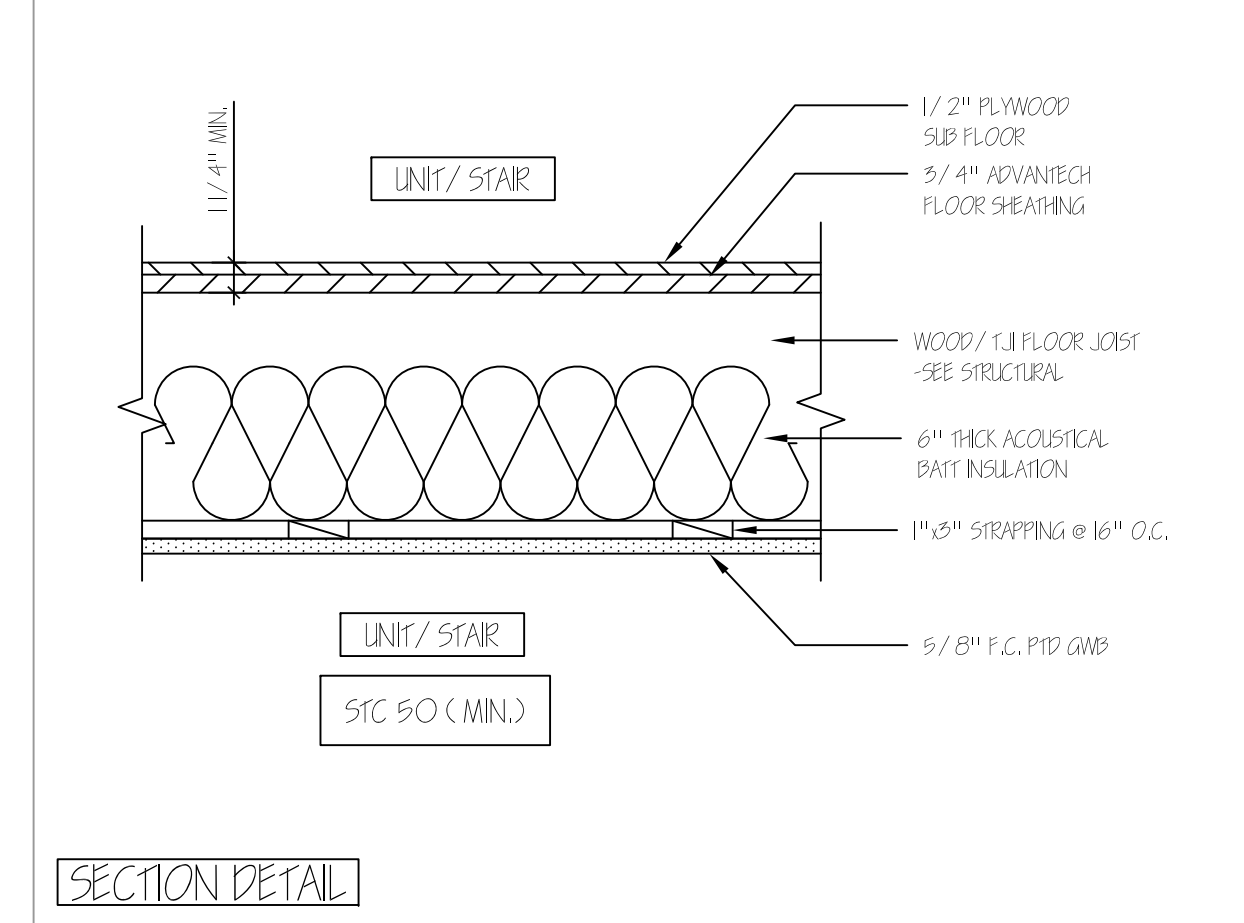

6 1 HR RATED FLOOR/CEILING ASSEMBLY 1 1/2"=1'-0"

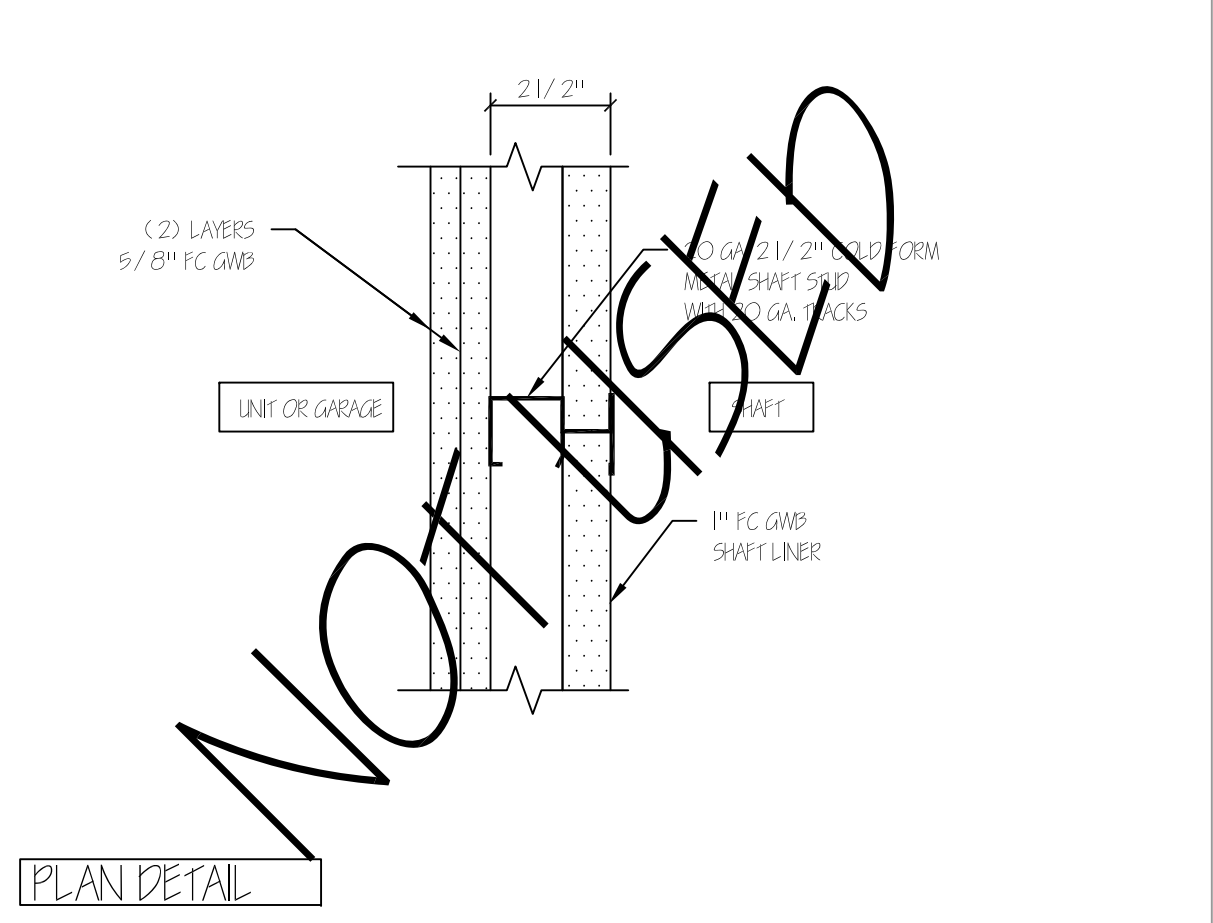

7 2 HR RATED SHAFT WALL 3/4"=1'-0"

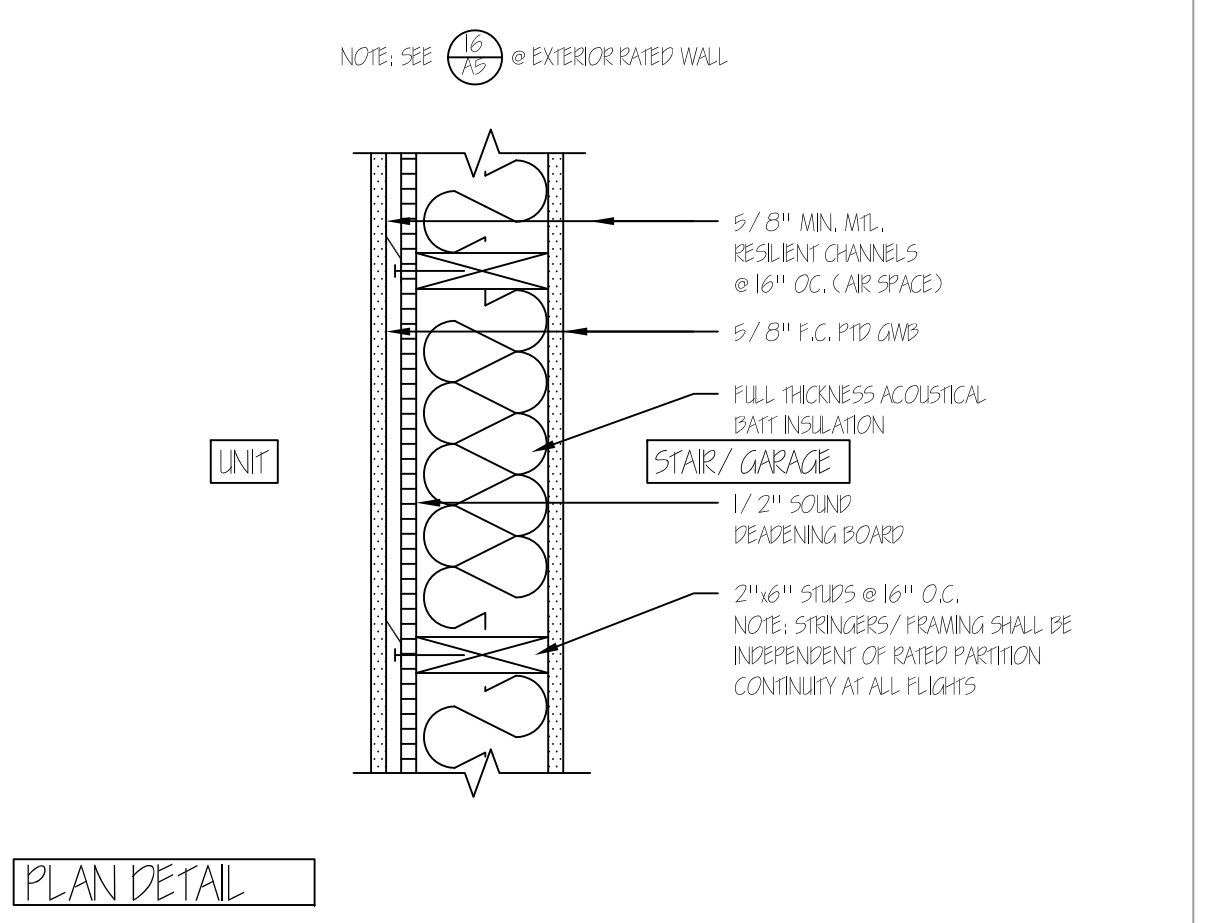

8 1 HR RATED PARTITION AT STAIR/GARAGE 1 1/2"=1'-0"

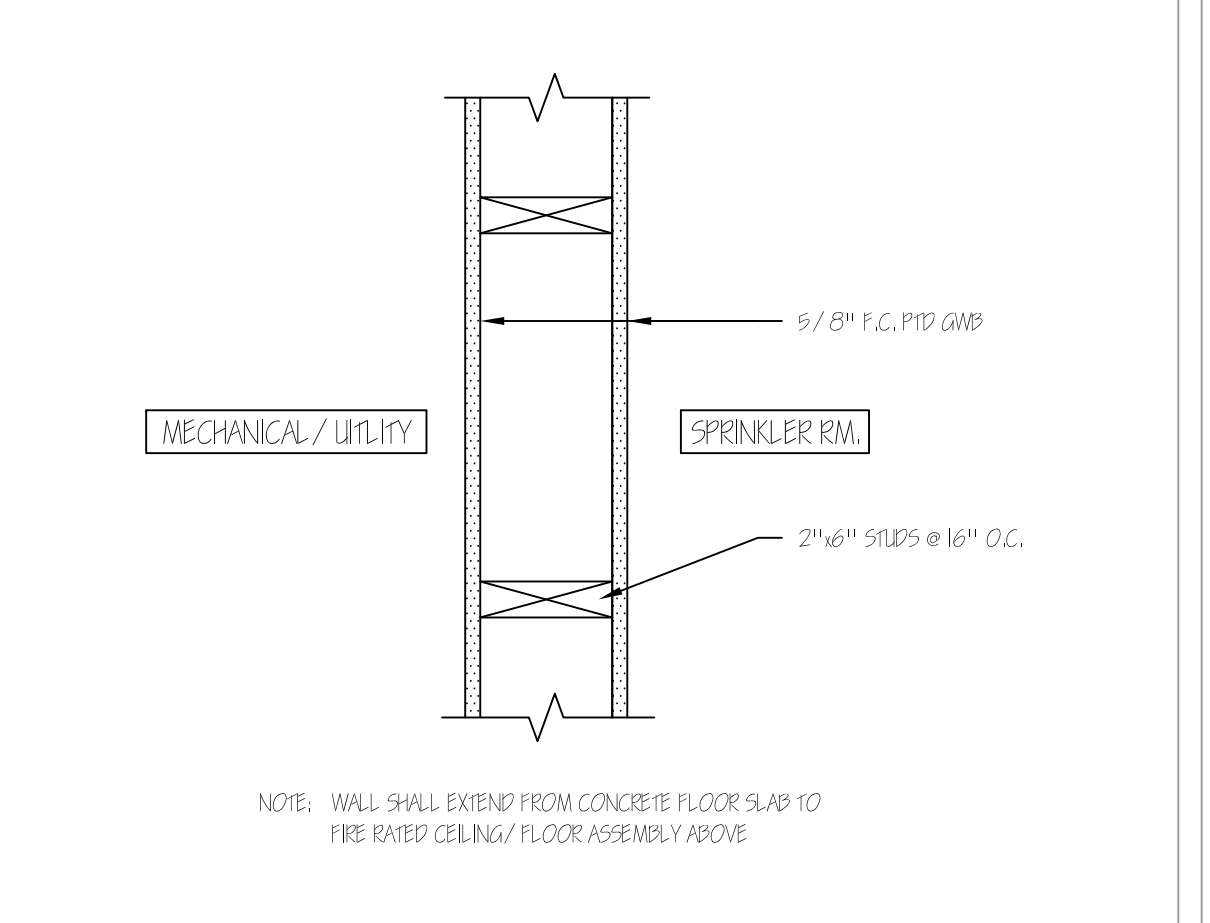

9 1 HR RATED PARTITION AT SPRINKLER ROOM 1 1/2"=1'-0"

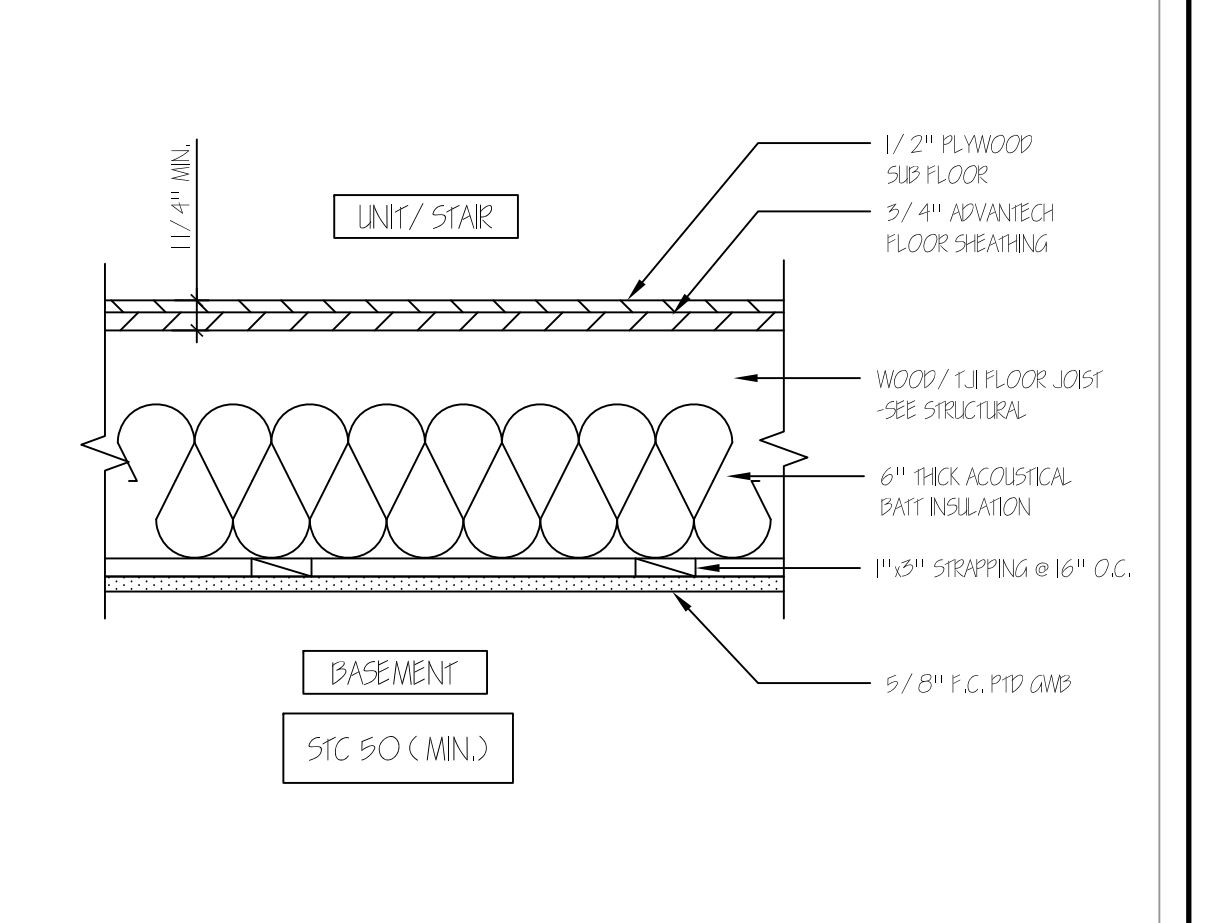

10 1 HR RATED FIRST FLOOR ASSEMBLY 1 1/2"=1'-0"

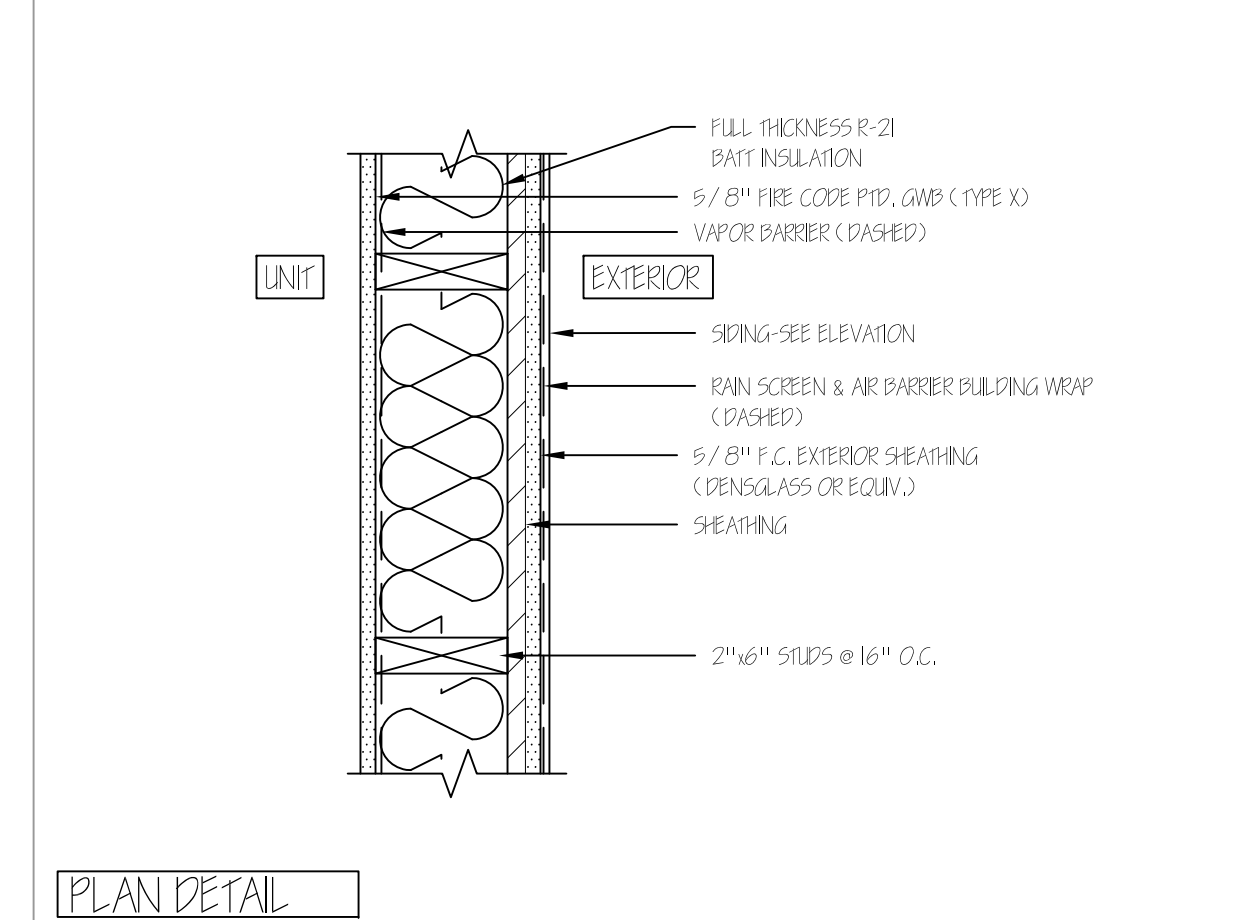

11 1 HR RATED EXTERIOR WALL ASSEMBLY 1 1/2"=1'-0"

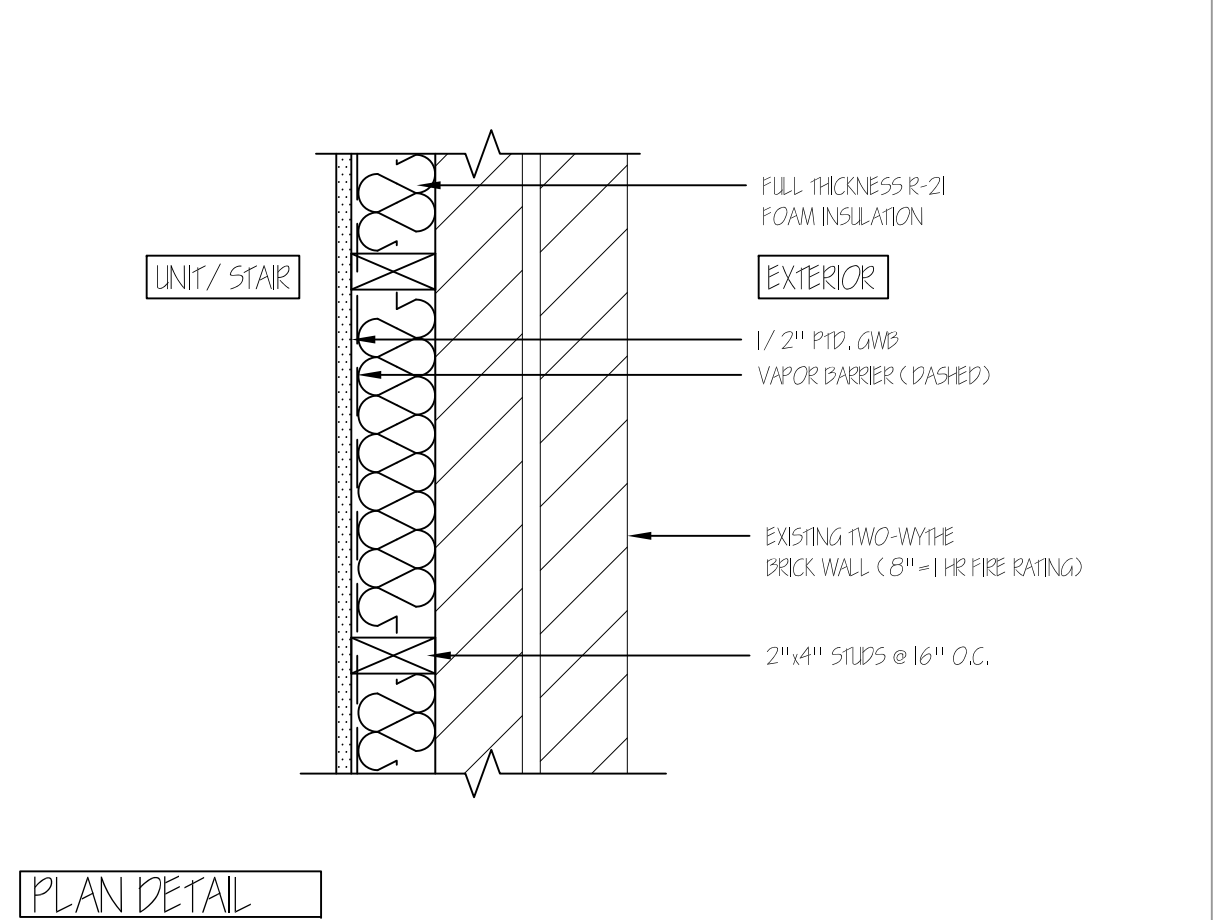

12 EXTERIOR WALL @ 1 HR MASONRY (8" BRICK) 1 1/2"=1'-0"

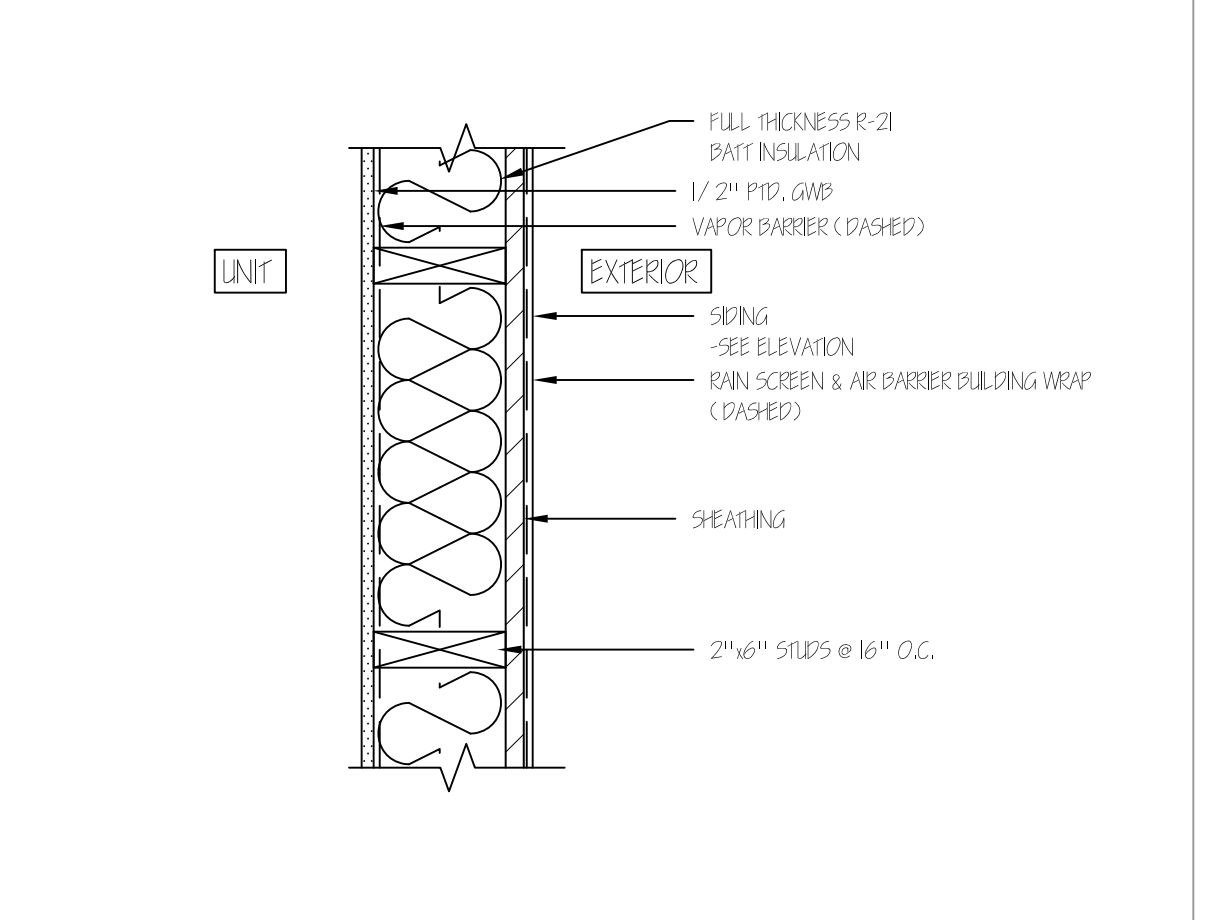

13 TYPICAL EXTERIOR WALL (NON-RATED) 1 1/2"=1'-0"

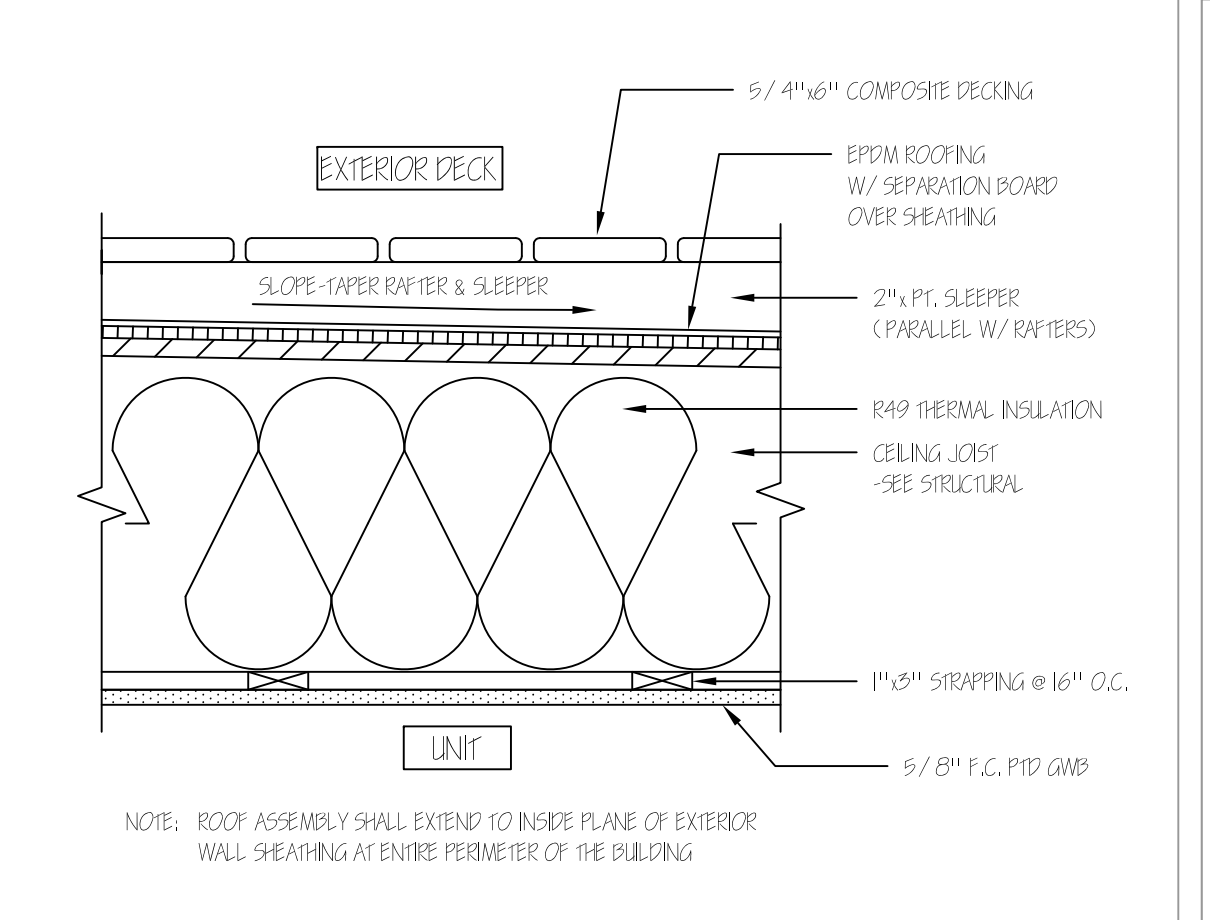

13 1 HR RATED CEILING/ROOF/DECK ASSEMBLY 1 1/2"=1'-0"

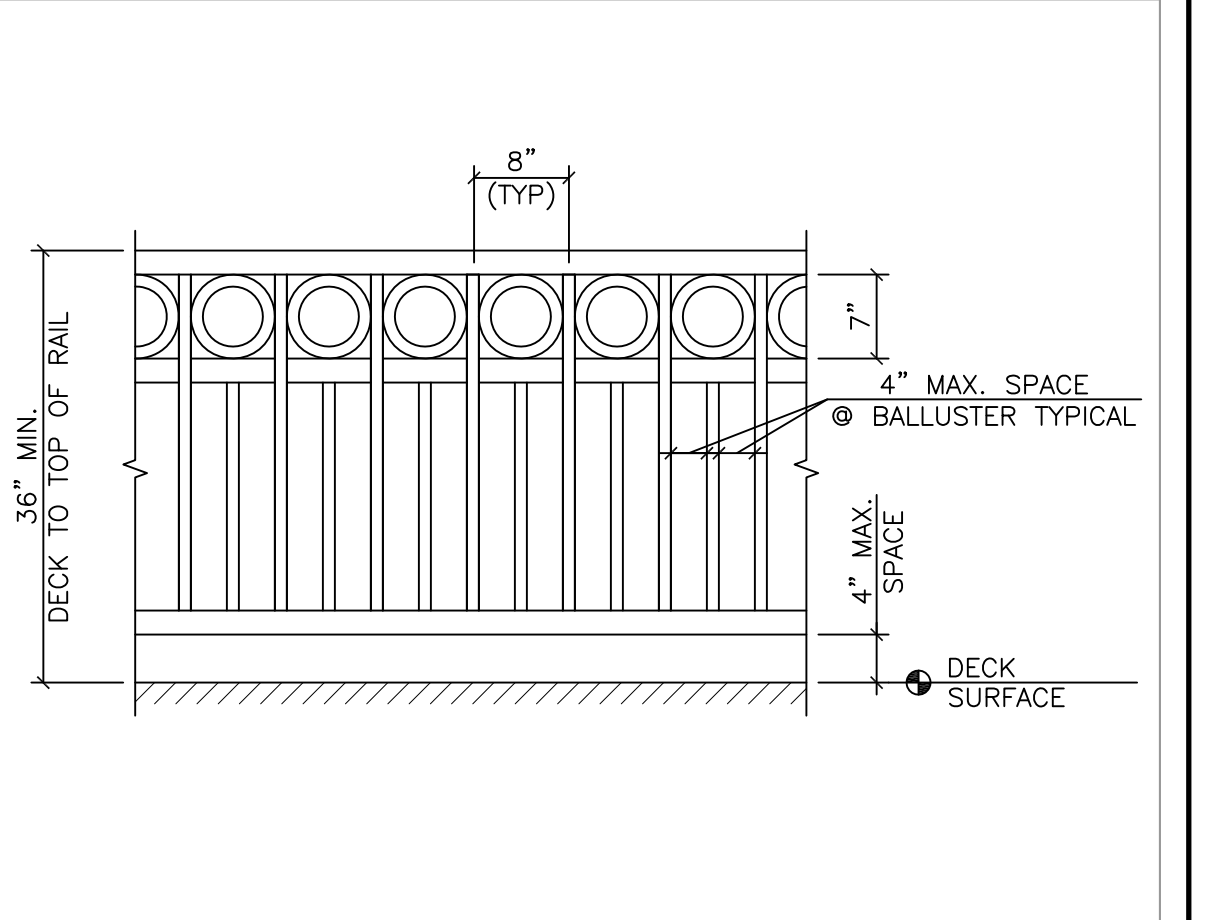

14 TYPICAL DECK GUARDRAIL 3/4"=1'-0"

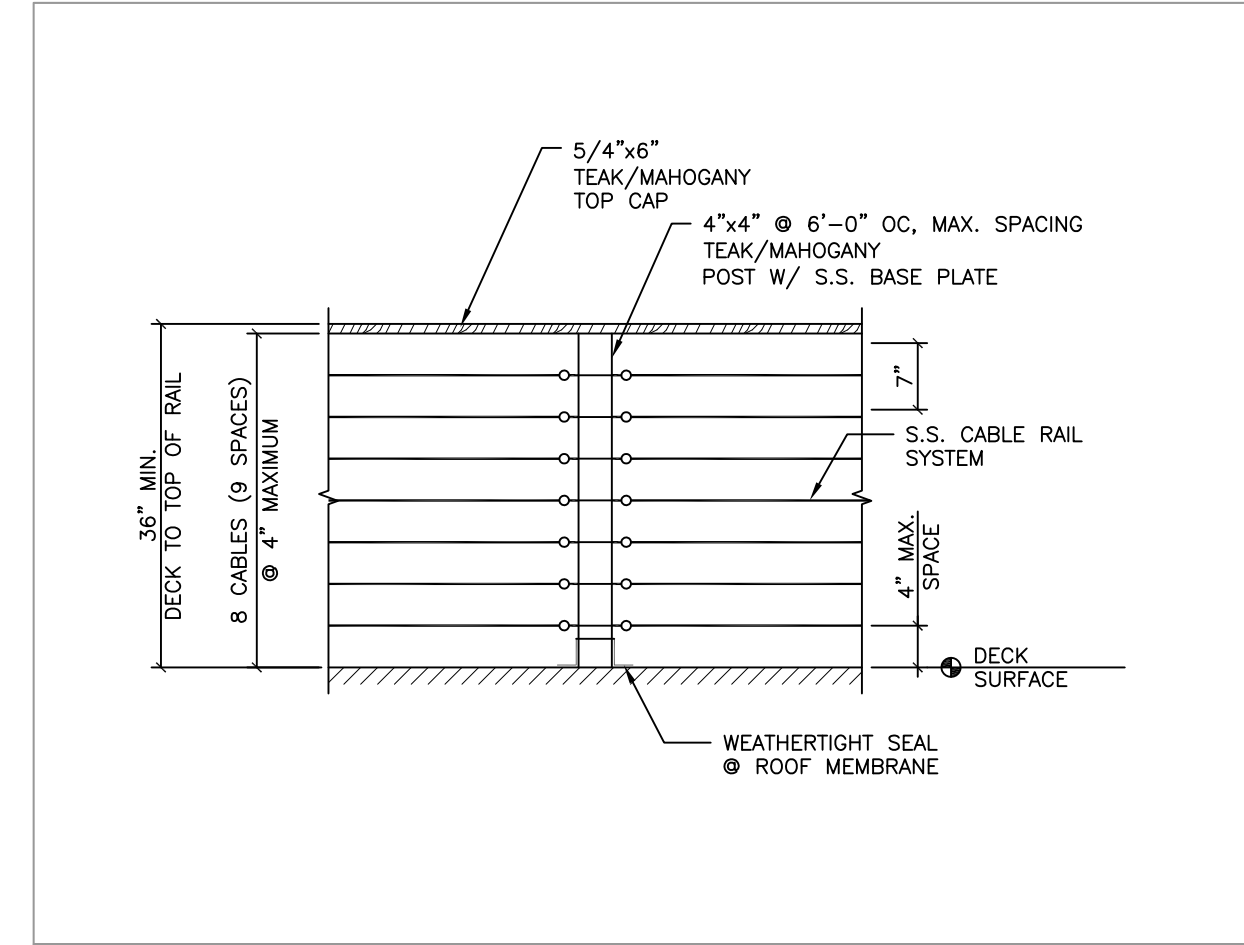

14 TYPICAL CABLERAIL DECK GUARDRAIL 3/4"=1'-0"

