

1 ENTRY CLOSET - SOUTH  
 $\frac{1}{2}'' = 1'-0''$

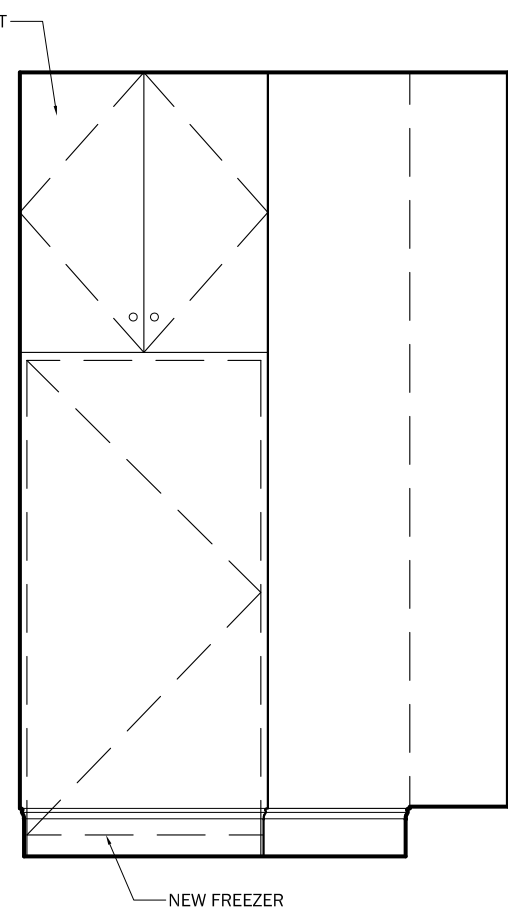

2 ENTRY CLOSET - WEST  
 $\frac{1}{2}'' = 1'-0''$

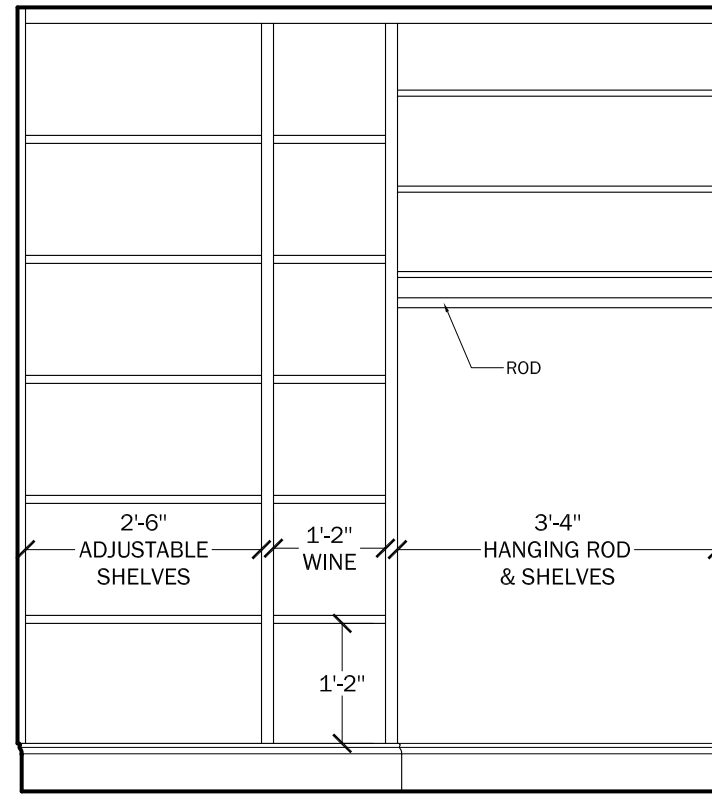

3 ENTRY CLOSET - NORTH  
 $\frac{1}{2}'' = 1'-0''$

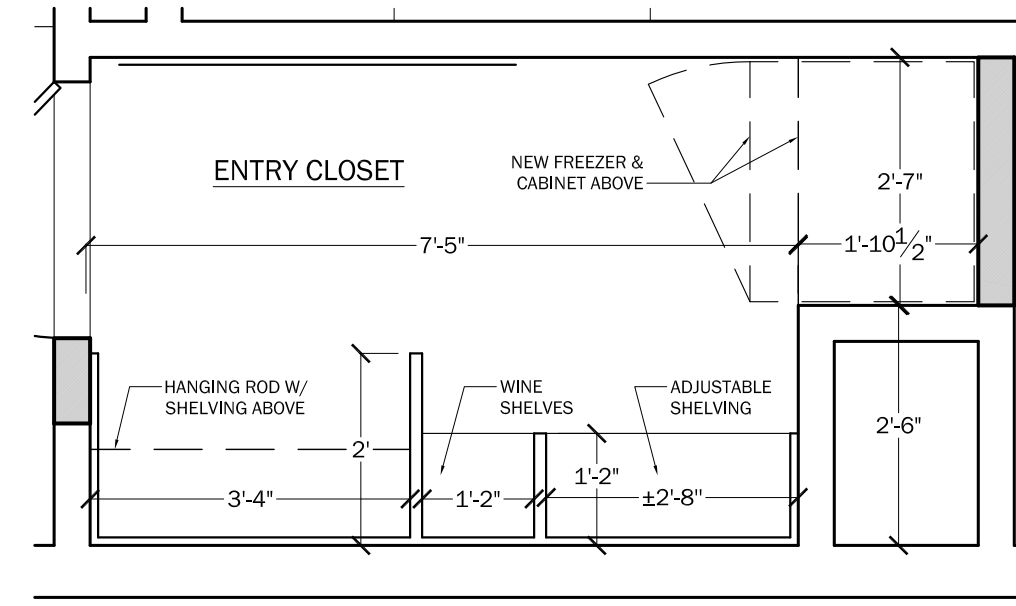

4 ENLARGED PLAN - ENTRY CLOSET  
 $\frac{1}{2}'' = 1'-0''$

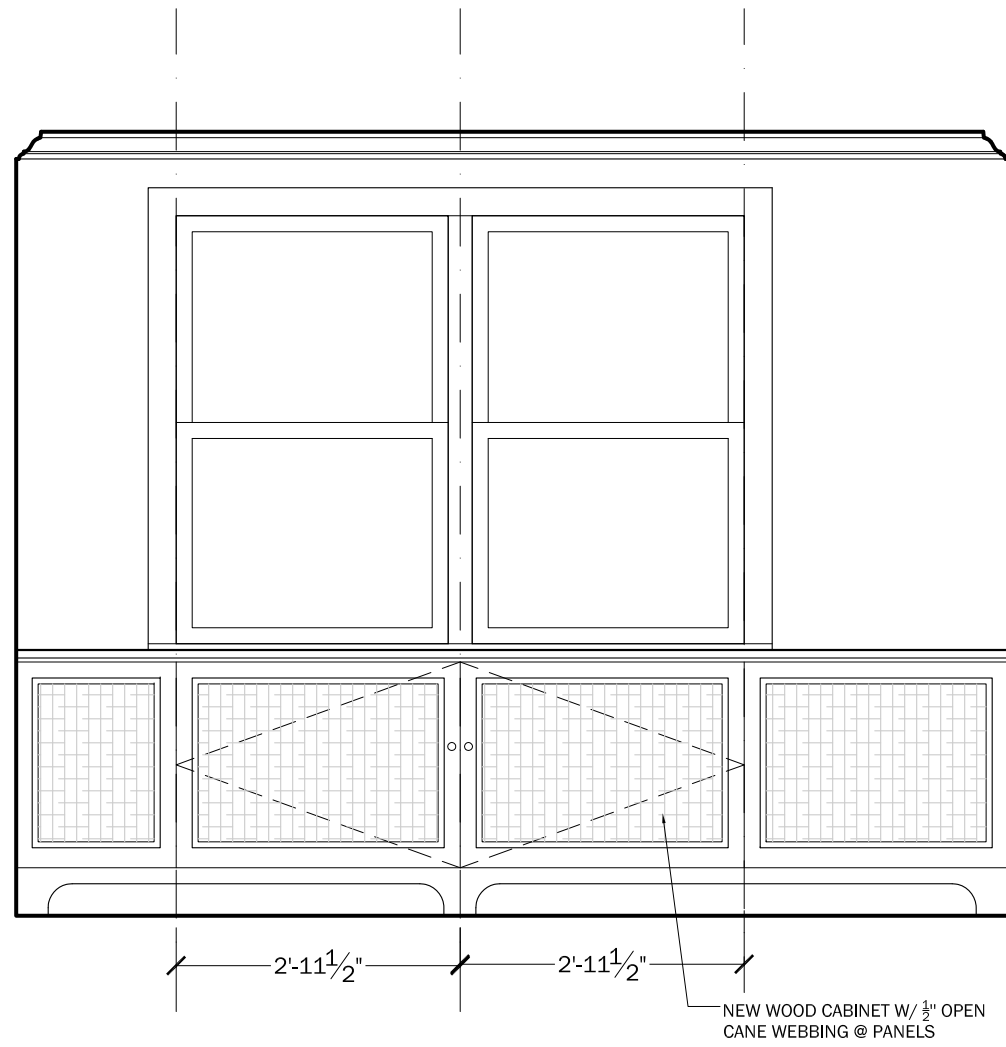

5 DINING ROOM - SOUTH  
 $\frac{1}{2}'' = 1'-0''$

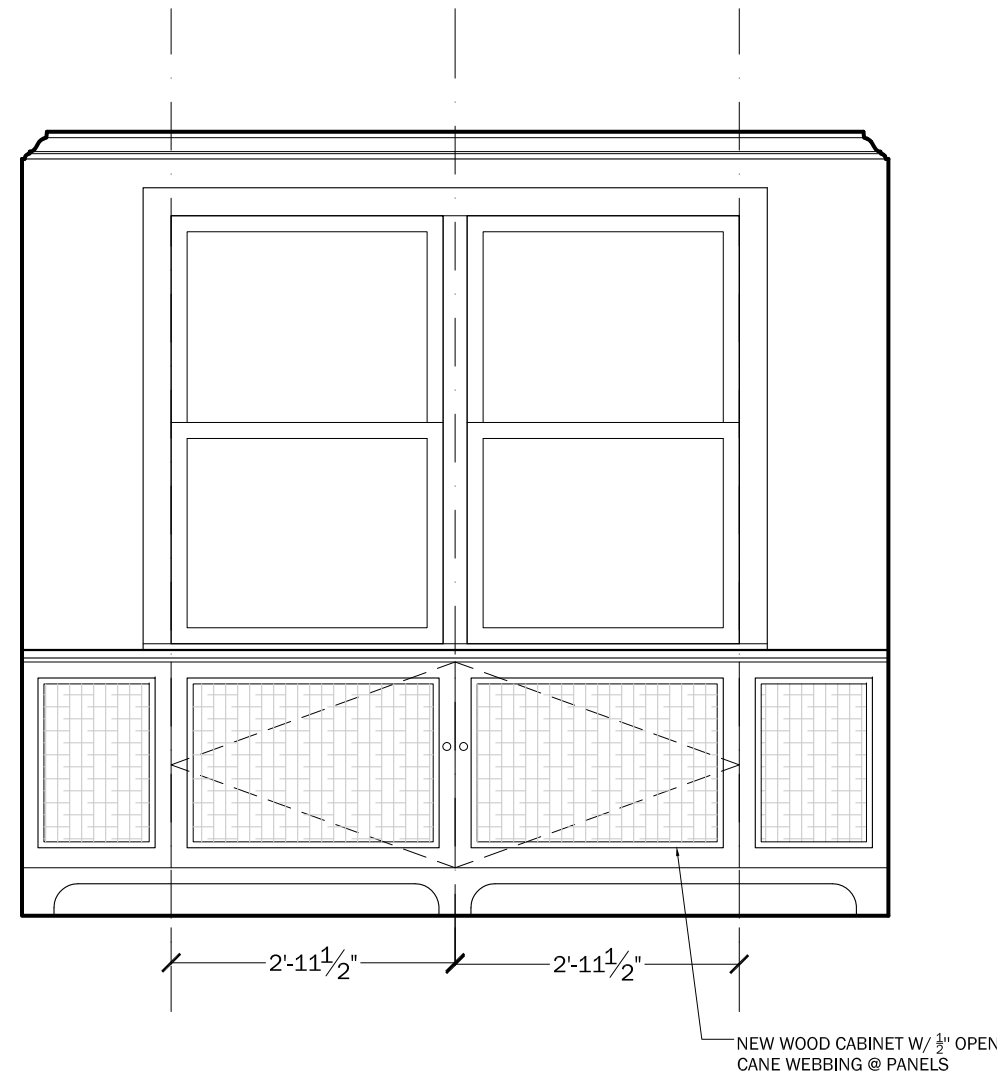

6 CHRIS'S BR - SOUTH  
 $\frac{1}{2}'' = 1'-0''$

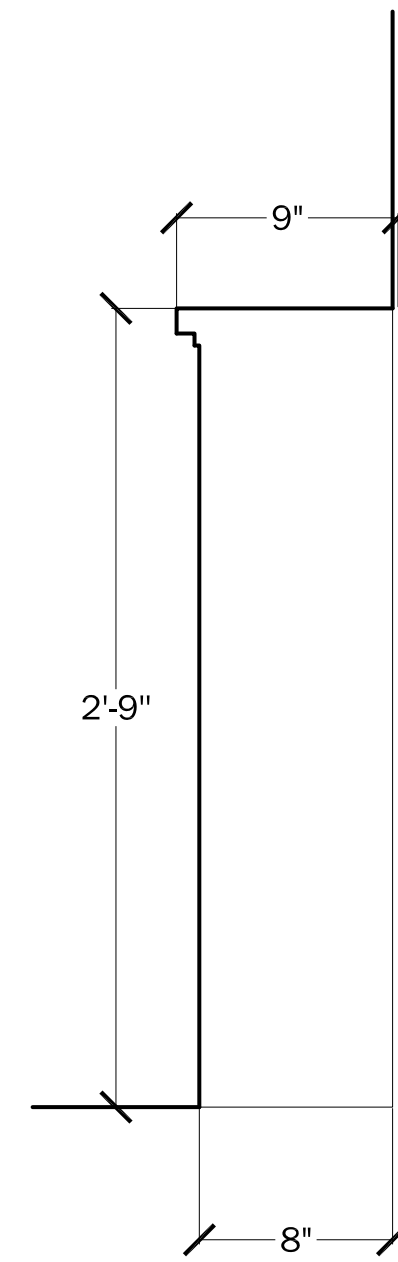

7 SECTION @ COVER  
 $1 \frac{1}{2}'' = 1'-0''$

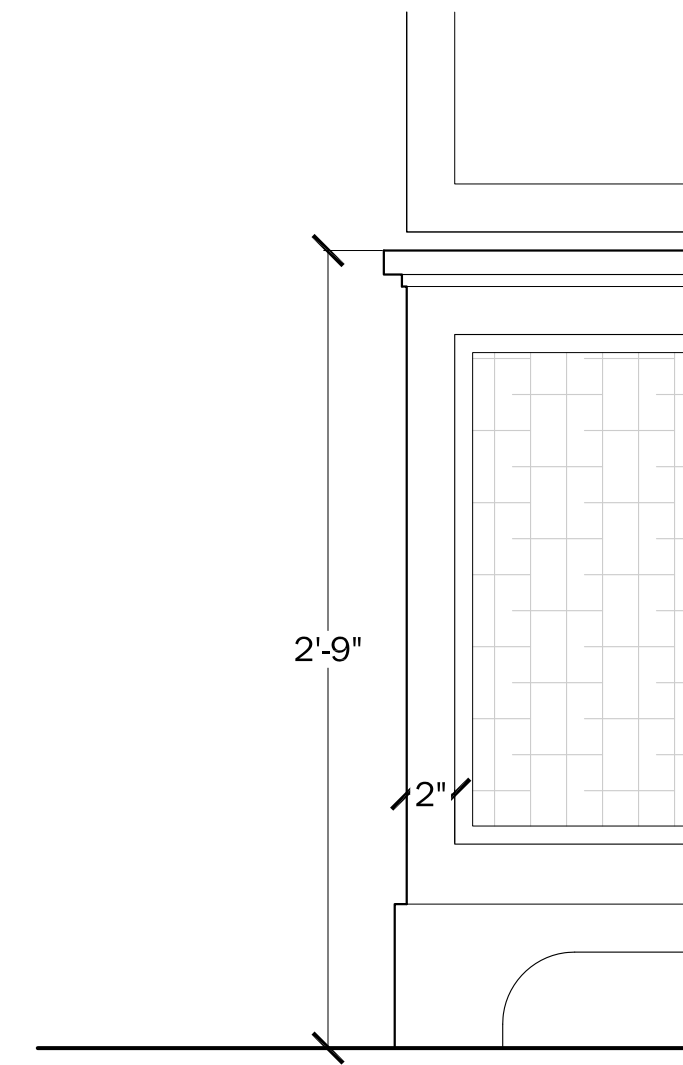

8 DETAIL @ COVER  
 $1 \frac{1}{2}'' = 1'-0''$

<b>ANGELL RESIDENCE</b>		<b>KENYON C. BOLTON III &amp; ASSOCIATES</b> 100 GARDEN STREET, CAMBRIDGE, MA 617.547.4440	
DESCRIPTION	DATE	DRAWING TITLE	
ESTIMATING DOCUMENTS	03.27.2017	<b>INTERIOR ELEVATIONS &amp; DETAILS</b>	
<b>A-5</b>			